

# **FORTEVER®**

## **零 件 书**

### **SPARE PARTS BOOK**

**HOUSEHOLD EMBROIDERY MACHINE**

**家用小型电脑绣花机**

# HOUSEHOLD EMBROIDERY MACHINE

## 家用小型电脑绣花机

### C O N T E N T S

### 目 录

1	Rotary Hook Base 梭床	8	Thread Stand 线架
2	Machine Base 底座	9	Machine Cover 机器罩盖
3	Arm 机头臂	10	Color Change Parts 换色
4	X Axis Guide Rail X向导轨	11	Thread Tension Base 夹线器
5	Y Axis Guide Rail Y向导轨	12	Stand (Select Accessories) 底架 (选配件)
6-1	Jump Motor Upper Thread Hook 机头跳跃 勾线 面夹	13	Embroidery Frame 花架
6-2	Needle Bar Driving Cam Set 针杆驱动、挑线驱动	14	Cap Stand Frame (Select Accessories) 帽框组件 (选配件)
7-1	Needle bar Take Up Lever 针杆架	15	Cap Frame Parts (Select Accessories) 帽座 (选配件)
7-2	Head Cover Thread Lock 面盖 下过线		

# 1 Rotary Hook Base 梭床

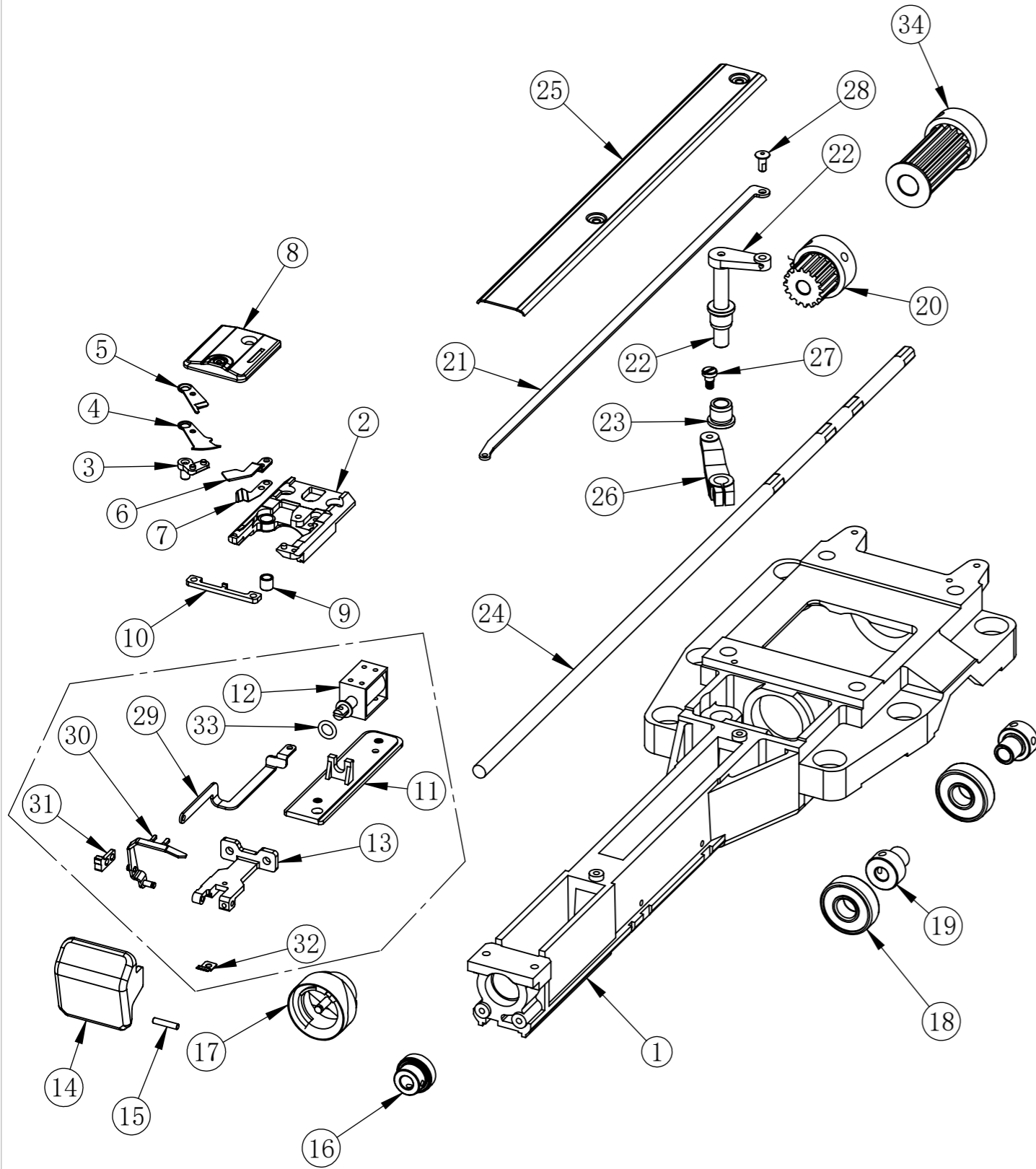

# 1 Rotary Hook Base 梭床

No.	Chinese Description	Description	Part No.	Qty
1	梭床 - 家用机	Rotary Hook Base	0110030001	1
2	针板座 - 家用机	Needle Plate Base	0110030002	1
3	动刀轴座 - 家用机	Movable Knife Drive Arm Clipper	0110030003	1
4	动刀 (下) - 家用机	Moveable Knife Do	0110030004	1
5	动刀 (上) - 家用机	Moveable Knife Up	0110030005	1
6	定刀 - 家用机	Fixed Knife	0110030006	1
7	定刀弹片 - 家用机	Fixed Knife Shrapnel	0110030007	1
8	针板 - 家用机	Needle Plate	0110030008	1
9	铜套 - 动刀轴	Copper Bush	0110030009	1
10	旋梭定位勾 - 家用机	Rotary Position Hook	0110030010	1
11	扣线电磁铁底板 - 家用机	Picker Solenoid Base	0110030011	1
12	扣线电磁铁 - 家用机	Picker Solenoid		1
13	扣线叉底板 - 家用机	Fork Base	0110030012	1
14	旋梭护盖 - 家用机	Cover	0110030013	1
15	护罩销D3	Pin D3	0110030014	1
16	联体轴承D21d7点94	Bearing		1
17	旋梭	Hook		1
18	轴承6201	Bearing		2
19	旋梭轴后轴套	Baffle	0105030017	2
20	组合同步轮 S5M 16T32T W18	Timing Pulley	0110030015	1
21	剪线薄拉杆 - 家用机	Trimming Pull Rod	0110030016	1
22	剪线驱动臂 - 家用机	Thread Trimming Lever	0110030017	1
23	铜套D12-d8	Oiled Bearing	0103030012	2
24	旋梭轴 -家用机	Rotary Hook Shaft	0110030018	1
25	梭床中盖板 - 家用机	Cover	0110030019	1
26	d8开口剪线连杆 - 锁紧反向	Drive Arm	0110030020	1
27	剪线螺丝	Screw Pin	0105070008	1
28	剪线拉杆销	Pin	0106040013	1
29	扣线电磁铁连杆 - 家用机	Picker Solenoid	0110030021	1
30	扣线叉 - 家用机	Picker Fork	0110030022	1
31	扣线限位块 - 家用机	Picker Fork Limit Block	0110030023	1
32	护罩弹片	Shield Shell	0110030024	1
33	O形橡胶圈	Rubber	0110030025	1
34	同步轮 S5M 16T W47	Timing Pulley	0110030026	1

## 2 Machine Base 底座

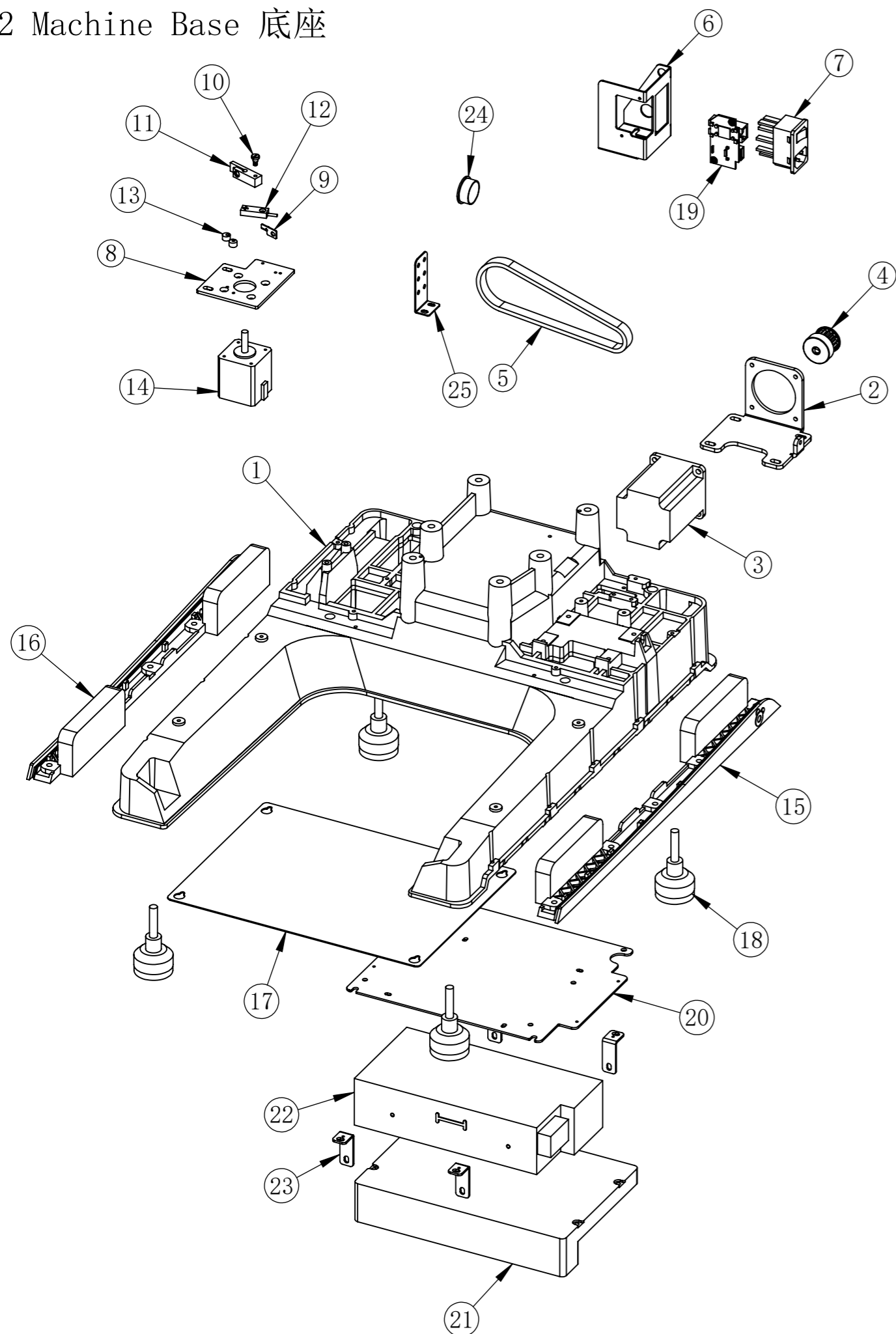

## 2 Machine Base 底座

No.	Chinese Description	Description	Part No.	Qty
1	底座 - 家用机	Machine Base	0110110001	1
2	60电机安装座	Motor Base	0110110002	1
3	钣金马头主电机 60SF3A50-355-1000Z	Motor		1
4	同步轮 S5M16TW13d8	Timing Pulley	0110110003	1
5	同步带 S5M L390 W12	Timing Belt		1
6	电源开关接口板	On/off Board		1
7	三合一电源开关插座 - 卡式品字	Mains Switch	0110110004	1
8	家用机42剪线电机安装板	Motor Base	0110110005	1
9	剪线感应片	Sensor Plate	0105070005	1
10	剪线螺丝	Screw Pin	0105070008	1
11	剪线驱动块	Trimming Drive Rod	0105070004	1
12	接近感应器 SP08-D3NA - 大	LIMIT SENSOR	0105070001	1
13	橡胶缓冲套	DAMPER RING	0102090013	2
14	42电机 42H47	Step Motor	0206015015	1
15	长扶条 - 右	Rubber Handle R	0110260001	1
16	长扶条 - 左	Rubber Handle L	0110260002	1
17	底盆电子板下盖板	Under Cover	0110260003	1
18	底脚调节螺栓	Adjust Bolt	0110110006	4
19	网口USB板	USB Board		1
20	主控板底板 - 倒装通用	Board Plate	0110110007	1
21	瑞能主控盒外形	Main Control Box		1
22	A15-H家用单头机控制箱	Main Control Box		1
23	大豪主控盒L形支架	Bracket	0110110008	4
24	护线圈d25	Line Trap		1
25	走线角座	Cable Bracket	0110110009	1

### 3 机头臂 Arm

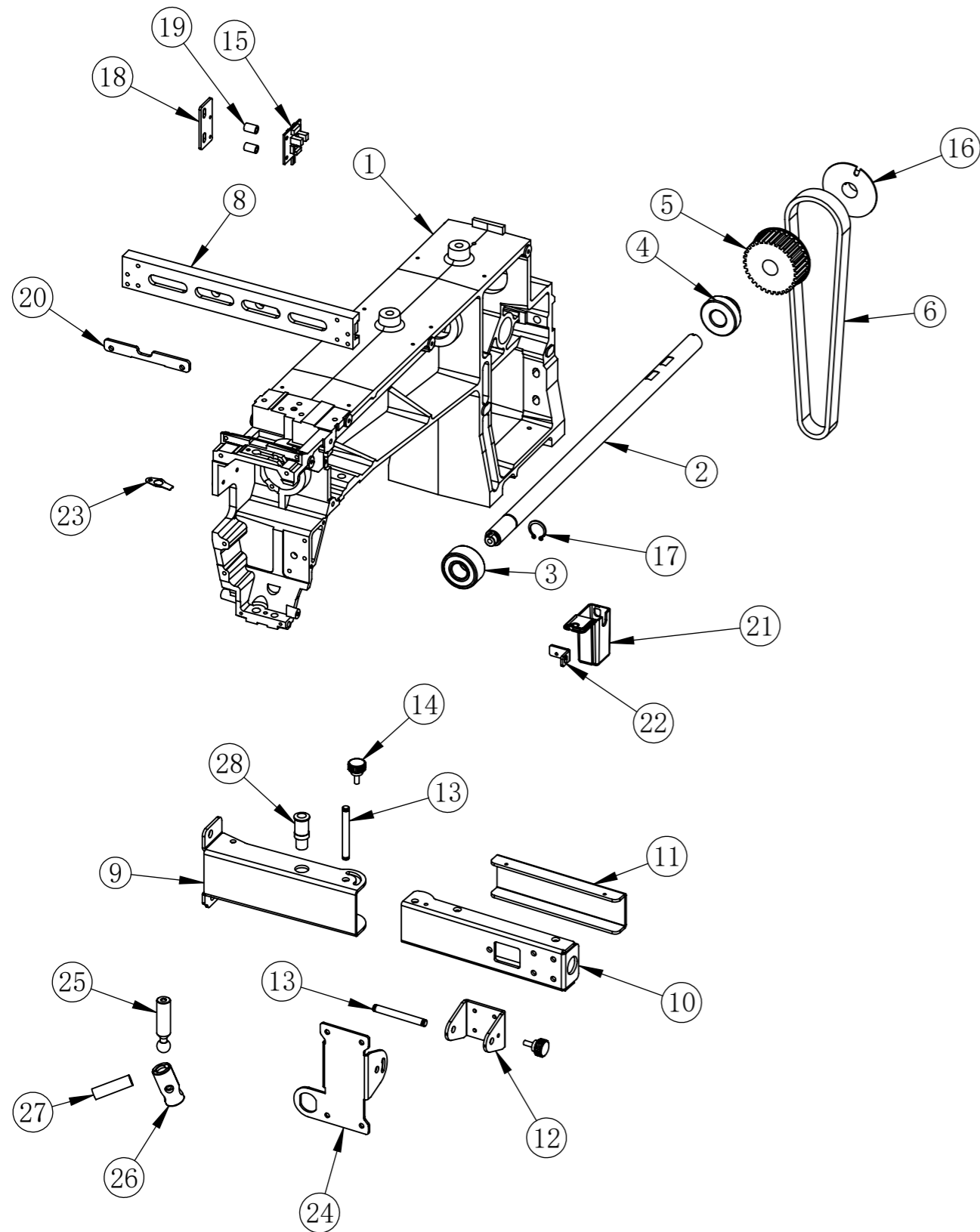

### 3 机头臂 Arm

No.	Chinese Description	Description	Part No.	Qty
1	机头臂 - 放斜度	Arm	0110100001	1
2	家用机上轴 - 压簧挑线	Upper Shaft	0110010002	1
3	双列轴承3202 D35d15H16	Bearing	0202010035	1
4	联体轴承6003	Bearing		1
5	马头上轴同步轮 S5M 32T W20	Timing Pulley	0110010003	1
6	马头上下轴同步带 S5M L525 W15	Timing Belt		1
7	12针嵌装直线导轨下板	Guide Rail	0110010018	1
8	12针嵌装直线导轨上板			1
9	显示器支架A段 - 家用机	Stand A	0110010004	1
10	显示器支架B段 - 家用机	Stand B	0110010005	1
11	显示器支架C段 - 家用机	Stand C	0110010006	1
12	显示器后座B	Back Bracket	0110010007	1
13	转轴销D6	Pin D6	0110010008	2
14	梅花螺栓M4	Bolt M4	0110010009	2
15	主轴零位感应板	ZERO Board		1
16	主轴零位感应轮-d15	ZERO POSITION DISK	0110010017	1
17	卡簧d15	Snap Spring		1
18	零位光耦安装板	Plate	0110010010	1
19	绝缘柱d4D7H11	Washer	0110010011	2
20	针架换色导板 - 家用机 - 短	Guide Plate	0110010012	1
21	机头上油杯	Oil Cup	0110010013	1
22	机头油杯支架	Support	0110010014	1
23	机头油管压片	Press Slice	0110010016	1
24	后支架体	Back Bracket B	0110010017	2
25	旋转柱头 - 家用机用	Infrared Location Bracket	0106010022	1
26	塑料立柱	Infrared Location Bracket	0106010022	1
27	红外线定位器	Infrared Location	0207270001	1
28	d12按钮开关	Switch		1

#### 4 X Axis Guide Rail X向导轨

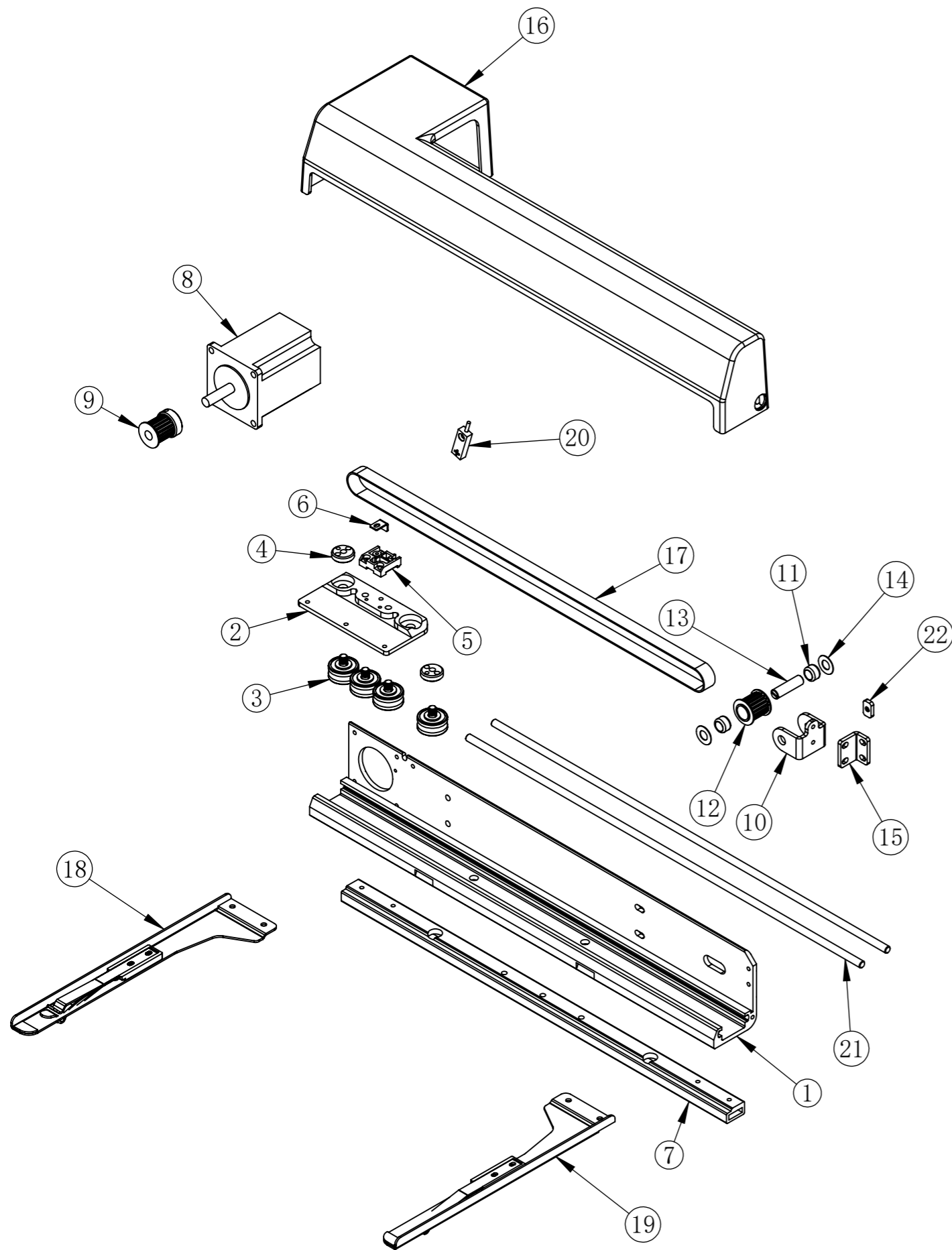

#### 4 X Axis Guide Rail X向导轨

No.	Chinese Description	Description	Part No.	Qty
1	家用机X框架底板	X-Rail Base	0110150001	1
2	X框架轴承安装板	Bearing Slide Block	0110150002	1
3	U型槽轴承D24H11M6	U Bearing SG66	202010013	4
4	调节偏心螺母M6	Eccentric Nut	0110150003	2
5	X皮带压块 - 塑料	Belt Press Block	0110150004	1
6	遮光感应片	Sensor Slice	0110150005	1
7	扶手基板 X320	Hold Hand Base	0110150006	1
8	57H3P064-5806AZ08步进电机	Step Motor	0206010006	1
9	X主动轮	Timing Pulley	0105150036	1
10	X被动轮座 - 家用机	Pulley Base	0110150007	1
11	轴承HK0808	Bearing		2
12	X被动轮	Pulley	0108200008	1
13	X被动轮轴 - 家用机	Timing Pulley Shaft	0110150008	1
14	四氟乙烯垫片d8	Washer	0110150009	2
15	被动轮调节支架	Bracket	0110150010	1
16	X驱动塑料主罩盖	Cover	0110260004	1
17	X同步带	Timing Belt		1
18	家用机左边扶手板筋体 - Y240	Hold Hand L	0110200001	1
19	家用机右边扶手板筋体 - Y240	Hold Hand R	0110200002	1
20	接近感应器 SP08-D3NA - 大	LIMIT SENSOR	0105070001	1
21	X框架轴承导向轴 - 家用机	Guide Shaft	0110150011	2
22	X被动轮支架固定块	Block	0110150012	1

## 5 Y Axis Guide Rail Y向驱动

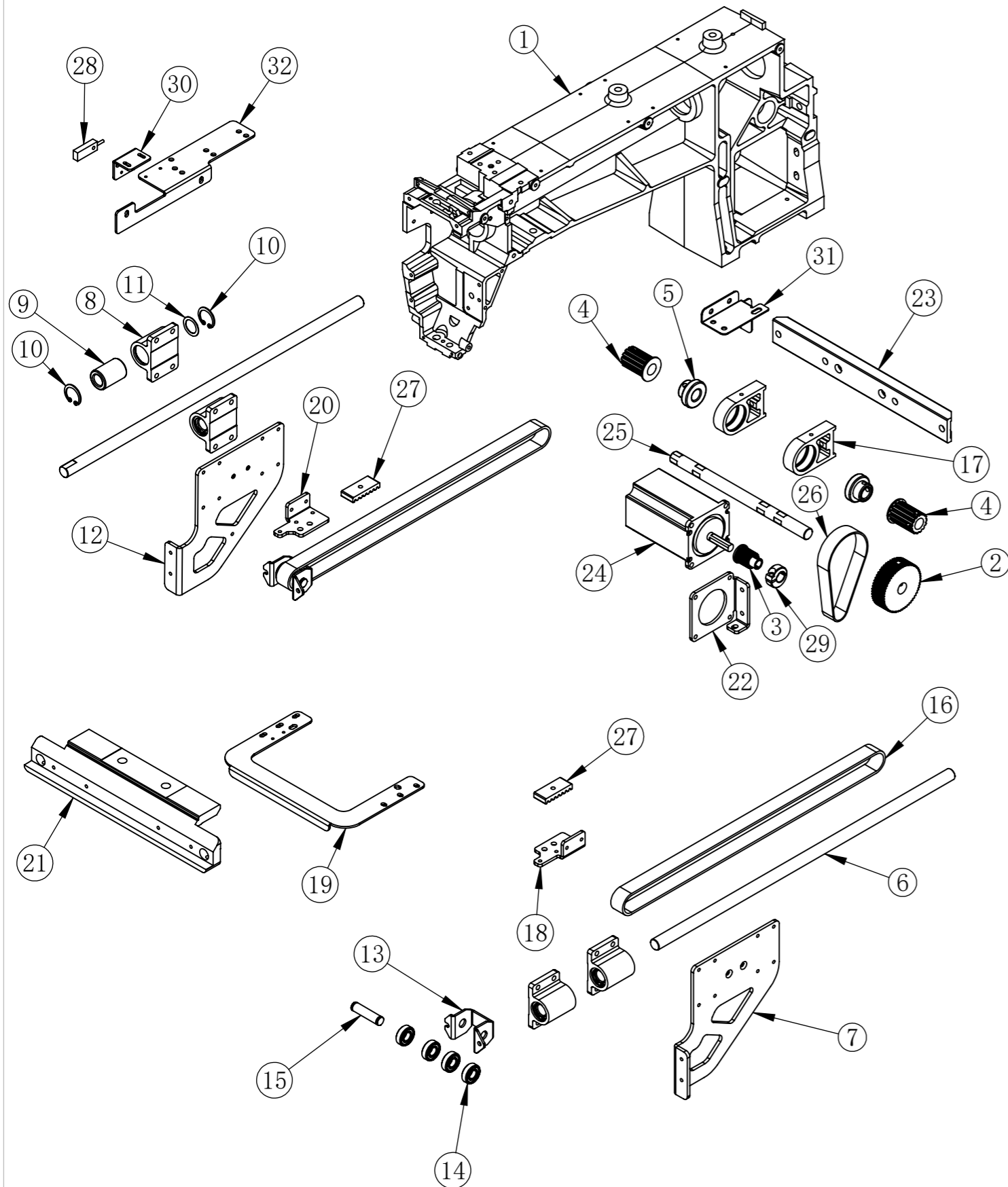

## 5 Y Axis Guide Rail Y向驱动

No.	Chinese Description	Description	Part No.	Qty
1	机头臂 - 放斜度	Arm	0110100001	1
2	Y电机大轮S3M54TW16 - d12	Timing Pulley	0110150021	1
3	Y电机轮S3M18TW16 - d8	Timing Pulley	0110150022	1
4	Y主动轮T5 14T d12	Timing Pulley	0110150023	2
5	联体轴承S6902RS d12	Bearing		2
6	Y导向轴 - 家用机	Y-Guide Shaft	0110150024	2
7	Y滑块支撑板 - 右	Support Plate R	0110150025	1
8	Y导向滑块壳体	Slider Block	0110150026	4
9	石墨铜套d12D21L30	Copper Cover	0110150027	4
10	21孔用卡环	Snap Ring		8
11	波形垫片D21d16T0.3	Washer		4
12	Y滑块支撑板 - 左	Support Plate L	0110150028	1
13	Y被动轮座 - 家用机	Pulley Base	0110150029	2
14	轴承699	Bearing		8
15	Y向被动轮轴-家用机	Pulley Shaft	0110150030	2
16	Y向皮带 T5 W16 - 家用机	Timing Belt		2
17	Y大轮轴承座	Bearing Base	0110150031	2
18	皮带压板支架 - 右	Bracket R	0110150032	1
19	左右支撑板联结板	Support Plate	0110150033	1
20	皮带压板支架 - 左	Bracket L	0110150034	1
21	驱动前支架板	Front Bracket Plate	0110150035	1
22	Y57电机座	Motor Base	0110150036	1
23	驱动后支架板 - 挤压铝	Back Bracket Plate	0110150037	1
24	57H3P086-4506AZ08-30	Motor		1
25	Y驱动轴-家用机	Y Drive Shaft	0110150038	1
26	同步带S3M-237-15	Belt		1
27	Y向皮带压板5MW16 - 家用机	PRESS BLOCK UP	0110150039	2
28	接近感应器 SP08-D3NA - 大	LIMIT SENSOR	0105070001	1
29	齿轮抱紧套-d11	Collar	0110150041	1
30	Y感应前置支架B	Y Sensor Base B	0110150042	1
31	走线槽板 - 一体	Cable Plate	0110150043	1
32	Y感应前置支架A	Y Sensor Base A	0110150044	1

6-1 机头跳跃 勾线 面夹 Jump Motor

6-1 机头跳跃 勾线 面夹 Jump Motor

No.	Chinese Description	Description	Part No.	Qty
1	机头臂 - 放斜度	Arm	0110100001	1
2	拨线叉左装 (小) - 家用	Thread Press Drive Set		1
3	马头勾线器装配体 - 家用机	Thread Hook Set		1
4	马头跳跃电机装配体 - 家用机	Arm Jumping Set		1

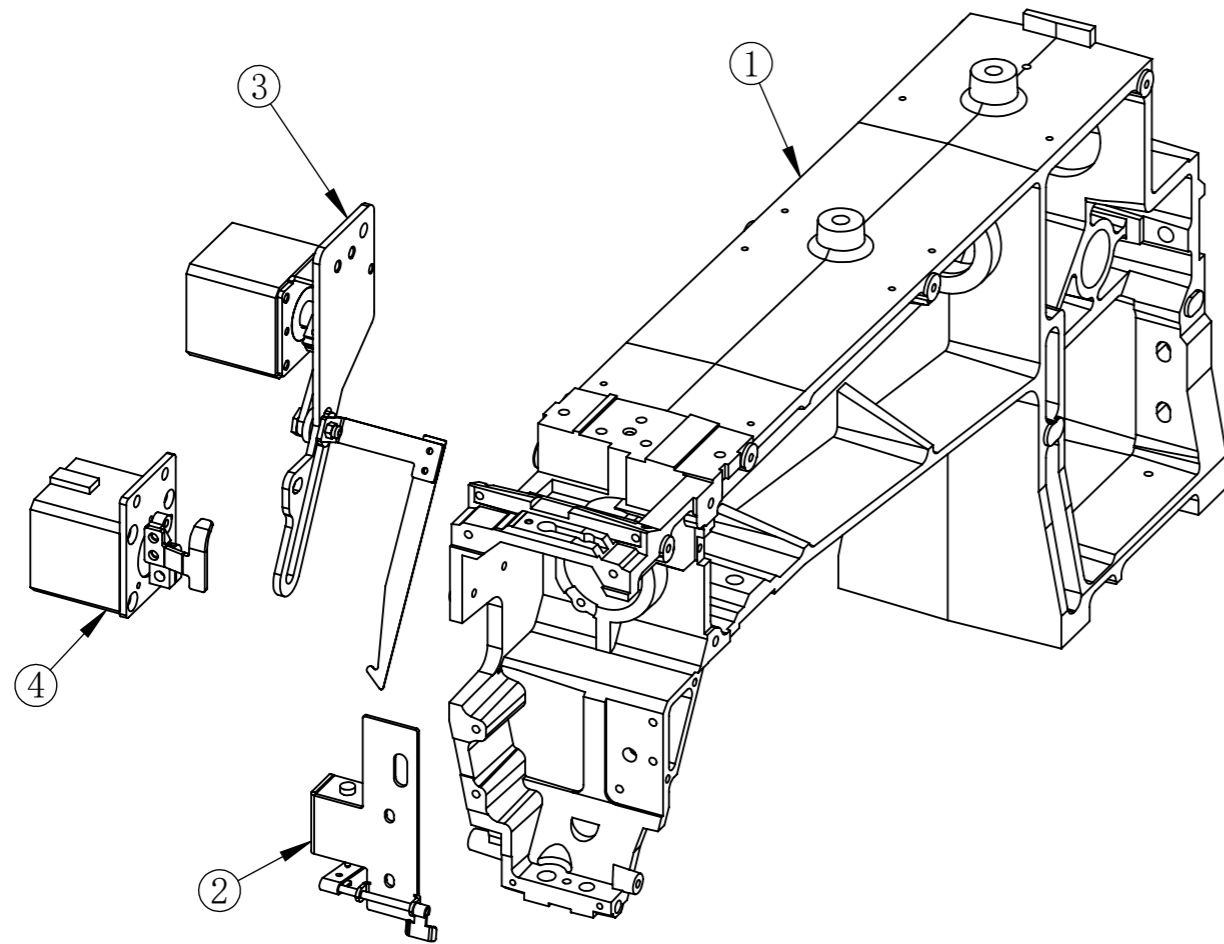



## 6-2 针杆驱动 挑线驱动 Needle Bar Driving Cam Set

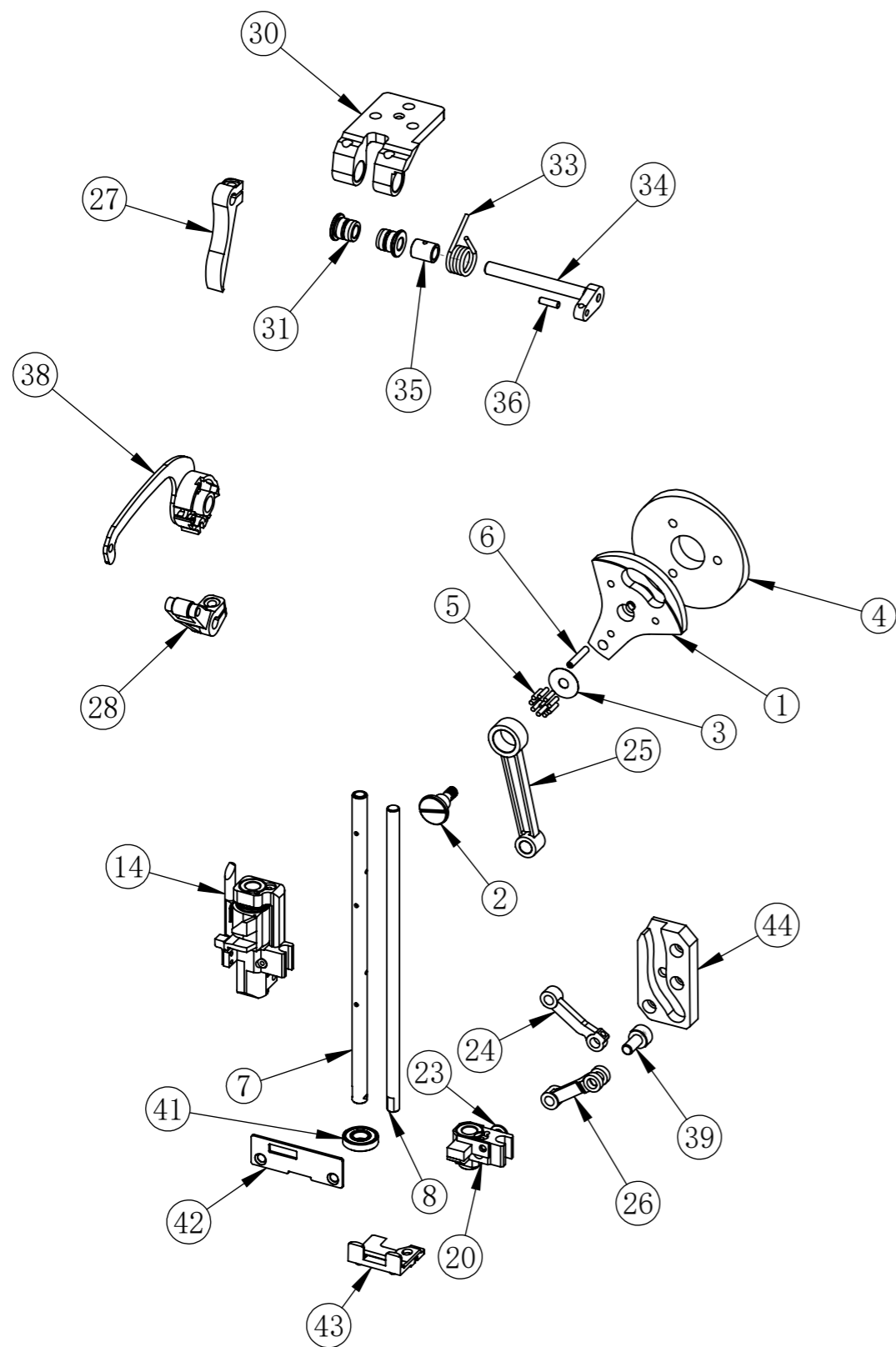

## 6-2 针杆驱动 挑线驱动 Needle Bar Driving Cam Set

No.	Chinese Description	Description	Part No.	Qty
1	针杆驱动半圆偏心块 -M式	Arm Cam	0110010018	1
2	连杆滚针轴承销 - M式	Bearing Pin	0110010019	2
3	薄垫片d5加大	Washing	0110010020	1
4	马头压簧挑线凸轮 优后	Take-Up Cam	0110010021	1
5	保持架滚针轴承 D12d8H7.8	Bearing	0110010043	1
6	齿形开口销D3	Pin	0110010022	1
7	针杆驱动轴	Drive Shaft	0104010009	1
8	压脚轴 - M式	Shaft	0110010023	1
14	驱动块 - 侧槽式	Needle Bar Reciprocator	0110010024	2
20	压脚驱动块本体 -侧槽式	Presser Foot Block	0110010025	1
23	压脚块挡边销d5	Pin	0110010026	1
24	侧槽压脚连杆 - 上	Connecting Rod Up	0110010027	1
25	马头机大连杆	Big Rod	0110010028	1
26	侧槽压脚连杆 - 下	Connecting Rod Do	0110010029	1
27	压簧挑线弧槽驱动臂	Drive Rod	0110010030	1
28	马头压簧挑线杆B	Spring Trestle Rod	0110010031	1
30	挑线臂支点座	Take-up Bar Base	0110010032	1
31	支点轴铜套A	Copper	0110010033	1
33	挑线扭簧	Spring	0110010034	1
34	马头压簧支点轴臂	Thread Trimming Lever	0110010035	1
35	压簧套圈	Spring Collar	0110010036	1
36	销D3	Pin	0110010037	1
38	挑线杆片	TAKE-UP LEVER	0110010038	1
39	带销轴承D10d5	Bearing	0110010039	1
41	轴承D17d7点24	Bearing	0202010004	1
42	针杆箱下导板	GUIDE PLATENEEDLE BAR CASE	0110010041	1
43	马头机下导轨定位勾	Positioning Hook	0110010042	1
44	机头压脚弧槽	PressFoot Cam	0110010040	1

7-1 Needle Bar Take Up Lever 针杆架

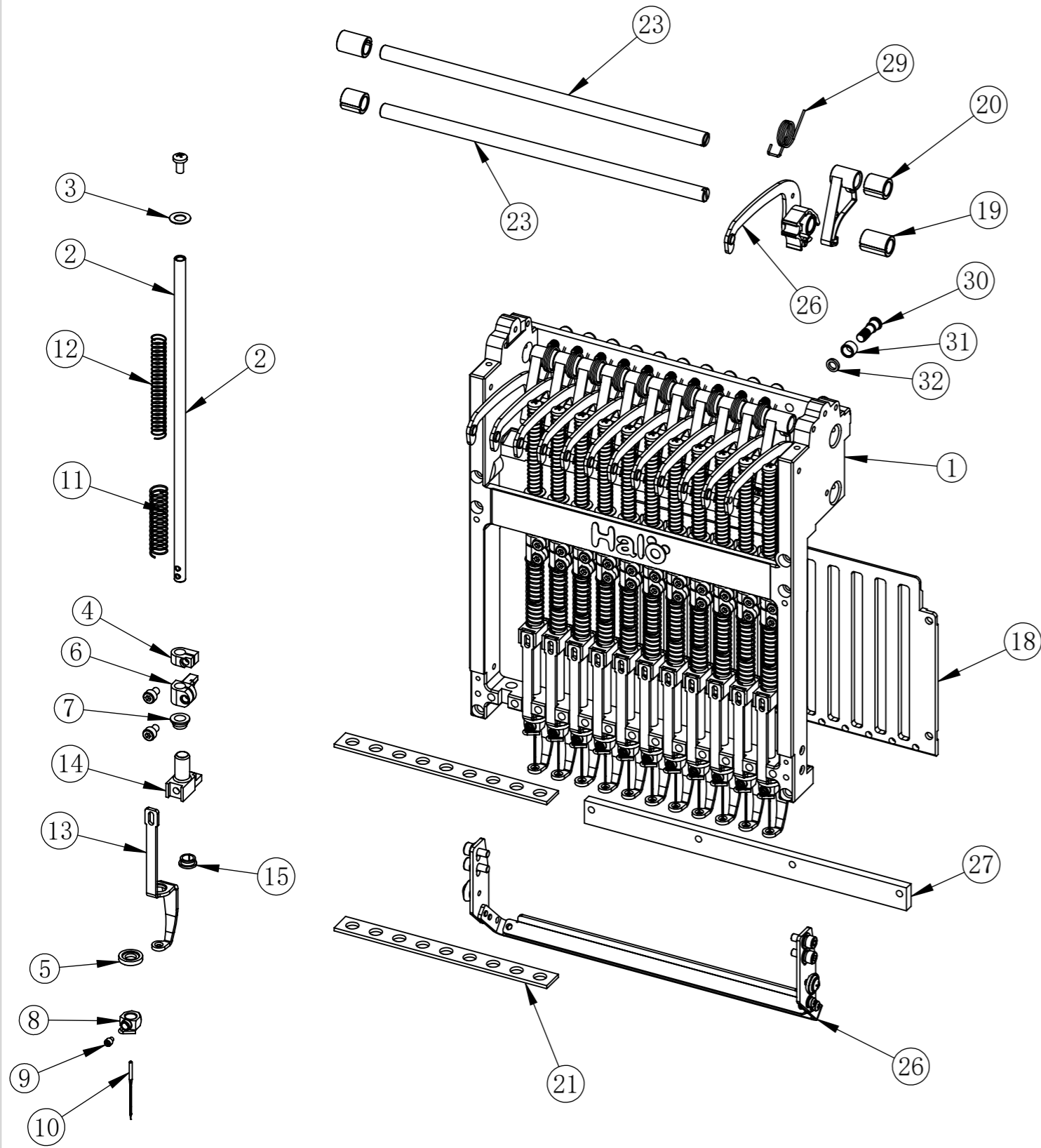

7-1 Needle Bar Take Up Lever 针杆架

No.	Chinese Description	Description	Part No.	Qty
1	针杆架 自扣式	Needle Case		1
2	针杆	Needle Bar	0102020004	12
3	上弹簧垫片	Washer		12
4	上死点固定块件	Stopper Upper Poin	0102020008	12
5	O形橡胶圈	Washer	0102020057	12
6	针杆连接销	Connecting Pin	0102020009	12
7	针杆下弹簧套圈	Spring Collar		12
8	针夹 (连螺钉)	Needle Clamp	0102020016	12
9	针夹螺钉	Screw		12
10	针	Needle		12
11	针杆下弹簧	Compression Sprin	0102020011	12
12	针杆上弹簧	Upper Spring	0102020005	12
13	压脚 56	Presser Foot	0102020014	12
14	压脚调节套	Presser Foot Set Clamp	0102020013	24
15	压脚开口轴衬	Presser Foot Bushing	0102020012	12
16	压脚调节套	Presser Foot Set Clamp	0102020013	12
17	自扣	Lever Stopper	0102020032	13
18	12针反转挡板	Baffle	0102020025	1
19	针架开口轴衬L16点5	Split Collar	0102020022	2
20	针架开口轴衬L12点5	Split Collar	0102020017	2
21	下毛毡垫 9N	Felt Packing	0102020015	2
22	麻垫	Damper Ring	0102020007	1
23	挑线杆导向轴 9N	Guide Shaft	0102020018	2
24	挑线齿轮-压簧凸轮	Boss	0102020021	1
25	挑线杆片	Take-up Lever	0110010038	1
26	下毛刷	Thread Holder		1
27	下导轨	Lower Guide Rail	0102020042	1
28	挑线杆片	Take-up Lever	0102020019	12
29	自扣弹簧 - 马头	Spring		12
30	分段销	Pin	0106010014	12
31	换色滚珠	Collar	0106010013	12
32	垫片	Bushing	0106010015	12

7-2 Head Cover Thread Lock 面盖、中下过线

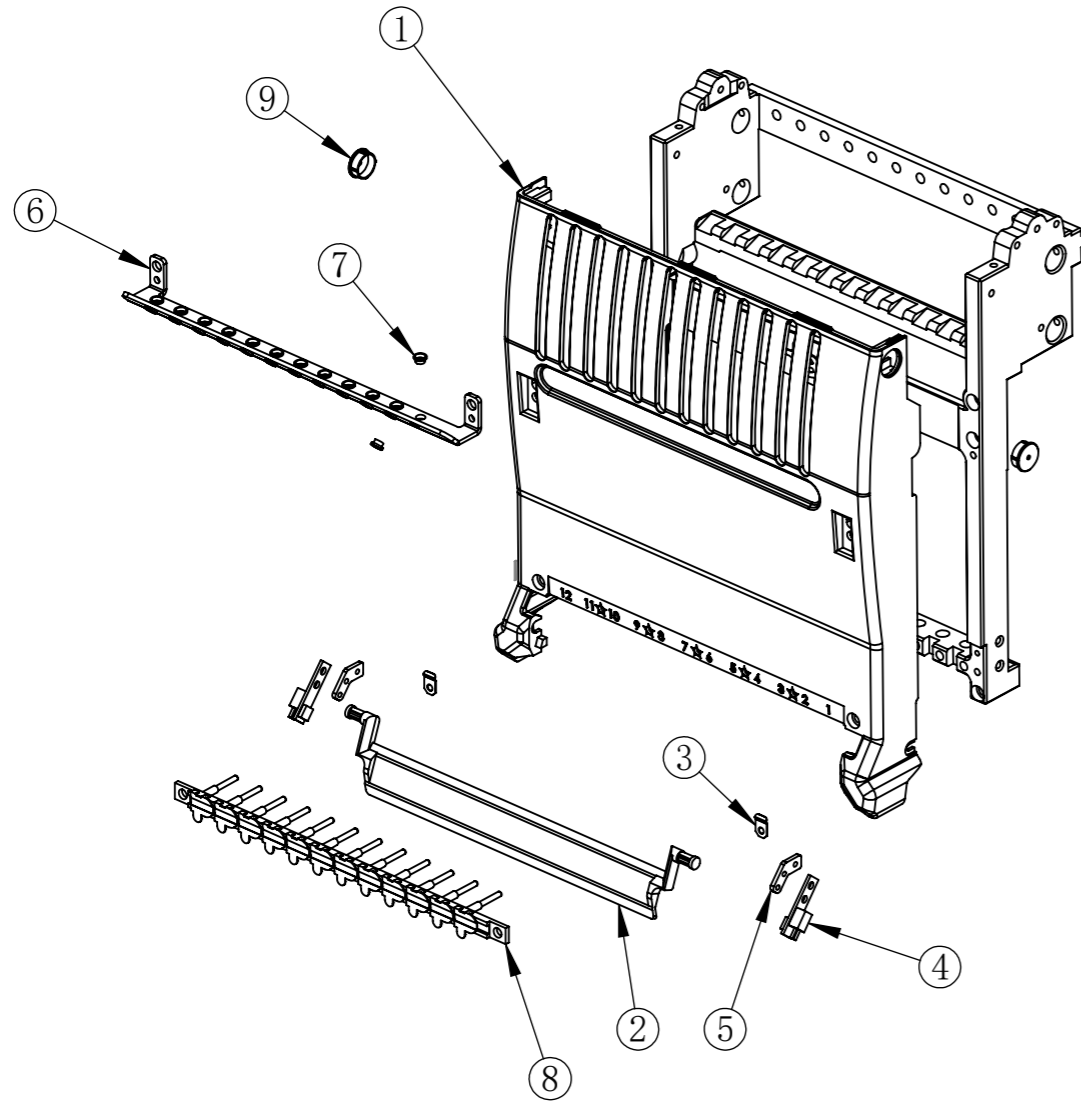

7-2 Head Cover Thread Lock 面盖、中下过线

No.	Chinese Description	Description	Part No	Qty
1	主面盖-12针 家用机	Protect Cover	0110010051	1
2	针透明保护板 - 12针	Protect Plate	0110010052	1
3	保护板弹片	Plate Shrapnel	0110010053	2
4	LED侧灯	LED		2
5	Led灯底板	Led Base	0110010054	2
6	整面板中过线 -12针	Middle Thread Course Shaft	0110010055	1
7	瓷眼D4. 3d2. 4H3	Porcelain Sleeve		24
8	下面线压线架 - 12针	Thread Press Set	0110010056	1
9	螺丝盖头	Screw Cover	0110260017	2

# 8 Thread Stand 线架

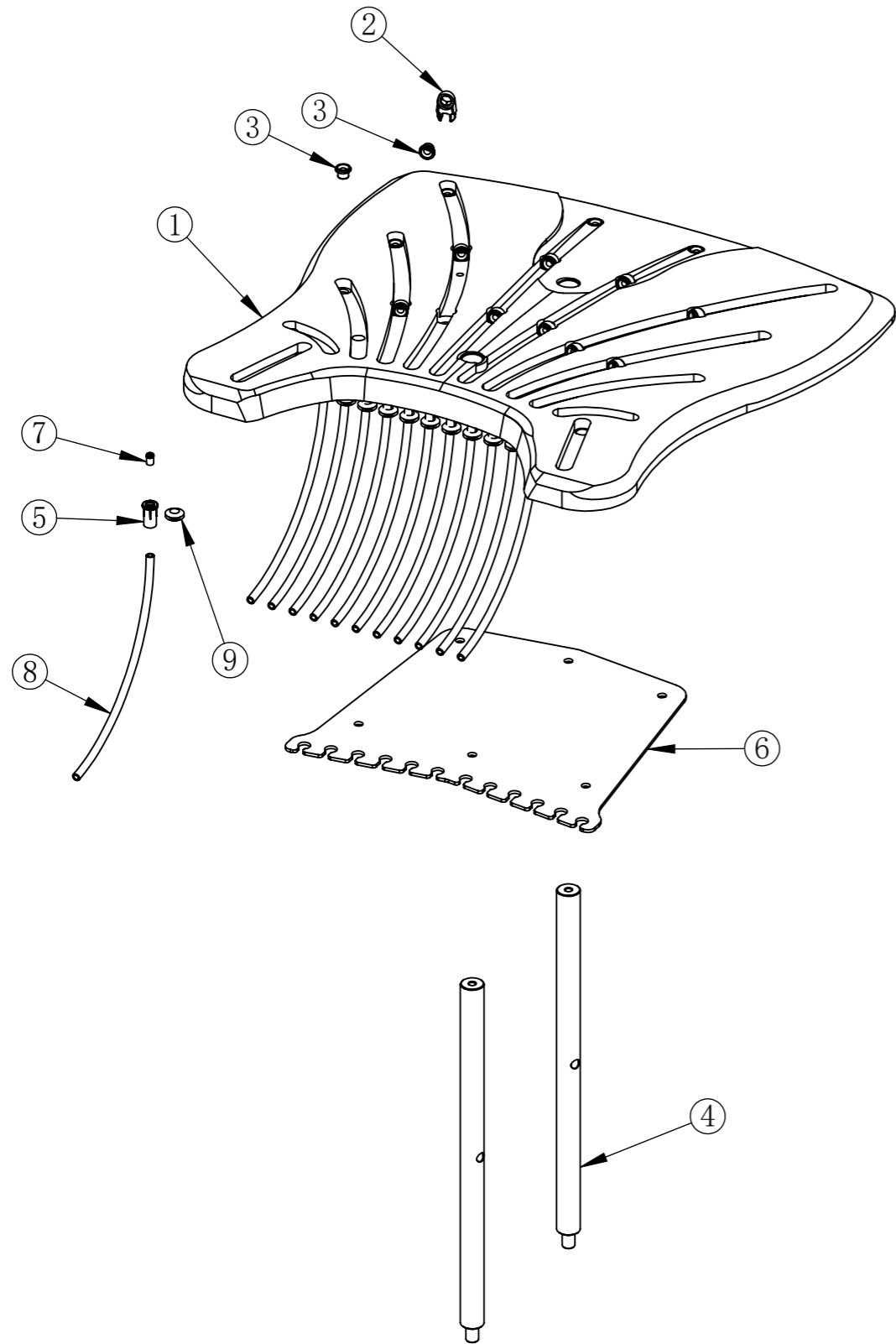

# 8 Thread Stand 线架

NO.	Chinese Description	Description	Part No.	Qty
1	家用机线架板 - 12针 - 前凹	Wire Feame Plate	0110210001	1
2	线架瓷眼座	Porphyry Eye Base	0110210002	10
3	线架瓷眼D6点8	Porphyry Eye		22
4	线架立柱	Thread Stand	0110210003	2
5	导线管套头 - 线架端	Plastica Collar	0110210004	12
6	线盘加强板	Thread Stand Plate	0110210005	1
7	套头内瓷套	Porcelain Sleeve	0110210006	12
8	透明线管	Line Pipe	0110210007	12
9	双面护线橡胶圈d6	Rubber Ring	0110210008	12

# 9 Machine Cover 机器罩盖

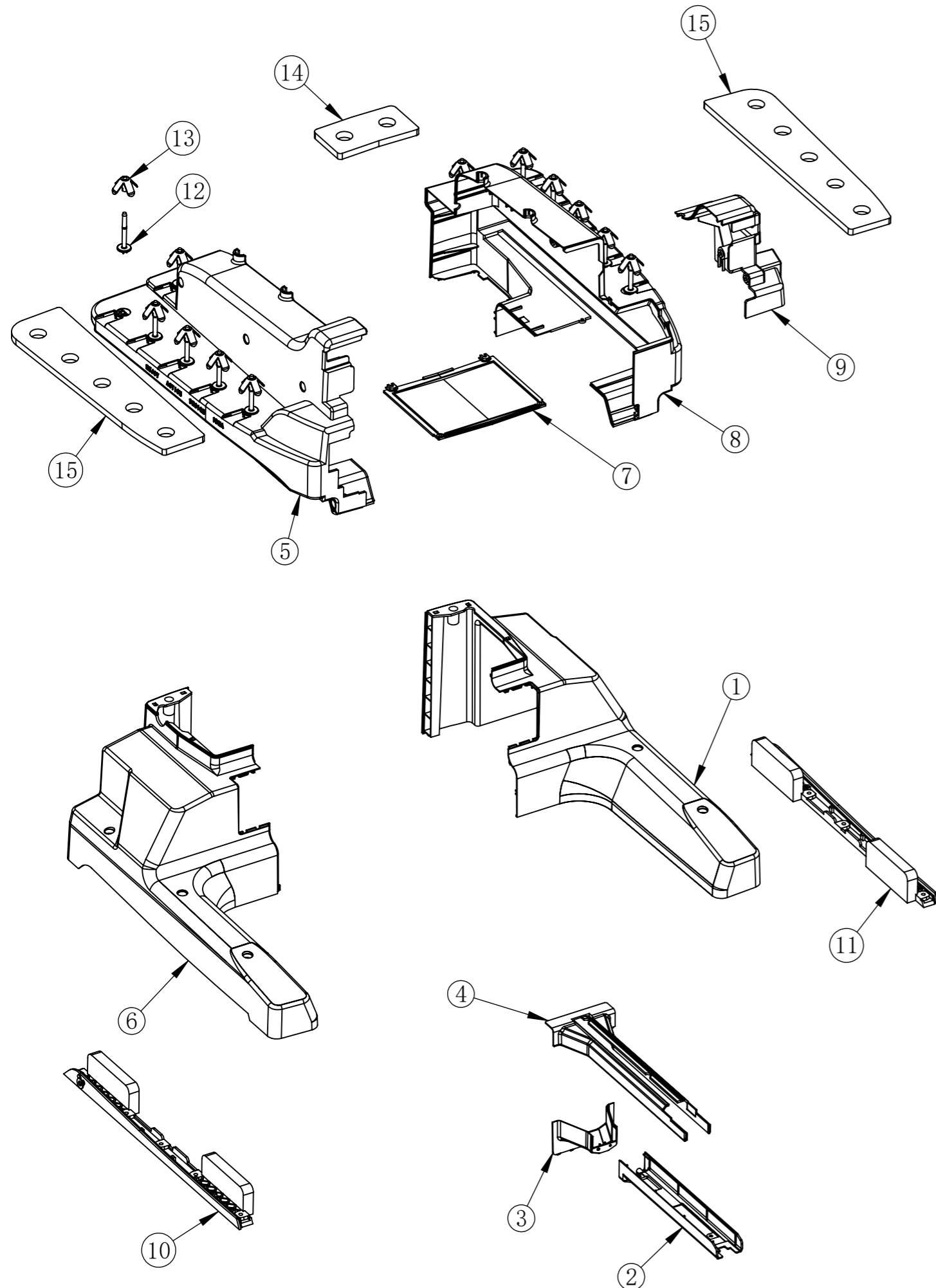

# 9 Machine Cover 机器罩盖

No.	Chinese Description	Description	Part No.	Qty
1	底座罩盖 - 右 - 扶条	Base Cover R	0110260005	1
2	梭床下罩盖 - 前段	Hook Base Cover Front	0110260006	1
3	梭床下罩盖 - 后段	Hook Base Cover Back	0110260007	1
4	梭床上罩盖	Hook Base Cover Upper	0110260008	1
5	机头罩盖 - 左 - 12针 - 外凹	Arm Cover L	0110260009	1
6	底座罩盖 - 左 - 扶条	Base Cover L	0110260010	1
7	机头罩盖 - 中前下	Arm Cover Mid	0110260011	1
8	机头罩盖 - 右 - 12针 - 外凹	Arm Cover R	0110260012	1
9	机头罩盖 - 右 - 12针 - 外凹 - 前小块	Arm Cover R Small	0110260013	1
10	长扶条 - 左	Rubber Handle L	0110260002	1
11	长扶条 - 右	Rubber Handle R	0110260001	1
12	线团钉 - 家用机	Pin	0110210011	12
13	线团伞 - 家用机	Umbrella	0110210012	12
14	线团软垫 - 后	Back Cushioning	0110210010	1
15	线团软垫	Cushioning	0110210009	2

## 10 Color Change Parts 换色

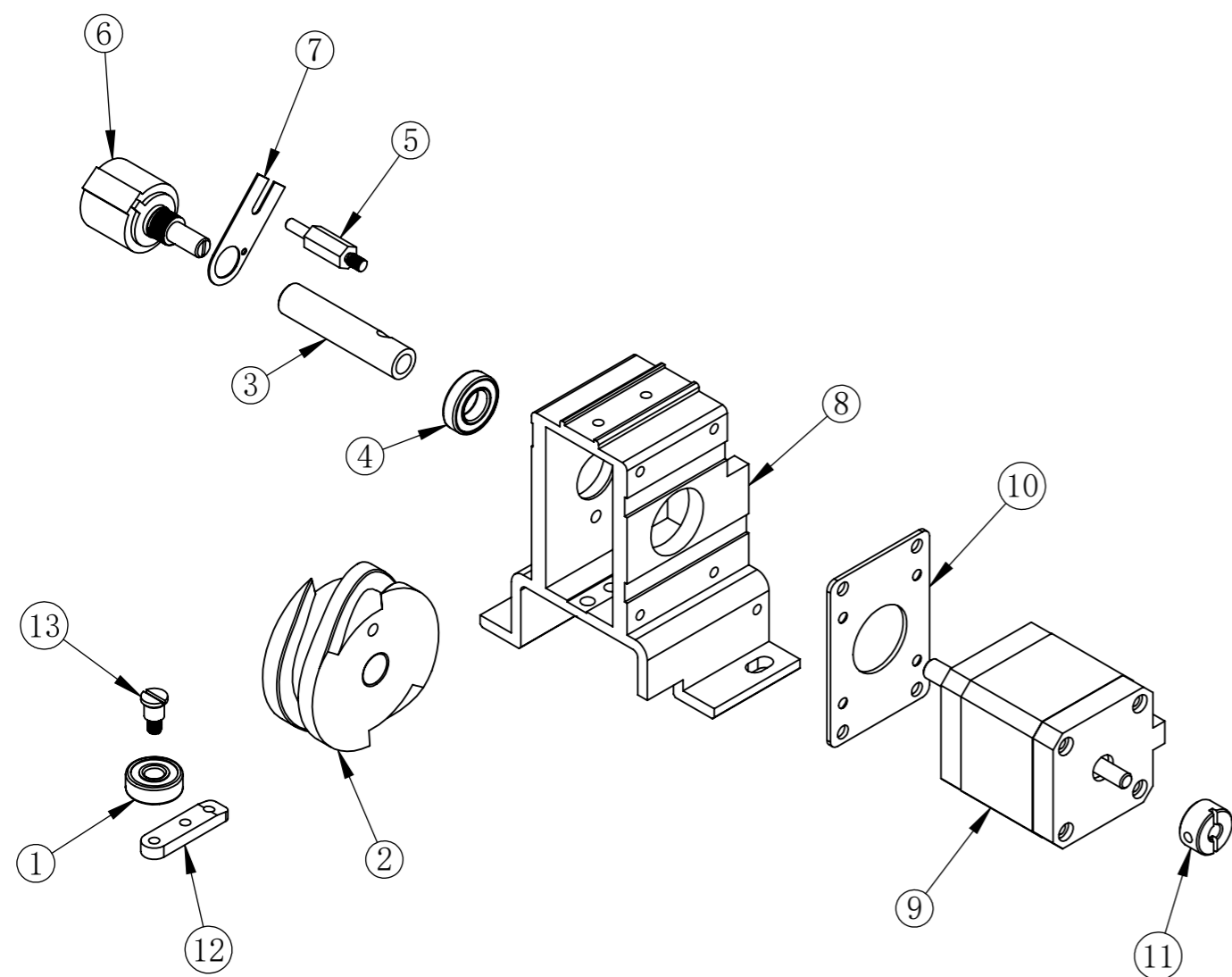

## 10 Color Change Parts 换色

No.	Chinese Description	Description	Part No.	Qty
1	轴承606z	Bearing	0202010012	1
2	换色 凸轮	Cam	0106010002	1
3	电位器铜套	Bushing	0106010018	1
4	轴承6800z	Bearing	0202010011	1
5	电位器螺栓	Fixed Bolt	0106010005	1
6	电位器	Potentiometer	0207020001	1
7	电位器支撑板	Potentiometer Support	0106010020	1
8	换色底座 - 铝型材	Color Change Base	0110010061	1
9	电机 42H47	Motor	0206015015	1
10	42换色电机板	Motor Plate	0110010063	1
11	电机旋钮 - 家用机	Handle	0110010064	1
12	自扣轴承板	Bearing Plate	0110010065	1
13	换色轴承台阶销d6L12	Pin	0106010006	1

# 11 Thread Tension Base 夹线器

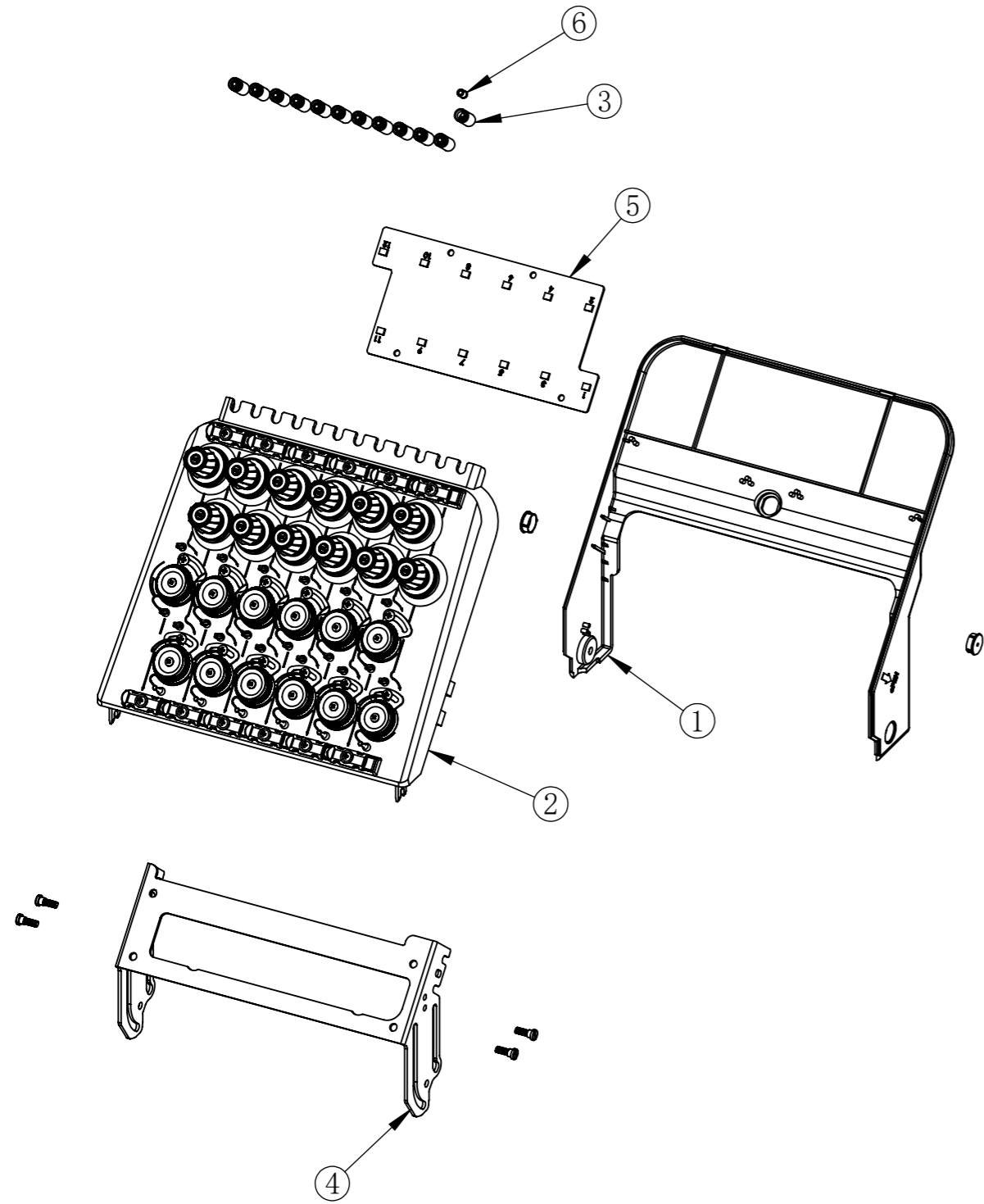

# 11 Thread Tension Base 夹线器

No.	Chinese Description	Description	Part No.	Qty
1	家用机夹线器 - 下板	Thread lead Plate	0110060001	1
2	家用机夹线器 - 上板	Thread lead Plate	0110060001	1
3	导线管套头 - 夹线器端	Collar	0110060002	12
4	夹线器前板支架	Support	0110060003	1
5	磁感应板 - 12针	PCB	0110060004	1
6	套头内瓷套	Porcelain Sleeve	0110210006	12

## 12 Stand 家用机底架

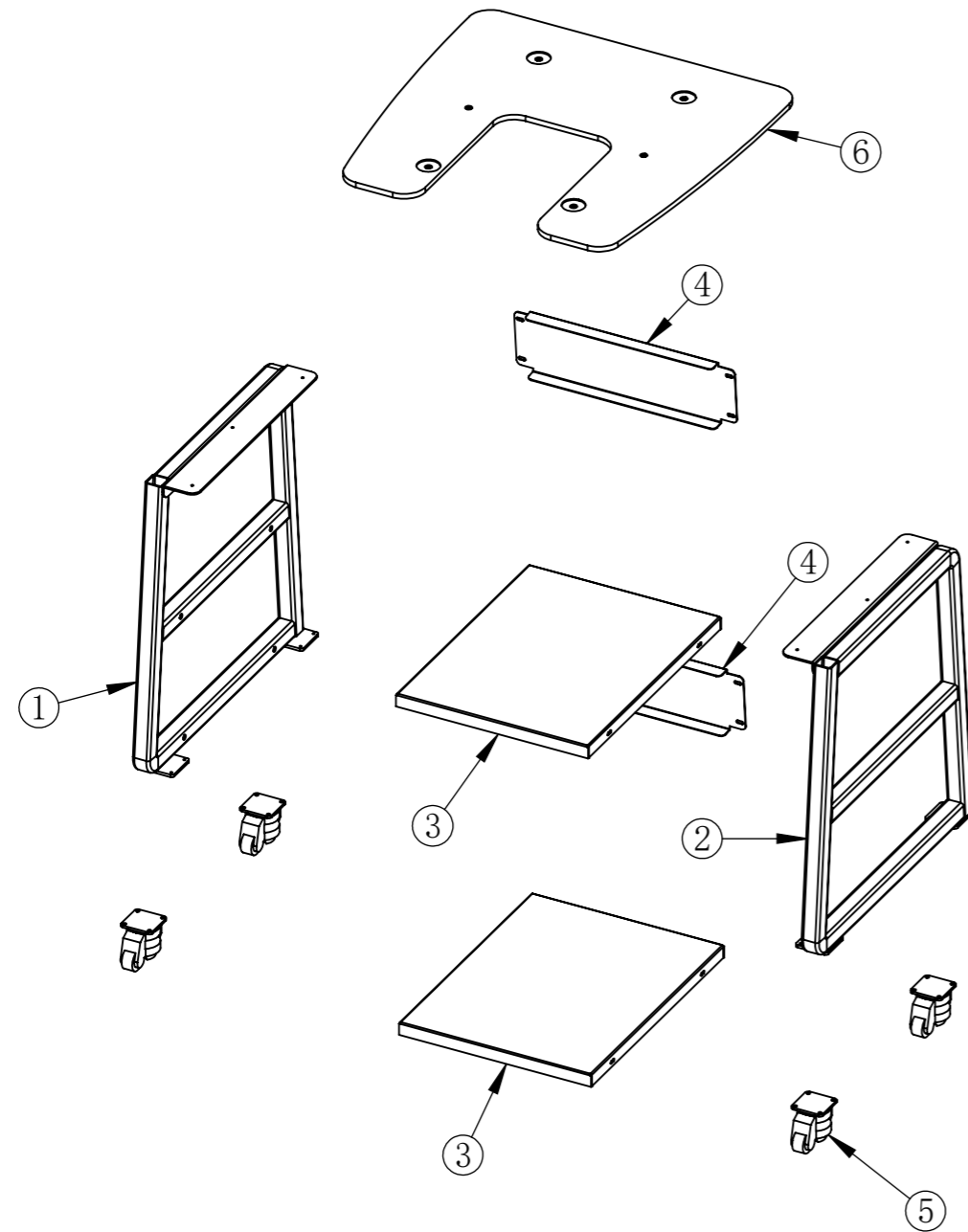

## 12 Stand 家用机底架

No.	Chinese Description	Description	Part No.	Qty
1	底架侧档 - 左	Side Frame L	0110120001	1
2	底架侧档 - 右	Side Frame R	0110120002	1
3	下平板	Lower Plate	0110120003	2
4	后侧上板	Back Plate	0110120004	2
5	脚轮BS-60	Wheels BS-60	0210010004	4
6	台板 - 方管后联	Table	0110130001	1



13 Embroidery Frame 花架

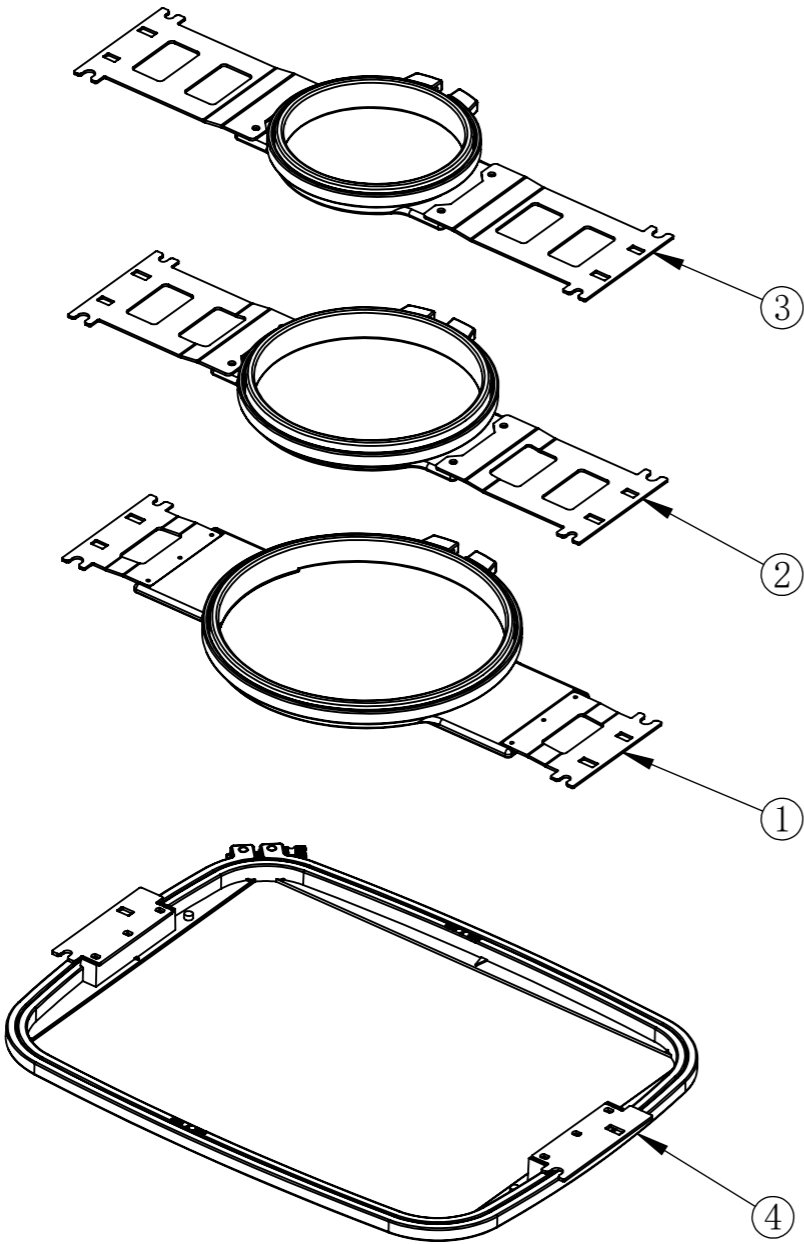

13 Embroidery Frame 花架

No.	Chinese Description	Description	Part No.	Qty
1	圆形绣框装配体190mm	Round Frame-190	0110190001	1
2	圆形绣框装配体150mm	Round Frame-150	0110190002	1
3	圆形绣框装配体120mm	Round Frame-120	0110190003	1
4	花架320 240装配体	Rectangle Frame	0110190004	1

# 14 Cap Stand Frame 帽绣组件

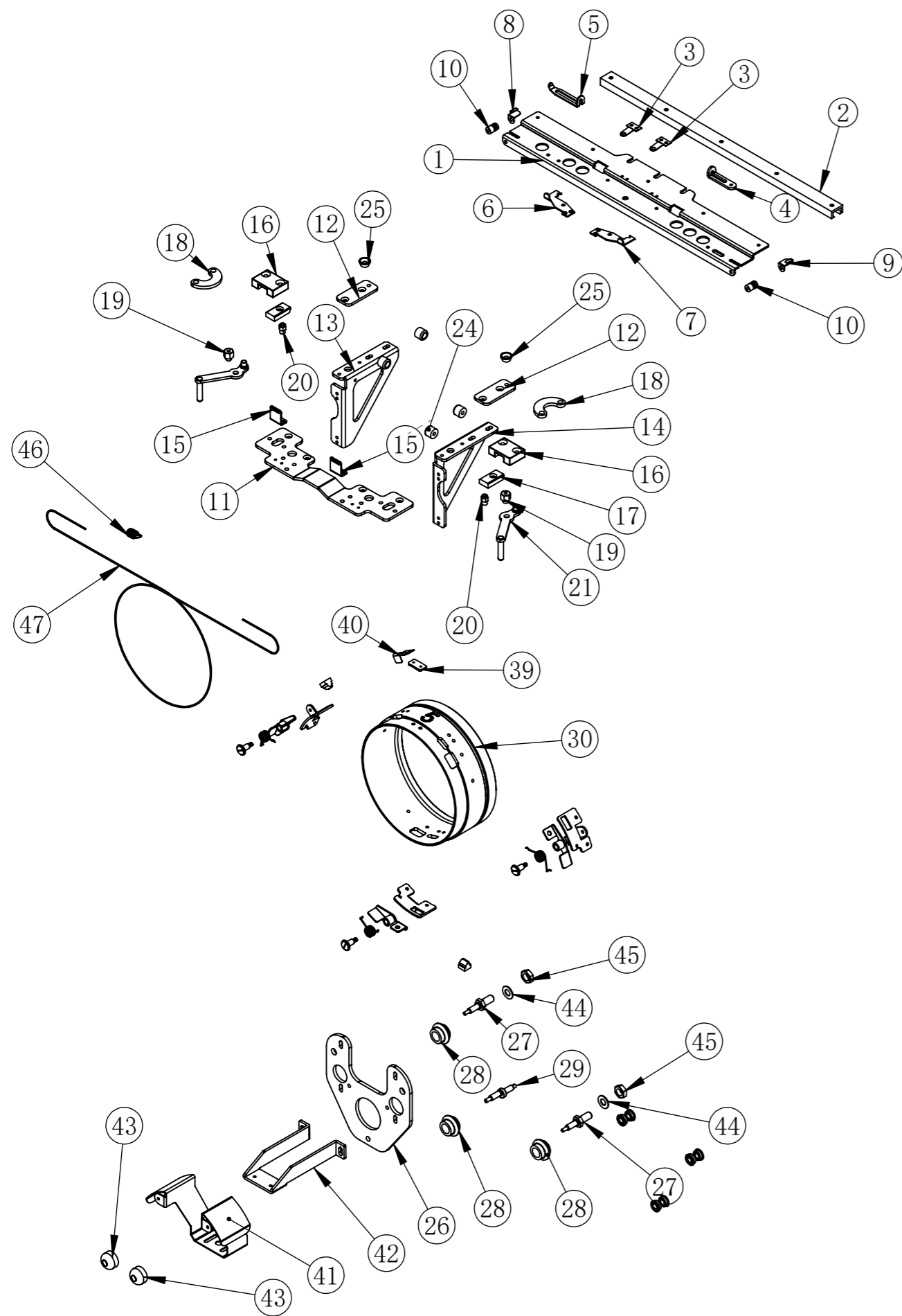

200220

# 14 Cap Stand Frame 帽绣组件

No.	Chinese Description	Description	Part NO.	Qty
1	上大铝板	Main Plate	0110200020	1
2	尼龙长条	Nylon Guide	0110200021	1
3	弹性片	Shrapnel	0110200022	2
4	钢丝调节块1	Regulating Block	0110200023	1
5	钢丝调节勾	Adjusting Hook	0110200024	1
6	扣片	Gusset Plate	0110200025	2
7	镜向扣片	Gusset Plate	0110200026	1
8	固定弹片	Fixing Plate	0110200027	2
9	镜向固定弹片	Fixing Plate	0110200028	1
10	钢丝过道	Wire Aisle	0110200029	2
11	凸性铝板	Concave-Convex Plate	0110200030	1
12	前后调节铝片	Adjusting Panel	0110200031	2
13	左脚	Left Foot	0110200032	2
14	镜向左脚	Right Foot	0110200033	1
15	锁片	Lock Seat	0110200034	2
16	轨道铝块	Guide Block	0110200035	2
17	70度前压块	Movable Block	0110200036	2
18	旋转扣	Rotating Buckle	0110200037	2
19	旋转螺母	Nuts	0110200038	2
20	旋转螺母 - 滑块处	Rotating Nuts	0110200039	2
21	旋转摇柄	Handle	0110200040	2
24	尼龙导向块 - 支架	Nylon Block	0110200041	4
25	70度后压块	Limit Ring	0110200042	2
26	滚轮底板	Bottom Plate	0110200043	1
27	轮心轴	Pin A	0110200044	2
28	配偏心轴尼龙轮-2	Wheel	0110200045	3
29	偏心轴-2	Pin B	0110200046	1
30	帽圈 - 圆弧槽	Circle	0110200047	1
39	卡口小铁片	Metal plate	0110200048	1
40	边圈勾片	Shrapnel	0110200049	3
41	前支架 - 外	Anterior Bracker A	0110200050	1
42	前支架 - 里	Anterior Bracket B	0110200051	1
43	尼龙导向轮	Guide Wheel	0110200052	2
44	16垫片	Spacer		3
45	螺母	Nuts		3
46	钢丝弹簧	Spring	0110200053	1
47	钢丝	Wire	0110200054	1
48	带台阶轴承D12d6H4	Bearing		6

# 15 Cap Frame Parts 帽座

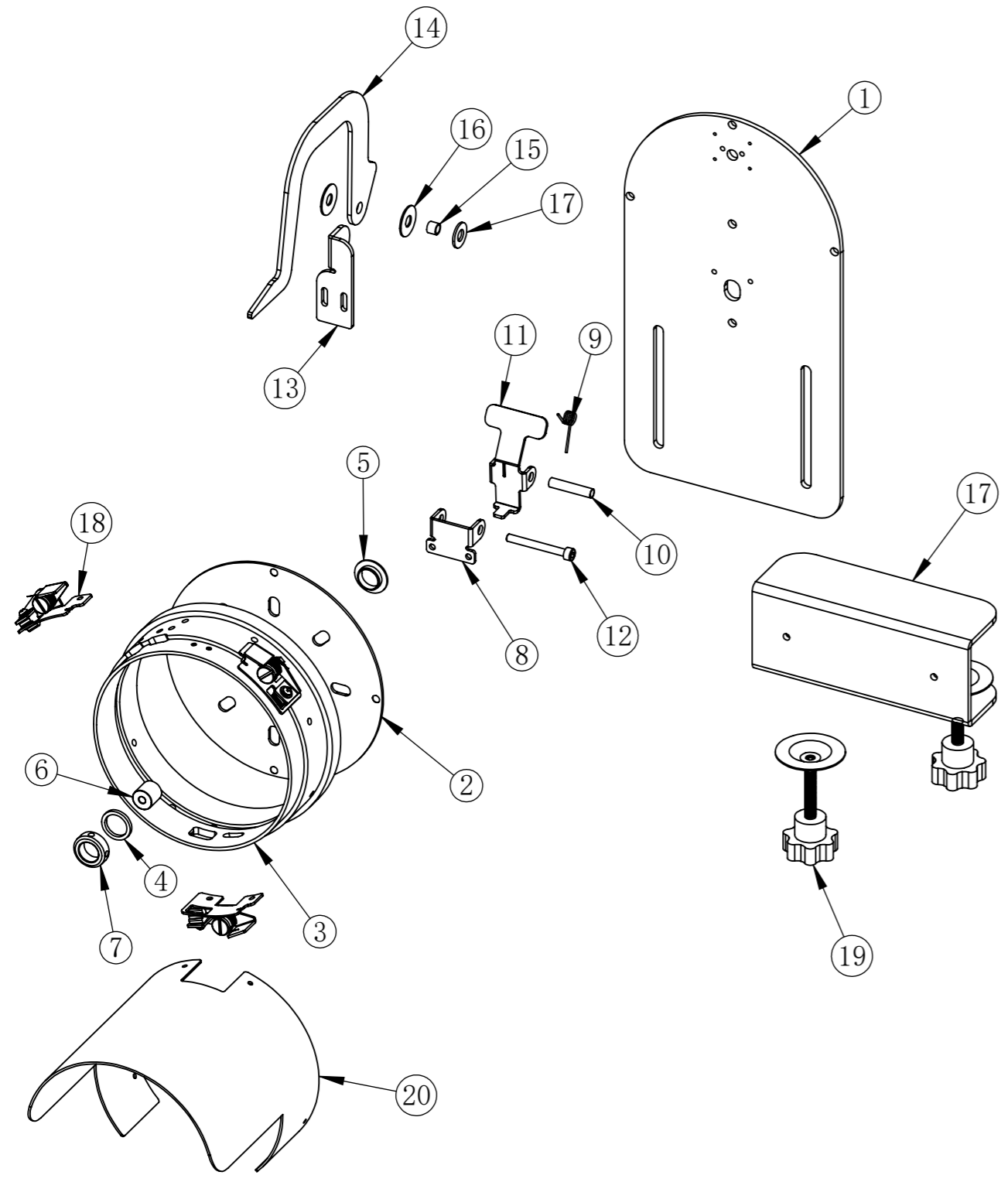

# 15 Cap Frame Parts 帽座

No.	Chinese Description	Description	Part No.	Qty
1	帽架支架平板 - 带旋转	Cap Frame Main Su	0110200003	1
2	帽架帽圈后板	Back Palte	0110200004	1
3	帽座帽圈	Cap Tube	0110200005	1
4	轴芯尼龙隔套	Ring	0110200006	1
5	轴芯耐磨衬套	plastics Collar	0110200007	1
6	轴芯 - 旋转	Pin	0110200008	1
7	轴芯挡圈	Collar	0110200009	1
8	扳扣底板	Trigger Base Plate	0110200010	1
9	扳扣扭簧	Trigger Spring	0110200011	1
10	扳扣转轴	Trigger Shaft	0110200012	1
11	扳扣板	Trigger	0110200013	1
12	M5螺丝 - 45半牙	Screw		1
13	对位板底板	Location Base Plate	0110200014	1
14	对位板	Location Plate	0110200015	1
15	对位板空心转轴	Location Shaft	0110200016	1
16	尼龙垫片D22d8H1	Insulation Spacer	0110200017	2
17	帽架支架U板	Support U Plate	0110200019	1
18	料夹片A	Snap		1
19	帽座手柄A	Handle A	103240011	2
20	帽檐	Brim of a hat	103240006	1