

PARTS LIST

TMBR-SC

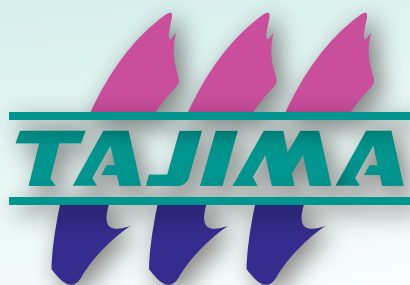

Table of Contents

● GENERAL VIEW	
● FRAMING.....	E1-1
● MAIN SHAFT DRIVE SYSTEM.....	E1-2
● CYLINDER BED.....	E1-3
● COLOR CHANGE SYSTEM.....	E1-4
● ARM 1.....	E1-5-1
● ARM 2.....	E1-5-2
● ARM 3.....	E1-5-3
● NEEDLE BAR CASE 1.....	E1-6-1
● NEEDLE BAR CASE 2A (6-NEEDLE M/C).....	E1-6-2a
● NEEDLE BAR CASE 2B (12, 15-NEEDLE M/C).....	E1-6-2b
● X-AXIS DRIVE SYSTEM.....	E1-7
● Y-AXIS DRIVE SYSTEM.....	E1-8
● TENSION BASE.....	E1-9
● THREAD STAND.....	E1-10
● OPERATION PANEL.....	E1-11
● ELECTRICAL PARTS.....	E1-12
● TABLE, BORDER FRAME (OPTION).....	E1-13
● SIGNAL TOWER, STAND (OPTION).....	E1-14
● OPTION (POSITION MARKER).....	E1-15
● X-EXTENSION UNIT 1 (OPTION).....	E1-16-1
● X-EXTENSION UNIT 2 (OPTION).....	E1-16-2

Part Nos. of screws, nuts, washers etc. are listed at the end of volume.

*Regarding the part number that contains description of @, the part differs depending on model, spec. etc.

*When you place an order of such a part, please also inform us of your model, embroidery space and manufacturing number of the machine.

Ex.	TMBR-S1501C	360 x 500S	No.E1X01234
	[Model]	[Emb. Space]	[Mfg. No.]

GENERAL VIEW

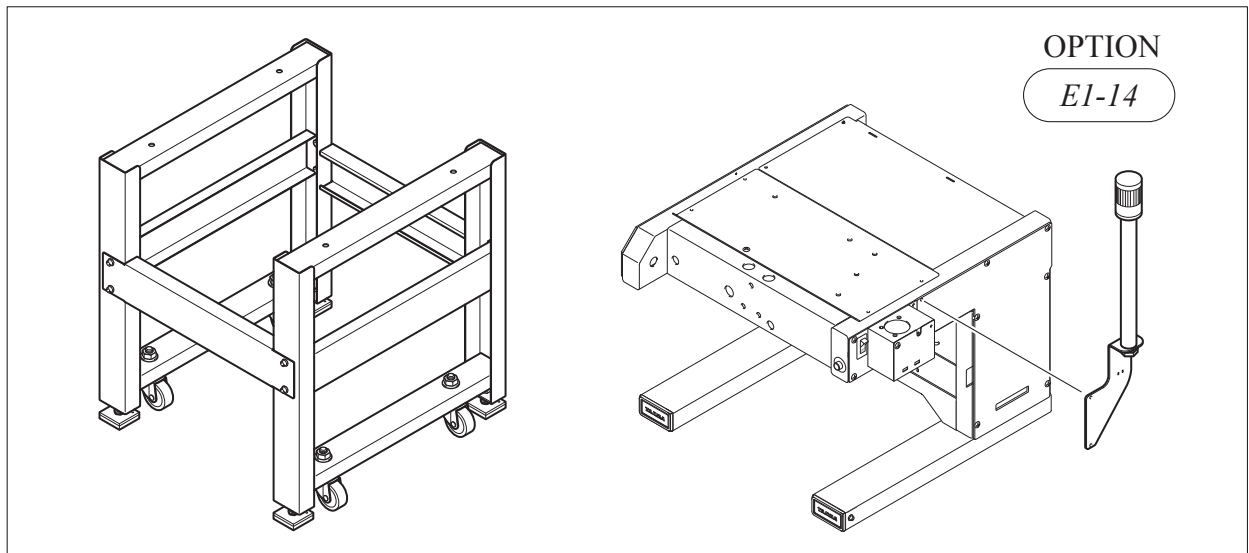
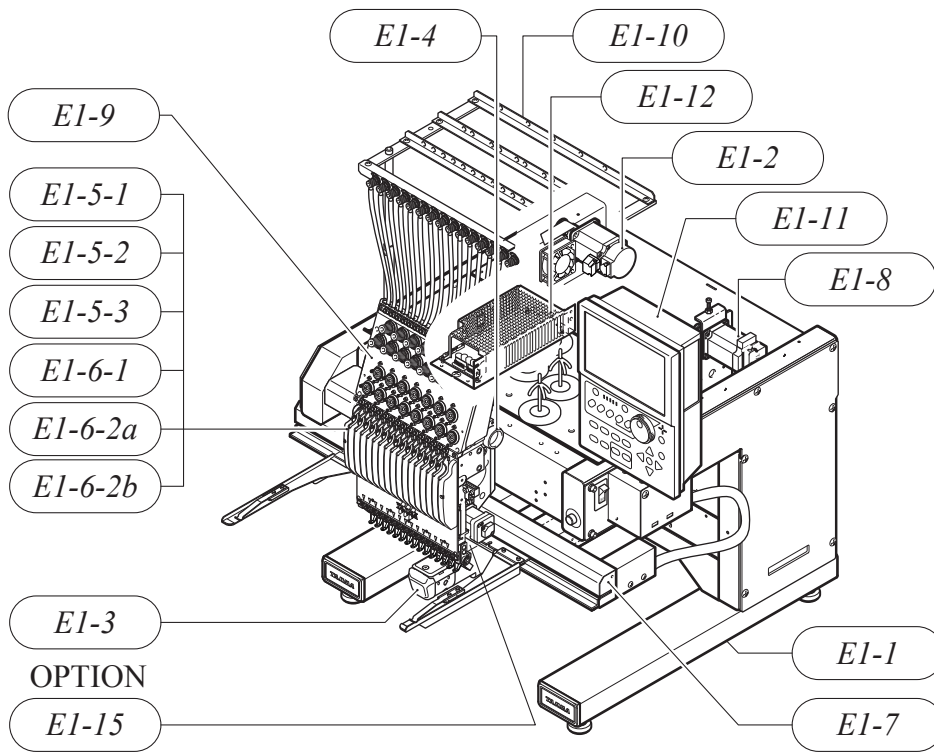
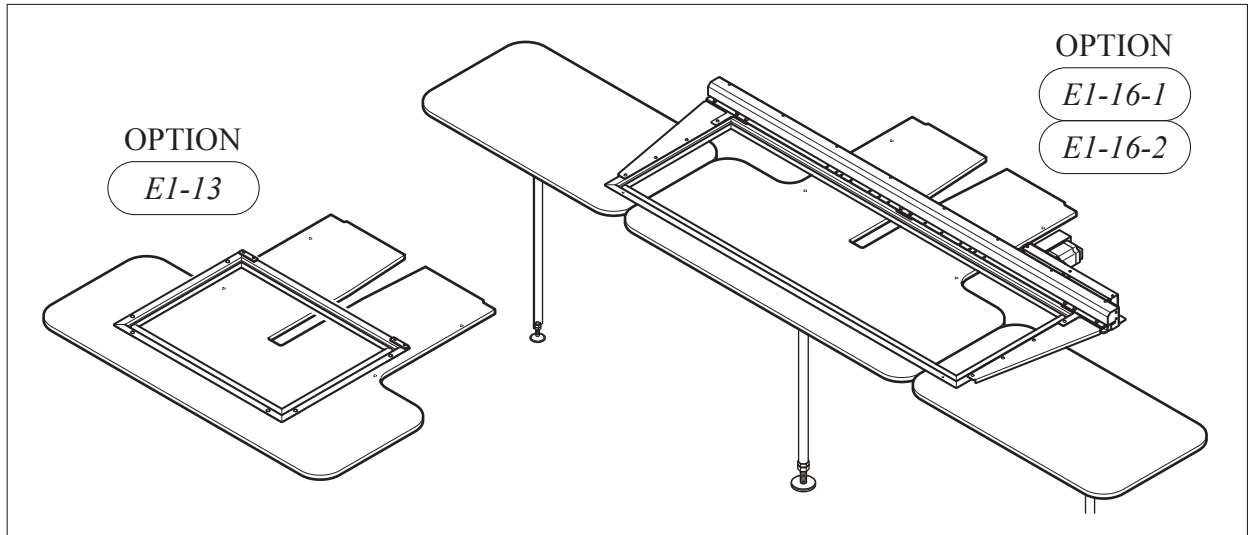

FRAMING

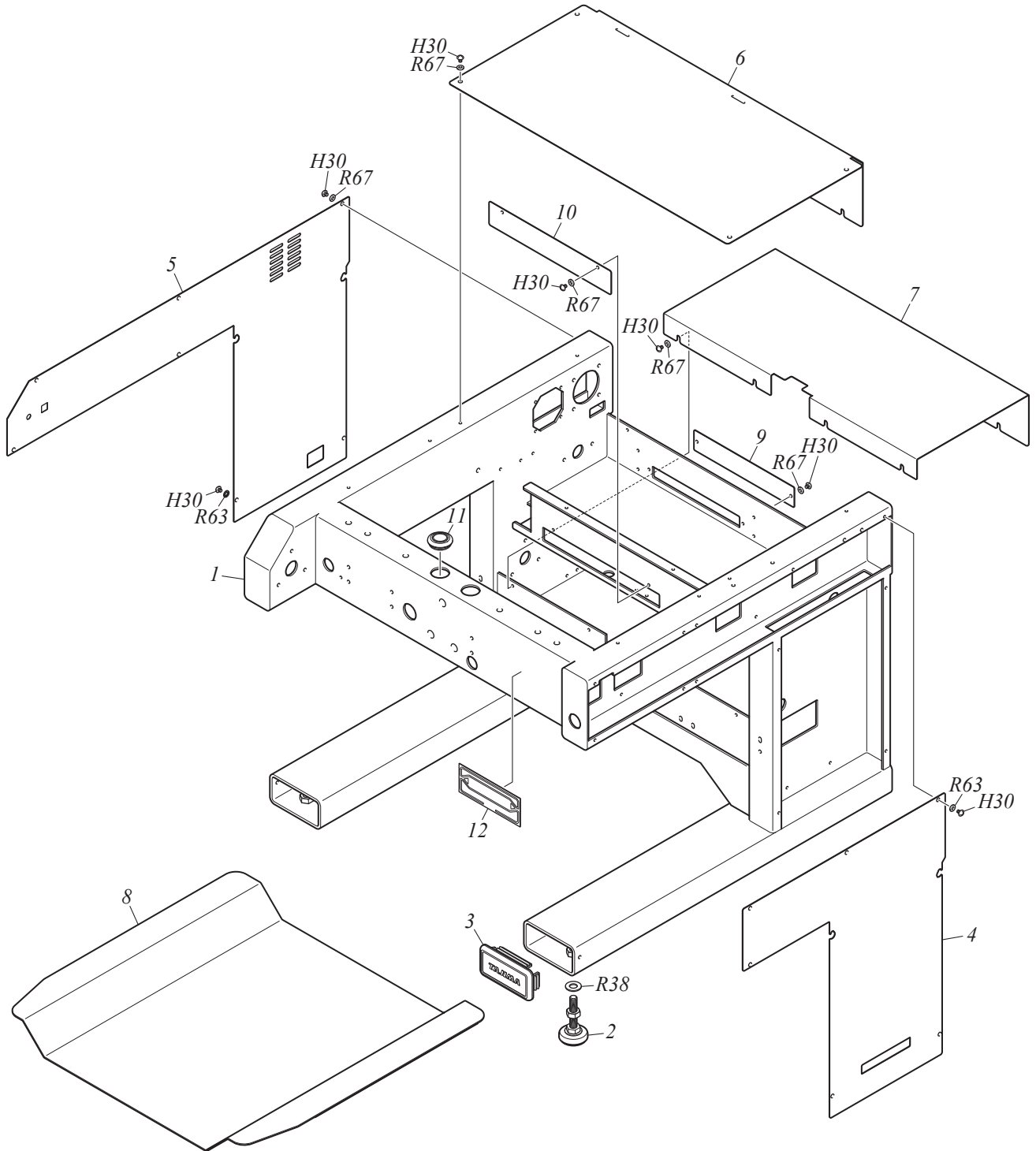

FRAMING

E1-1

No.	Part Name	Part No.	Remark
1	STAND :0001/036*500S	NE115001@010	
2	RUBBER BASE ADJUSTER :M10	614300240000	
3	COVER :STAND BASE	030440610010	
4	COVER :RIGHT-SIDE BOX	03044065@000	
5	COVER :LEFT-SIDE BOX	03044066@000	
6	COVER :STAND :UPPER	03044067@000	
7	COVER :STAND :LOWER	03044068@000	
8	TRAY :STAND[S]	0L3110160S00	Option
9	COVER :STAND :REAR	03044069@000	
10	COVER :STAND :FRONT	030440700000	
11	GROMMET WITH FILM :26A	644500210000	
12	MAIN NAME PLATE :TMBR-SC	14E1100@0000	
13			
14			
15			
16			
17			
18			
19			
20			
21			
22			
23			
24			
25			
26			
27			
28			
29			
30			
31			
32			
33			
34			
35			
36			
37			
38			
39			
40			
41			
42			
43			
44			
45			
46			
47			
48			
49			
50			

Note: As for parts with mark @, please follow our instructions on Table of Contents in your parts order.

(U004)

MAIN SHAFT DRIVE SYSTEM

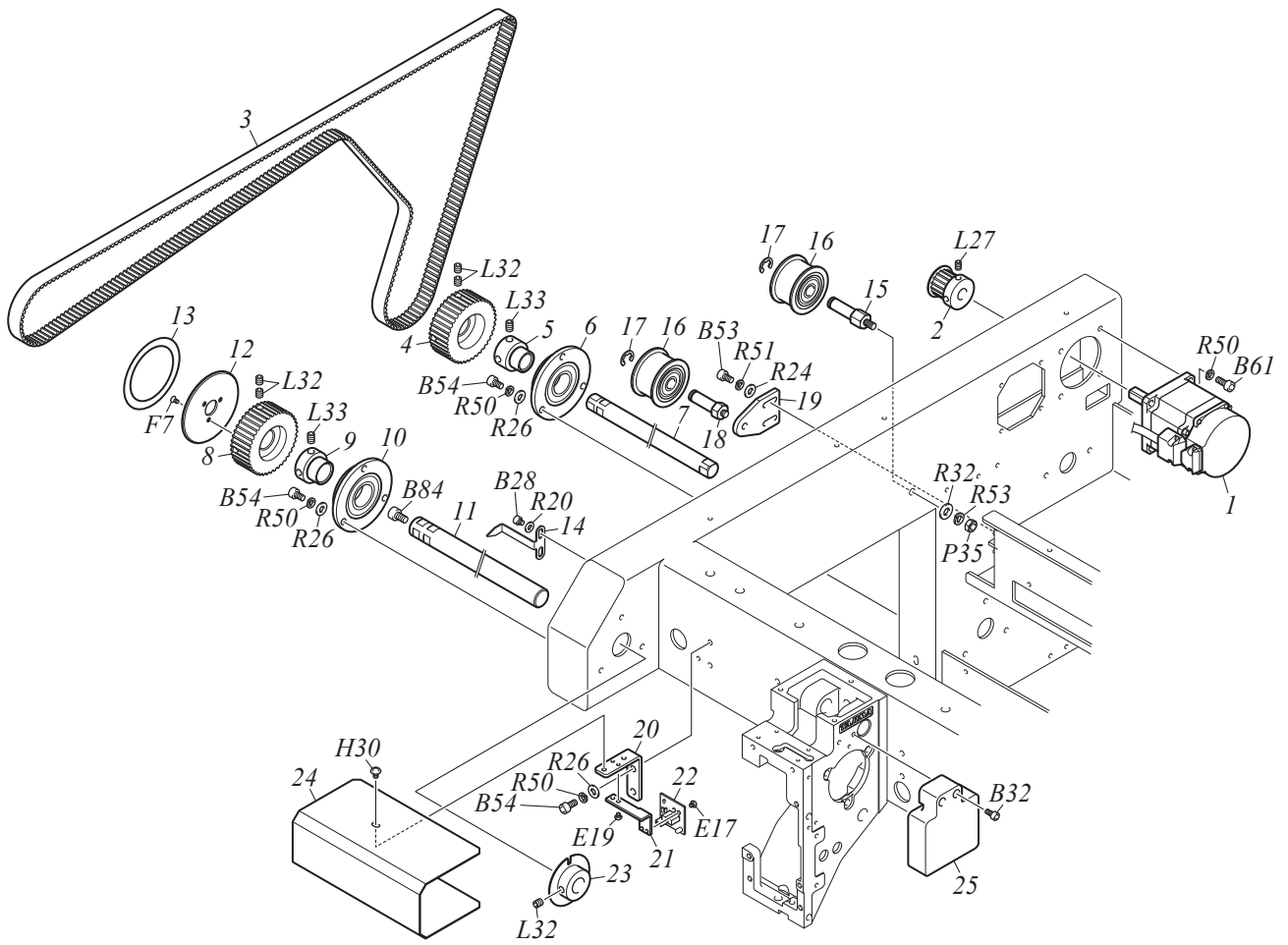

MAIN SHAFT DRIVE SYSTEM

E1-2

No.	Part Name	Part No.	Remark
1	SERVO MOTOR :188W	0J6301700000	
2	TIMING PULLEY :MAIN SHAFT :W15-16[S]	501430150S00	
3	TIMING BELT :SPTG :W15-S5M1680/GB	623200500000	
4	TIMING PULLEY :B :W15-40	50143303B000	
5	BEARING COLLAR :15MM DIA.	502715040010	
6	BEARING CASE :NO.2 :20MM DIA.[S]	508220060S00	
7	ROTARY HOOK SHAFT :15P*340	QS3102010000	
8	TIMING PULLEY :B :W15-40	50143305B000	
9	BEARING COLLAR :18MM DIA.	502718010010	
10	BEARING CASE :NO.2 :22MM DIA.[S]	508222020S00	
11	MAIN SHAFT :18P*347.5	QS3101010000	
12	BASE :ANGLE INDICATOR	040120260000	
13	ANGLE INDICATOR	040420230010	
14	POINTER	040410220000	
15	SCREW WITH ROLLER PIN :NO.3 :M6	514306020000	
16	FLAT PULLEY :40MM DIA.[S]	501902050S00	
17	E-RING :7MM DIA.	611100100000	
18	SCREW WITH ROLLER PIN :NO.3 :M6	514306030000	
19	BASE :IDLER	040150030000	
20	BASE :SENSOR :WITHOUT SPACER	040360040010	
21	BRACKET :SENSOR	040360020010	
22	CARD :PHOTO-INTERRUPTER	0J4204500000	
23	ROTATING DETECTING PLATE[S]	040360050S10	
24	SHAFT COVER	17018007@000	
25	HEAD COVER :SINGLE HEAD M/C :R	080430310000	
26			
27			
28			
29			
30			
31			
32			
33			
34			
35			
36			
37			
38			
39			
40			
41			
42			
43			
44			
45			
46			
47			
48			
49			
50			

Note: As for parts with mark @, please follow our instructions on Table of Contents in your parts order.

(U004)

CYLINDER BED

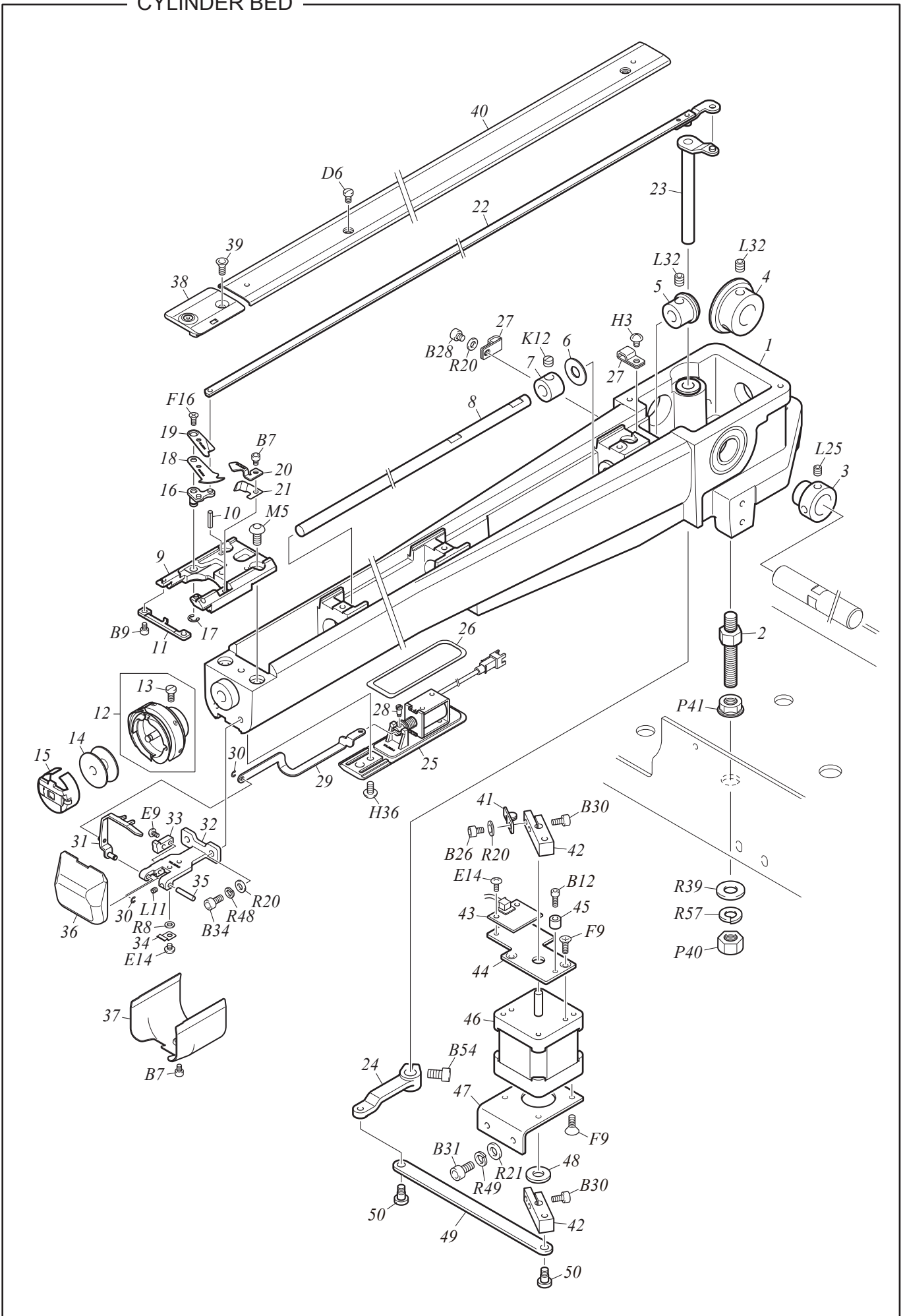

CYLINDER BED

E1-3

No.	Part Name	Part No.	Remark
1	LONG CYLINDER BED[S]	050170030S00	
2	ROTARY HOOK BASE STUD	050330330000	
3	BEARING COLLAR :15MM DIA.	502715080000	
4	SPIRAL BEVEL GEAR :NO.1 :28T	506528030000	
5	SPIRAL BEVEL GEAR :NO.1 :14T	506514030000	
6	PLAIN WASHER :7.94*19*T0.8	519108030000	
7	STOPPER COLLAR :7.94MM DIA.	502107020000	
8	SHAFT :ROTARY HOOK :7.94MM DIA.	050330550000	
9	NEEDLE PLATE BRACKET[S]	050330640S00	
10	SPRING PIN :3*12	611400080000	
11	ROTARY HOOK SUPPORT	050330660000	
12	ROTARY HOOK :KHS12-RYPTFSOE	050230090010	
13	ROTARY HOOK SET SCREW :11/64*7.2	050290020000	
14	BOBBIN :REGULAR ROTARY HOOK	050260010020	
15	BOBBIN CASE :REGULAR ROTARY HOOK :STANDARD	050240150000	
16	LEVER SHAFT :KNIFE[S]	050321510S00	
17	E-RING :4MM DIA.	611100070000	
18	THREAD SEPARATING PLATE :DIRECT MOVEMENT 2-BLADE TYPE	050320930010	
19	MOVABLE KNIFE :DIRECT MOVEMENT 2-BLADE TYPE	050320920010	
20	FIXED KNIFE :DIRECT MOVEMENT 2-BLADE TYPE	050321520000	
21	UNDER THREAD PRESSER	050321530000	
22	CONNECTING PLATE :KNIFE[S]	050321550S00	
23	LEVER SHAFT :KNIFE CONNECTING PLATE[S]	050320850S20	
24	LEVER :KNIFE CONNECTING PLATE SHAFT	050321000000	
25	BASE :SOLENOID[A]	050321450A00	
26	RUBBER PACKING	050321560000	
27	CORD CLAMP	644100040000	
28	STEPPED SCREW :NO.1 :M2.5*6	512130010010	
29	CONNECTING PLATE :PICKER	050321480000	
30	E-RING :2MM DIA.	611100050000	
31	PICKER[S]	050321470S10	
32	HOLDER :PICKER	050321490000	
33	STOPPER :PICKER	050320700000	
34	PLATE SPRING :ROTARY HOOK COVER :T0.3	507802060000	
35	STRAIGHT PIN :NO.1 :3MM DIA.	503101100000	
36	ROTARY HOOK COVER[S]	050330680S00	
37	COVER :NEEDLE PLATE BRACKET	050330670000	
38	NEEDLE PLATE	05034055@010	
39	HEXAGON SOCKET HEAD COUNTERSUNK SCREW :M4*8	S125040801MZ	
40	COVER :CYLINDER BED :FRONT	050330700000	
41	SENSOR PLATE :NO.1	050320110000	
42	LEVER :ATH	050320100000	
43	CARD :MAGNETIC SENSOR A	0J4204400000	
44	BASE :SENSOR	050321590000	
45	DAMPER RING :3MM DIA. E	050320470010	
46	PULSE MOTOR :42MM SQUARE :DOUBLE-END	0J6106200000	
47	BASE :ATH MOTOR	050321580000	
48	PLASTIC WASHER :6*15*T2.5	519206020000	
49	CONNECTING PLATE :ATH DRIVE ARM	050320430000	
50	STEPPED SCREW :NO.1 :M4*6.7	512104100040	

Note: As for parts with mark @, please follow our instructions on Table of Contents in your parts order.

(U004)

COLOR CHANGE SYSTEM

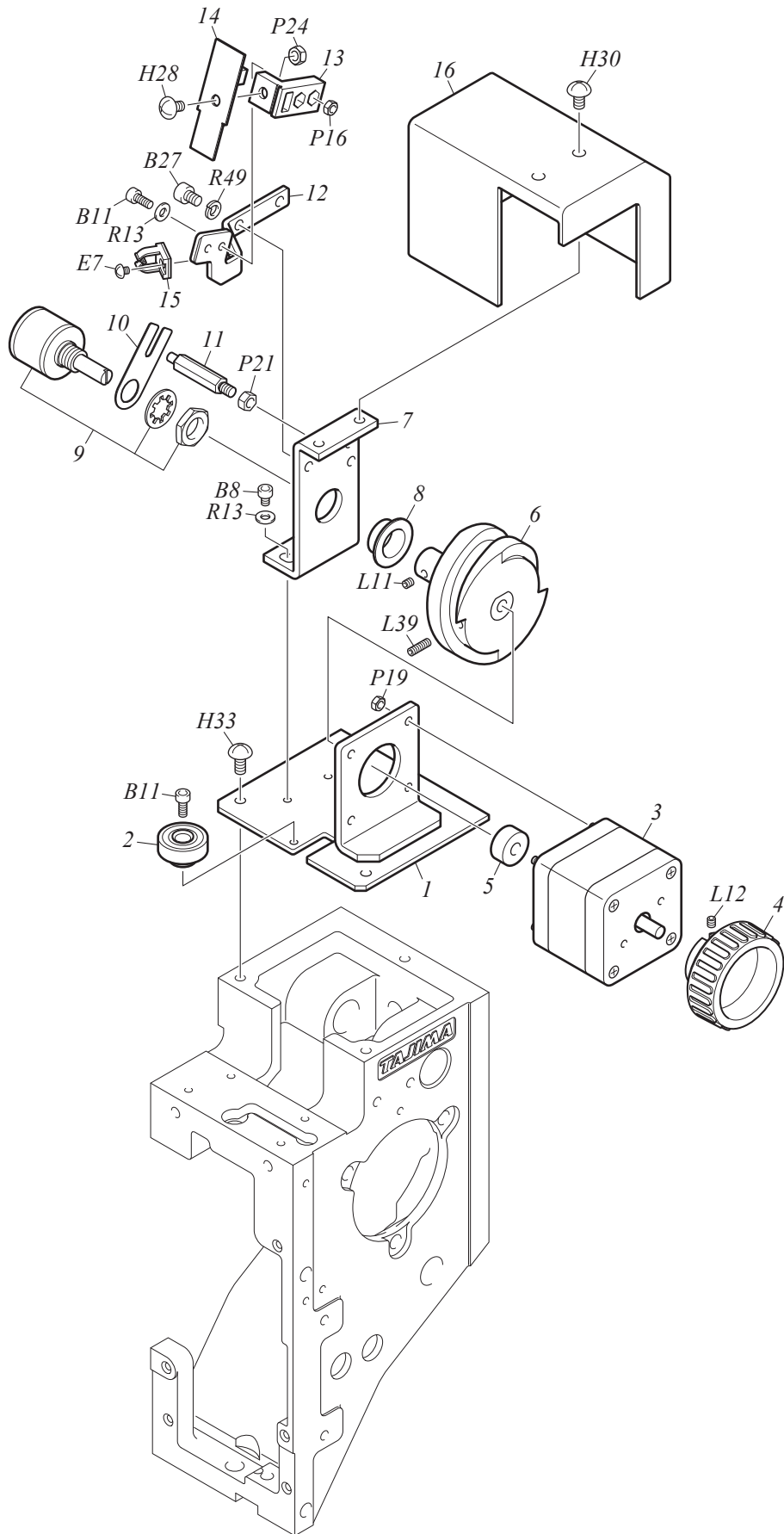

COLOR CHANGE SYSTEM

E1-4

No.	Part Name	Part No.	Remark
1	BASE :CHANGE MOTOR	070110340020	
2	ROLLER PIN[S]	080290040S10	
3	PULSE MOTOR :42MM SQUARE :DOUBLE-END[T]	0J6110700T10	
4	KNOB :B	08052001B010	
5	COLLAR :NO.1 :5.1MM DIA.	502551010010	
6	CAM :CHANGE[S]	070110480S00	
7	BEARING CASE :CHANGE CAM	070110370010	
8	OIL-BUSHING :NO.2 :MB0206-20FDU	638100240000	
9	POTENTIOMETER	640900010001	
10	BRACKET :POTENTIOMETER	0C0420020010	
11	STUD :NO.4 :M4-27.5	505404030020	
12	SENSOR ARM	0C0230350010	
13	BASE :CARD	0C0230340000	
14	CARD :TC SENSOR :MAGNETIC TYPE	0J2603000000	
15	MINI CLAMP :MB-3	644100200000	
16	COVER :CHANGE	070110050010	
17			
18			
19			
20			
21			
22			
23			
24			
25			
26			
27			
28			
29			
30			
31			
32			
33			
34			
35			
36			
37			
38			
39			
40			
41			
42			
43			
44			
45			
46			
47			
48			
49			
50			

Note: As for parts with mark @, please follow our instructions on Table of Contents in your parts order.

(U004)

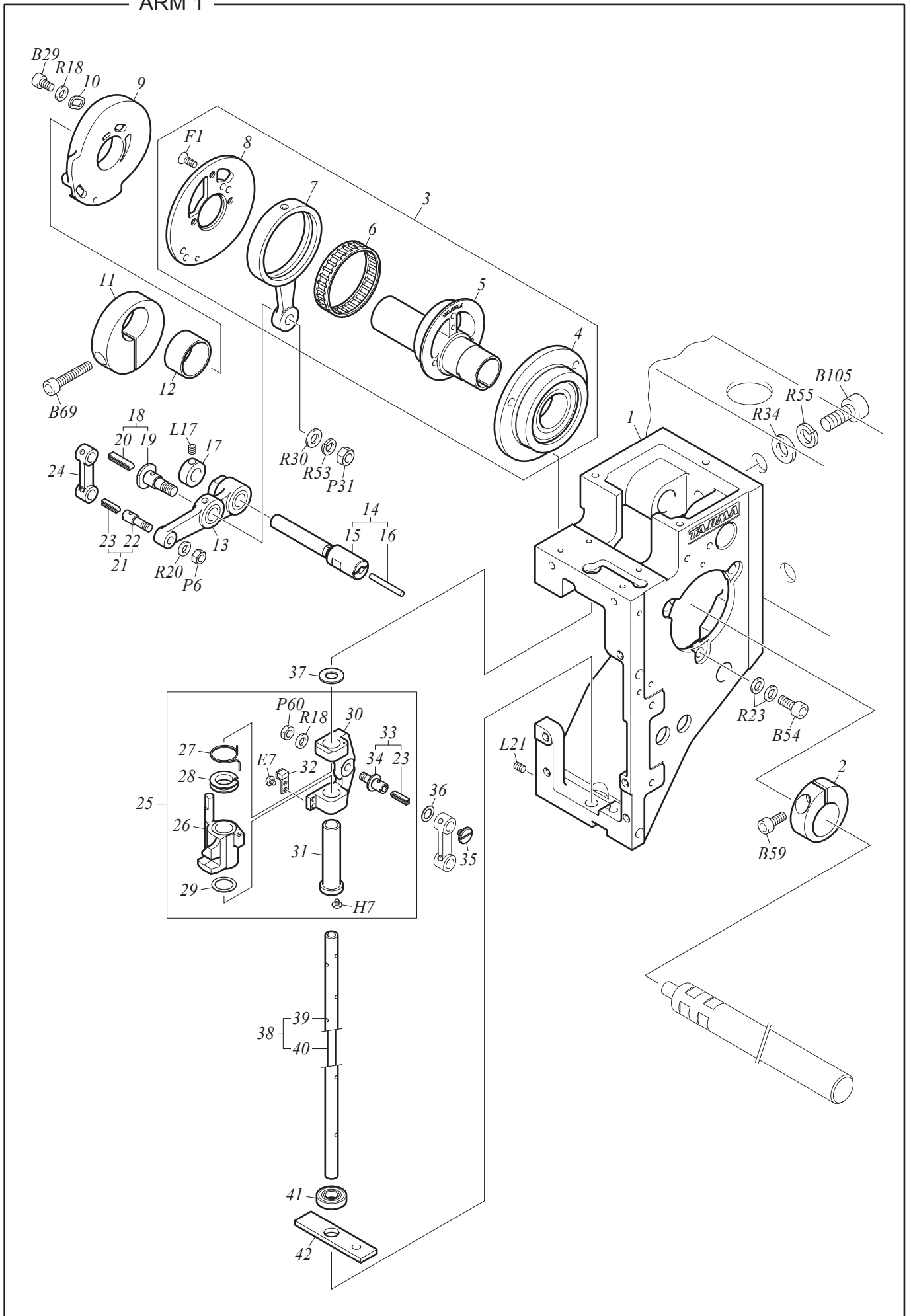

ARM 1

E1-5-1

No.	Part Name	Part No.	Remark
1	HEAD	080120040000	
2	TIGHTENING COLLAR :21MM DIA.	502221010010	
3	CAM :NEEDLE BAR[A]	080220010A00	
4	BEARING CASE :NO.2 :22MM DIA.[S]	508222010S00	
5	CAM :NEEDLE BAR	080220010000	
6	NEEDLE CAGE :KT404310NE01B2	634400070001	
7	CONNECTING ROD :51.7	080220040000	
8	BASE :TAKE-UP LEVER CAM	080220400000	
9	CAM :TAKE-UP LEVER :M6 :REGULAR ROTARY HOOK	080220430000	
10	WASHER :CAM	080220180000	
11	BALANCER :HEAD	080290310000	
12	SPACER :BALANCER	080290320000	
13	LEVER :NEEDLE BAR[S]	080230390S00	
14	STEPPED PIN :NO.4[S]	503204070S00	
15	STEPPED PIN :NO.4	503204070000	
16	WICK :3P*61	080240230000	
17	STOPPER COLLAR :8MM DIA.	502108020010	
18	STEPPED SCREW :NO.2 :M6*13[S]	512206010S10	
19	STEPPED SCREW :NO.2 :M6*13	512206010010	
20	WICK :3.5*1*34	080240140000	
21	SCREW WITH PIN :NO.3 :11/64-7.7[A]	513354020A10	
22	SCREW WITH PIN :NO.3 :11/64-7.7	513354020010	
23	WICK :2.5*1*22	080240120010	
24	CONNECTING ROD :26	080230010000	
25	NEEDLE BAR RECIPROCATOR[A]	080210680A00	
26	NEEDLE BAR RECIPROCATOR	080210670000	
27	TORSION SPRING :0.7MM DIA.	507307010010	
28	HOLDER :JUMP SPRING	080210110010	
29	PLAIN WASHER :10.3*14*T0.5	519112010000	
30	RECIPROCATING SLIDE BLOCK	080210660000	
31	PLASTIC BUSHING :NO.2 :7.24MM DIA.	509472050010	
32	DAMPER BRACKET :NEEDLE BAR RECIPROCATOR	080210090000	
33	SCREW WITH PIN :NO.3 :11/64-7.9[A]	513354060A20	
34	SCREW WITH PIN :NO.3 :11/64-7.9	513354060020	
35	FLAT FILLISTER HEAD SCREW :9/64*4	511153010010	
36	PLAIN WASHER :6*9.5*T0.05-0.5	51910604@020	
37	FELT :14MM DIA.	080240060000	
38	NEEDLE BAR DRIVE SHAFT :AUTOMATIC LUBRICATION[S]	0L0210030S00	
39	NEEDLE BAR DRIVE SHAFT :AUTOMATIC LUBRICATION	0L0210030000	
40	WICK :3.5P*183	080240020010	
41	GUIDE :NEEDLE BAR CASE[S]	080250170S20	
42	FELT :NEEDLE BAR DRIVE SHAFT	080240270000	
43			
44			
45			
46			
47			
48			
49			
50			

Note: As for parts with mark @, please follow our instructions on Table of Contents in your parts order.

(U004)

12, 15-Needle

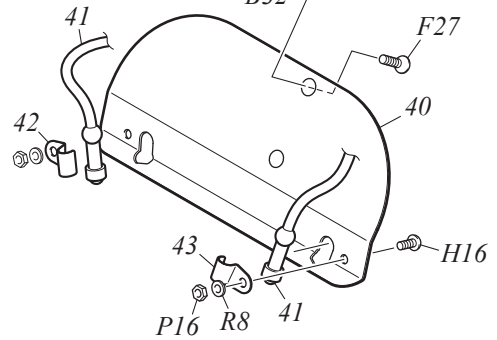
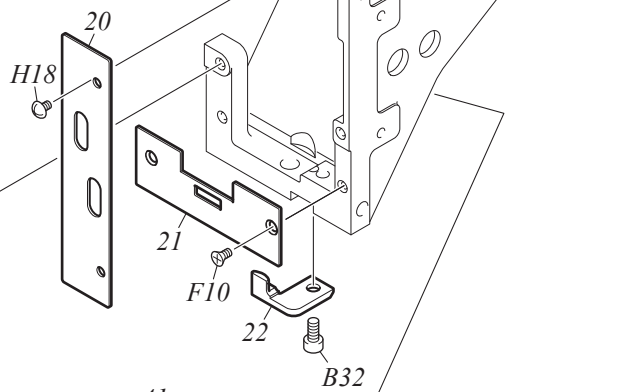
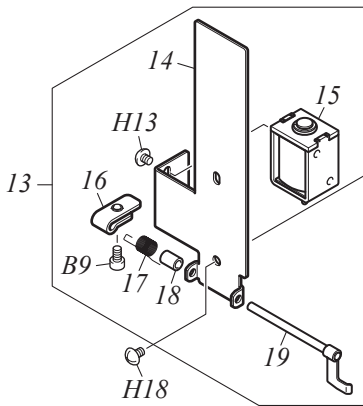
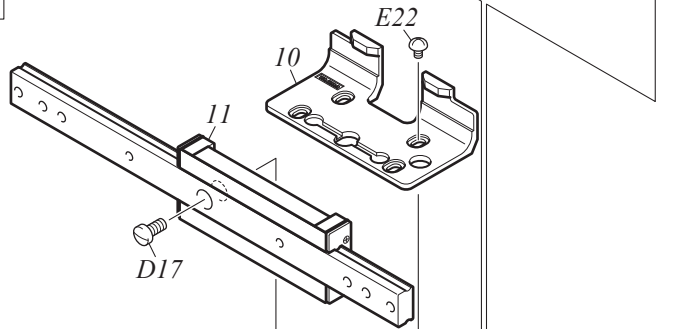
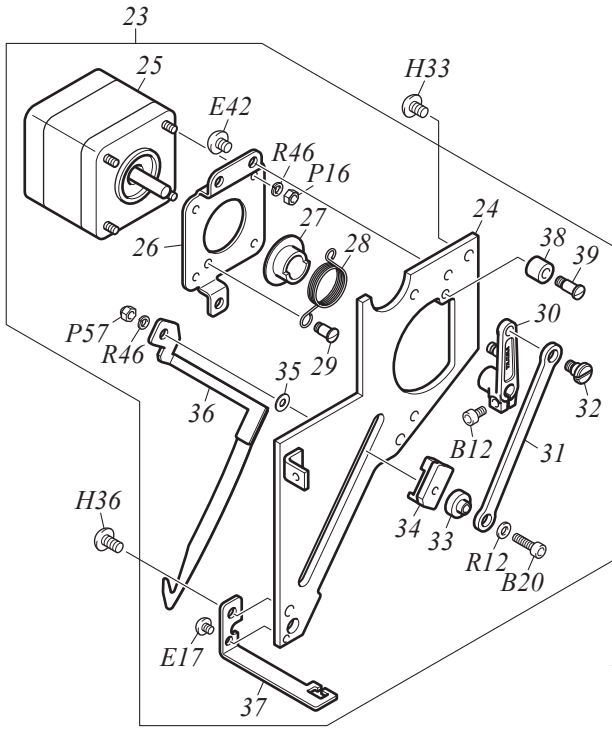
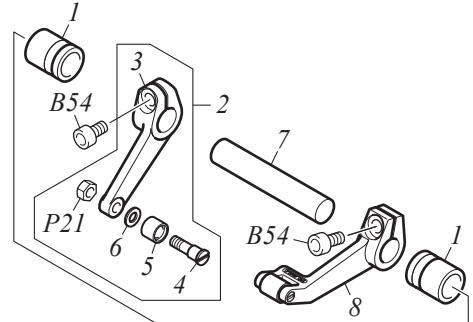
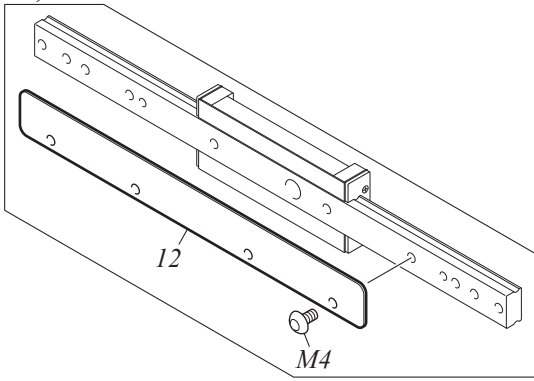

ARM 2

E1-5-2

No.	Part Name	Part No.	Remark
1	BEARING BUSHING :NO.1 :10MM DIA.	509510020000	
2	LEVER :TAKE-UP LEVER[S]	080230380S00	
3	LEVER :TAKE-UP LEVER	080230380000	
4	STEPPED SCREW :NO.1 :M4*5.3	512104160020	
5	ROLLER :5*8*5	515105020010	
6	PLAIN WASHER :4*7.5*T0.8	519104060000	
7	STRAIGHT PIN :NO.1 :10MM DIA.	503101580000	
8	ARM :TAKE-UP LEVER[S]	080230270S00	
9	LID :TAKE-UP LEVER SHAFT HOLDER :15.3MM DIA.	080290270000	
10	TAKE-UP LEVER GUIDE	080250210000	
11	LINEAR WAY :NEEDLE BAR CASE	08025004@000	
12	REINFORCING PLATE	08025005@000	
13	HEAD FRONT COVER :L[A]	08042030LA00	
14	HEAD FRONT COVER :L	08042030L000	
15	SOLENOID :OPEN FRAME	640600121001	
16	LEVER :SOLENOID	080270010010	
17	TORSION SPRING :0.5MM DIA.	507305020020	
18	COLLAR :NO.1 :3.1MM DIA.	502505010000	
19	LEVER :DRIVE[S]	080270040S10	
20	HEAD FRONT COVER :R	08042031R000	
21	GUIDE PLATE :NEEDLE BAR CASE	080250220000	
22	GUIDE BRACKET :NEEDLE BAR CASE	080250200000	
23	UPPER THREAD HOLDER[A]	0B0110740A00	
24	SIDE COVER :HEAD :LOWER	080430220000	
25	PULSE MOTOR :42MM SQUARE :DOUBLE-END[T]	0J6110700T10	
26	BASE :HOOK MOTOR	0B0110420000	
27	COLLAR :SPRING GUIDE	502522010010	
28	TORSION SPRING :0.8MM DIA.	507308190010	
29	STEPPED SCREW :NO.1 :9/64*7.5	512153040000	
30	LEVER :HOOK	0B0110470000	
31	CONNECTING PLATE :HOOK	0B0110080010	
32	STEPPED SCREW :NO.1 :M4*6.7	512104100040	
33	SPACER :SLIDE HOOK	0B0110370010	
34	SLIDE :HOOK	0B0110510000	
35	WASHER :2.6*7*T0.5	519204010000	
36	HOOK[S]	0B0110650S10	
37	GUIDE :HOOK	0B0110520020	
38	DAMPER RING :4MM DIA.	080320410000	
39	STEPPED SCREW :NO.1 :9/64*10	512153020000	
40	BRACKET :LED LAMP	0L2310020000	
41	LAMP :NEEDLE BASE LED LIGHT[A]	0J7101700A00	
42	CLAMP :LED LAMP :L	0L231003L000	
43	CLAMP :LED LAMP :R	0L231003R000	
44			
45			
46			
47			
48			
49			
50			

Note: As for parts with mark @, please follow our instructions on Table of Contents in your parts order.

(U004)

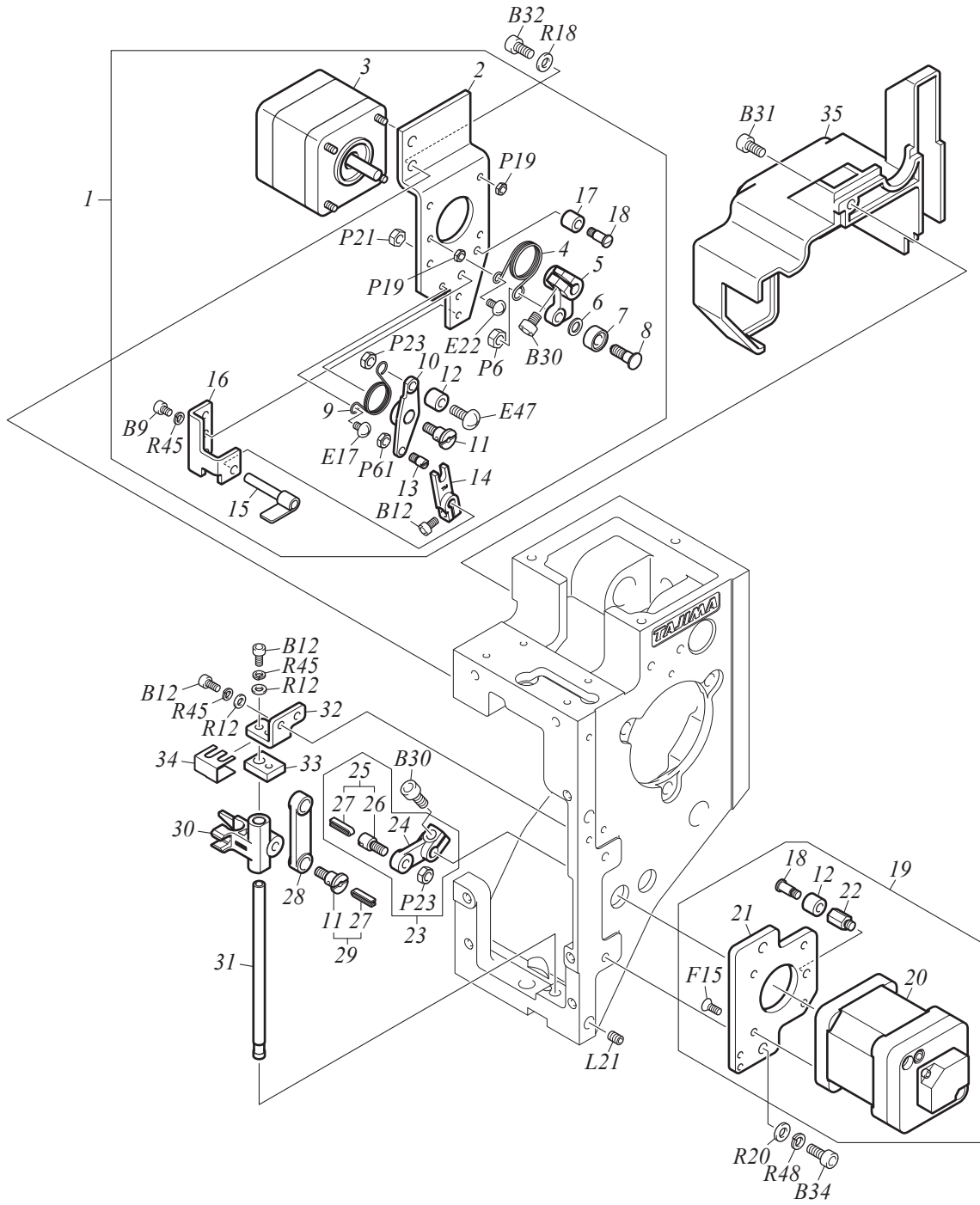

ARM 3

E1-5-3

No.	Part Name	Part No.	Remark
1	JUMP[A]	080320700A20	
2	BRACKET :JUMP MOTOR	080320640000	
3	PULSE MOTOR :42MM SQUARE :DOUBLE-END[T]	0J6110700T10	
4	TORSION SPRING :0.9MM DIA.	507309040020	
5	LEVER :JUMP	080320420010	
6	WASHER :4.8*8*T0.8	S301040801KC	
7	ROLLER :4.7MM DIA.	515110010010	
8	STEPPED SCREW :NO.1 :11/64*8.2	512154010010	
9	TORSION SPRING :0.7MM DIA.	507307060000	
10	LEVER :CLUTCH :MIDDLE	080320690000	
11	STEPPED SCREW :NO.2 :M4*12.5	512204050000	
12	DAMPER RING :4MM DIA.	080320410000	
13	SCREW WITH PIN :NO.1 :9/64-4	513153060010	
14	LEVER :CLUTCH :REVERSING	080320670000	
15	LEVER :CLUTCH :DRIVE[S]	080320610S00	
16	BASE :CLUTCH	080320650000	
17	STOPPER :JUMP CLUTCH	080320710000	
18	STEPPED SCREW :NO.1 :9/64*10	512153020000	
19	PRESSER FOOT MOTOR[A]	0J6110900A00	
20	PULSE MOTOR :42MM SQUARE 44L :WITH SENSOR[A]	0J6110000A00	
21	BASE :PRESSER FOOT MOTOR	080210640000	
22	STUD :NO.1 :M4-8.5	505104250000	
23	LEVER :PRESSER FOOT[S]	080230360S00	
24	LEVER :PRESSER FOOT	080230360000	
25	SCREW WITH PIN :NO.3 :M4-5.5[A]	513304060A00	
26	SCREW WITH PIN :NO.3 :M4-5.5	513304060000	
27	WICK :2.5*1*22	080240120010	
28	CONNECTING ROD :PRESSER FOOT	080230340000	
29	STEPPED SCREW :NO.2 :M4*12.5[A]	512204050A00	
30	PRESSER FOOT RECIPROCATOR	080210610000	
31	SHAFT :PRESSER FOOT DRIVE	080210630000	
32	SHAFT HOLDER :PRESSER FOOT DRIVE	080210620000	
33	FELT :PRESSER FOOT SHAFT	080240280000	
34	FELT PRESSER :PRESSER FOOT SHAFT	080240290000	
35	HEAD COVER :L	080430290000	
36			
37			
38			
39			
40			
41			
42			
43			
44			
45			
46			
47			
48			
49			
50			

Note: As for parts with mark @, please follow our instructions on Table of Contents in your parts order.

(U004)

NEEDLE BAR CASE 1

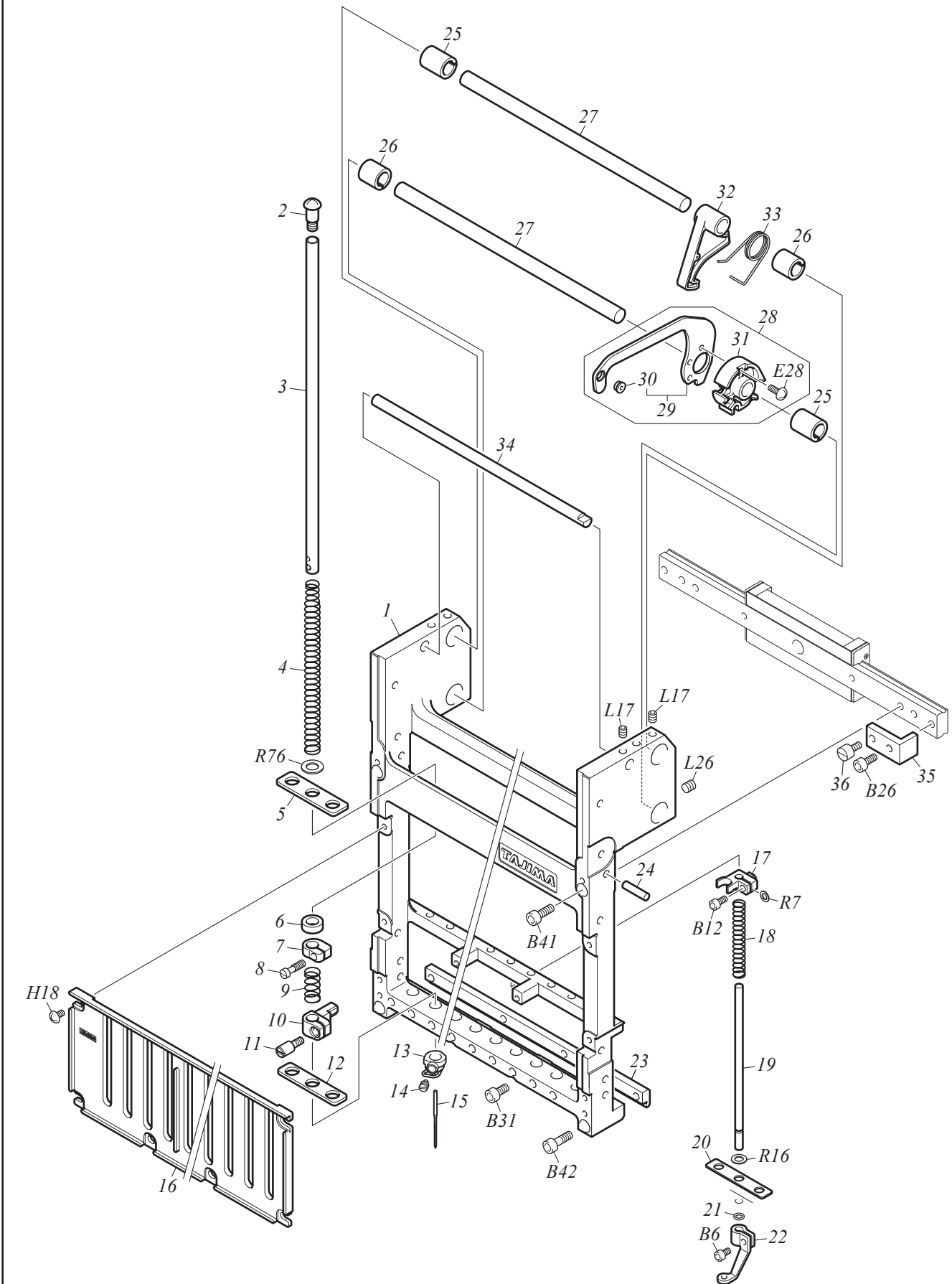

NEEDLE BAR CASE 1

E1-6-1

No.	Part Name	Part No.	Remark
1	NEEDLE BAR CASE	09012004@000	
2	SCREW :NEEDLE BAR	090410060010	
3	NEEDLE BAR	090410020010	
4	COMPRESSION SPRING :0.8MM DIA.	507608180000	
5	FELT PACKING	090430040000	
6	DAMPER RING :F	090430020010	
7	STOPPER :UPPER DEAD POINT	090420090000	
8	FLAT FILLISTER HEAD SCREW :9/64*10.5	511153030000	
9	COMPRESSION SPRING :0.5MM DIA.	507605190000	
10	NEEDLE BAR CONNECTING STUD	090420060010	
11	SCREW WITH PIN :NO.1 :9/64-8	513153080000	
12	FELT :NEEDLE BAR	090430180000	
13	NEEDLE CLAMP[S]	090420010S70	
14	SLOTTED HEAD SET SCREW :11/64*6B	511754010010	
15	NEEDLE :DB-K5Z1 #11	616500080000	
16	NEEDLE BAR GUIDE	0904501@@000	
17	PRESSER FOOT CONNECTING STUD	090420130000	
18	COMPRESSION SPRING :0.4MM DIA.	507604060000	
19	PRESSER FOOT SHAFT	090460530010	
20	FELT :PRESSER FOOT	090430190000	
21	O-RING :SO-3-90	612200230000	
22	PRESSER FOOT :2MM DIA./3MM DIA.	09046034@000	
23	RAIL :CASE :LOWER	09044007@010	
24	PARALLEL PIN :4*16-H7	611200050000	
25	SPLIT COLLAR :NO.1 :8MM DIA.	502308010010	
25	SPLIT COLLAR :NO.1 :8MM DIA.	502308020010	15-Needle
26	SPLIT COLLAR :NO.2 :8MM DIA.	502408020010	
26	SPLIT COLLAR :NO.2 :8MM DIA.	502408010020	15-Needle
27	GUIDE SHAFT :TAKE UP LEVER	09033001@000	
28	TAKE-UP LEVER[A]	090310050A40	
29	TAKE-UP LEVER[S]	090310050S40	
30	THREAD GUIDE COLLAR :2MM DIA.	516503020010	
31	BOSS :TAKE-UP LEVER	090310040010	
32	LEVER :STOPPER	090320010000	
33	TORSION SPRING :1MM DIA.	507310040010	
34	SPRING HOOK BAR	09033002@000	
35	STOPPER :LINEAR WAY	080260120000	
36	FLAT FILLISTER HEAD SCREW :M4*10	511104010010	
37			
38			
39			
40			
41			
42			
43			
44			
45			
46			
47			
48			

Note: As for parts with mark @, please follow our instructions on Table of Contents in your parts order.

(U004)

NEEDLE BAR CASE 2A (6-NEEDLE M/C)

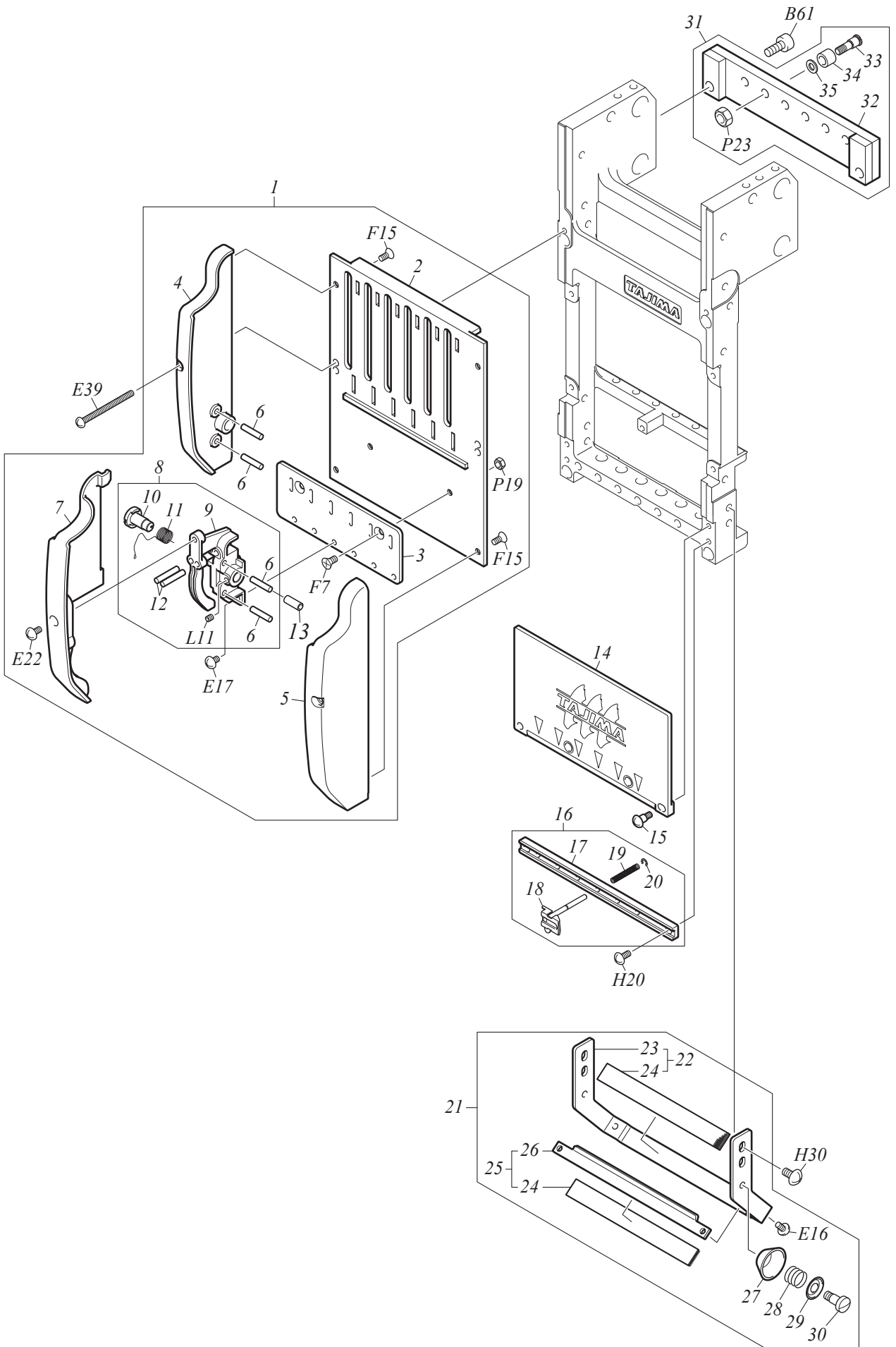

NEEDLE BAR CASE 2A (6-NEEDLE M/C)

E1-6-2a

No.	Part Name	Part No.	Remark
1	TOP COVER :06-15-NEEDLE[A]	09053021@A20	
2	TOP COVER	09053010@000	
3	MIDDLE THREAD GUIDE BASE	09021039@000	
4	SIDE COVER :L	09053019L000	
4	SIDE COVER :L :15-NEEDLE	09053020L000	
5	SIDE COVER :R	09053019R000	
5	SIDE COVER :R :15-NEEDLE	09053020R000	
6	STRAIGHT PIN :NO.1 :3MM DIA.	503101150020	
7	FRONT FACE COVER :MIDDLE THREAD GUIDE	090530120000	
8	BASE :MIDDLE THREAD GUIDE :0.4MM DIA.[A]	090210561A10	
8	BASE :MIDDLE THREAD GUIDE :0.5MM DIA.[A]	090210562A10	Thick Thread
9	BASE :MIDDLE THREAD GUIDE	090210400020	
10	SPRING SHAFT :THREAD TAKE-UP SPRING	090210410000	
11	THREAD TAKE-UP SPRING :NO.2 :0.4MM DIA.	507204030010	
11	THREAD TAKE-UP SPRING :NO.2 :0.5MM DIA.	507205030000	Thick Thread
12	STRAIGHT PIN :NO.1 :3MM DIA.*15.8	503101620000	
13	URETHANE TUBE :4MM DIA. :10L	090210440000	
14	FACE COVER :NEEDLE BAR CASE	09051018@010	
15	STEPPED SCREW :NO.1 :M3*9	512103120000	
16	UPPER THREAD LOCK[A]	08027005@A10	
17	BASE :UPPER THREAD LOCK	08027005@000	
18	LOCK SHAFT[S]	080270030S10	
19	COMPRESSION SPRING :0.3MM DIA.	507603040030	
20	E-RING :1.5MM DIA.	611100040000	
21	UPPER THREAD HOLDER[A]	0B020037@A00	
22	BASE :UPPER THREAD HOLDER[S]	0B020039@S00	
23	BASE :UPPER THREAD HOLDER	0B020039@000	
24	VELCRO	0B020038@000	
25	UPPER THREAD HOLDER[S]	0B020037@S00	
26	UPPER THREAD HOLDER	0B020037@000	
27	THREAD SUSPENDER DISK	0B0200050000	
28	COMPRESSION SPRING :0.3MM DIA.	507603020010	
29	PRESSER :THREAD SUSPENDER SPRING	0B0200060000	
30	STEPPED SCREW :NO.1 :9/64*7.5	512153040000	
31	BASE :CHANGE ROLLER :06-15-NEEDLE[A]	07011054@A00	
32	BASE :CHANGE ROLLER :06-15-NEEDLE[S]	07011054@S00	
33	STEPPED SCREW :NO.1 :M4*5.3	512104160020	
34	ROLLER :5*8*5	515105020010	
35	PLAIN WASHER :4*7.5*T0.8	519104060000	
36			
37			
38			
39			
40			
41			
42			
43			
44			
45			
46			

Note: As for parts with mark @, please follow our instructions on Table of Contents in your parts order.

(U004)

NEEDLE BAR CASE 2B (12, 15-NEEDLE M/C)

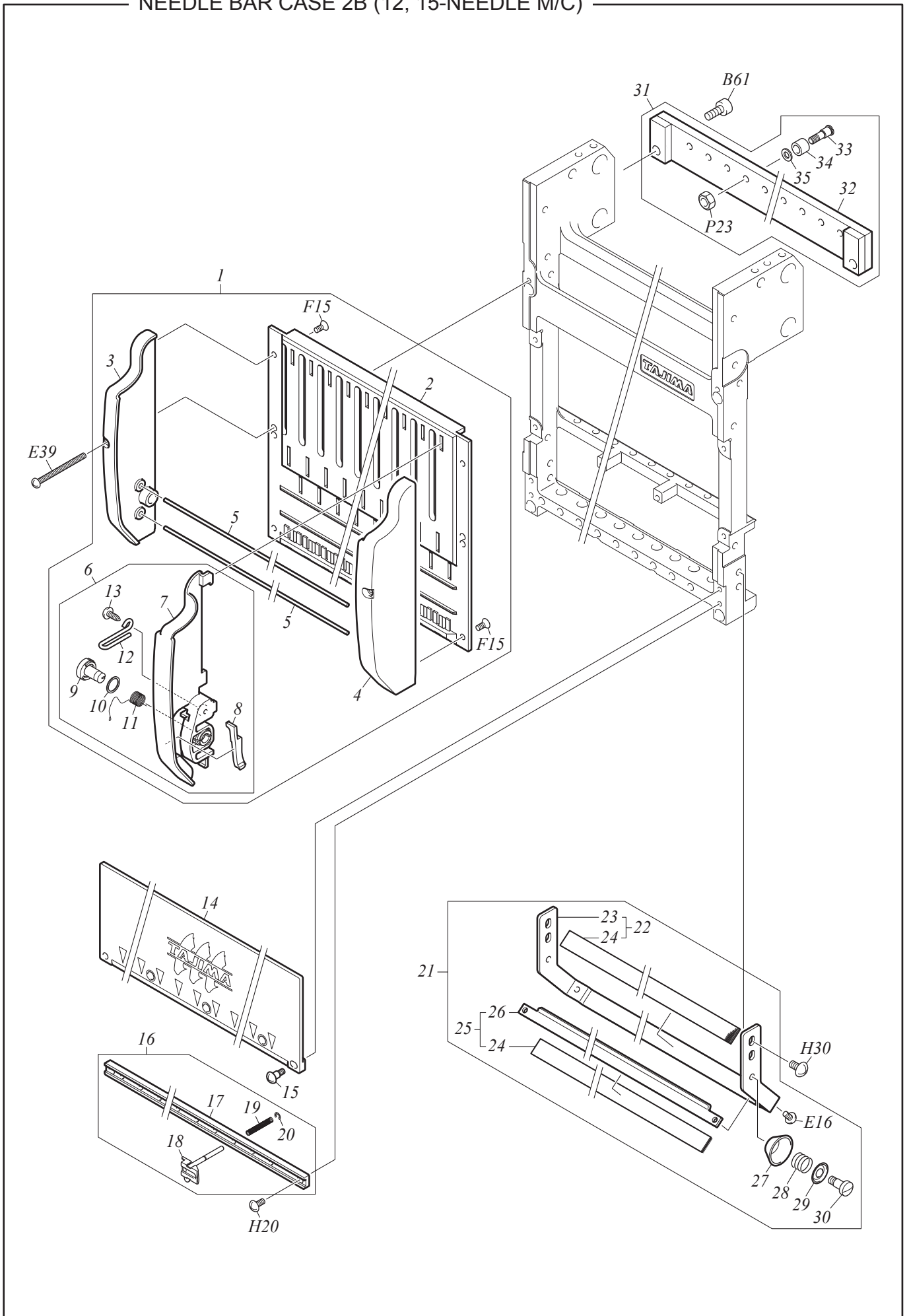

NEEDLE BAR CASE 2B (12, 15-NEEDLE M/C)

E1-6-2b

No.	Part Name	Part No.	Remark
1	TOP COVER[A]	09053023@A00	
2	TOP COVER	09053023@000	
3	SIDE COVER :L	09053019L000	
3	SIDE COVER :L :15-NEEDLE	09053020L000	
4	SIDE COVER :R	09053019R000	
4	SIDE COVER :R :15-NEEDLE	09053020R000	
5	STRAIGHT PIN :2MM DIA.	09021054@000	
6	BASE :MIDDLE THREAD GUIDE :0.4MM DIA.[A]	090210511A00	
6	BASE :MIDDLE THREAD GUIDE :0.5MM DIA.[A]	090210512A00	Thick Thread
7	BASE :MIDDLE THREAD GUIDE	090210510000	
8	SIDE WALL PLATE :MIDDLE THREAD GUIDE	090210500000	
9	SPRING SHAFT :THREAD TAKE-UP SPRING	090210520000	
10	PLAIN WASHER :8*10*T0.5	519108110000	
11	THREAD TAKE-UP SPRING :NO.2 :0.4MM DIA.	507204030010	
11	THREAD TAKE-UP SPRING :NO.2 :0.5MM DIA.	507205030000	Thick Thread
12	LARGE THREAD HOLDER	090210530000	
13	TRUSS HEAD TAPPING SCREW :3P*12	S530031201SD	
14	FACE COVER :NEEDLE BAR CASE	09051018@010	
15	STEPPED SCREW :NO.1 :M3*9	512103120000	
16	UPPER THREAD LOCK[A]	08027005@A10	
17	BASE :UPPER THREAD LOCK	08027005@000	
18	LOCK SHAFT[S]	080270030S10	
19	COMPRESSION SPRING :0.3MM DIA.	507603040030	
20	E-RING :1.5MM DIA.	611100040000	
21	UPPER THREAD HOLDER[A]	0B020037@A00	
22	BASE :UPPER THREAD HOLDER[S]	0B020039@S00	
23	BASE :UPPER THREAD HOLDER	0B020039@000	
24	VELCRO	0B020038@000	
25	UPPER THREAD HOLDER[S]	0B020037@S00	
26	UPPER THREAD HOLDER	0B020037@000	
27	THREAD SUSPENDER DISK	0B0200050000	
28	COMPRESSION SPRING :0.3MM DIA.	507603020010	
29	PRESSER :THREAD SUSPENDER SPRING	0B0200060000	
30	STEPPED SCREW :NO.1 :9/64*7.5	512153040000	
31	BASE :CHANGE ROLLER :06-15-NEEDLE[A]	07011054@A00	
32	BASE :CHANGE ROLLER :06-15-NEEDLE[S]	07011054@S00	
33	STEPPED SCREW :NO.1 :M4*5.3	512104160020	
34	ROLLER :5*8*5	515105020010	
35	PLAIN WASHER :4*7.5*T0.8	519104060000	
36			
37			
38			
39			
40			
41			
42			
43			
44			
45			
46			

Note: As for parts with mark @, please follow our instructions on Table of Contents in your parts order.

(U004)

X-AXIS DRIVE SYSTEM

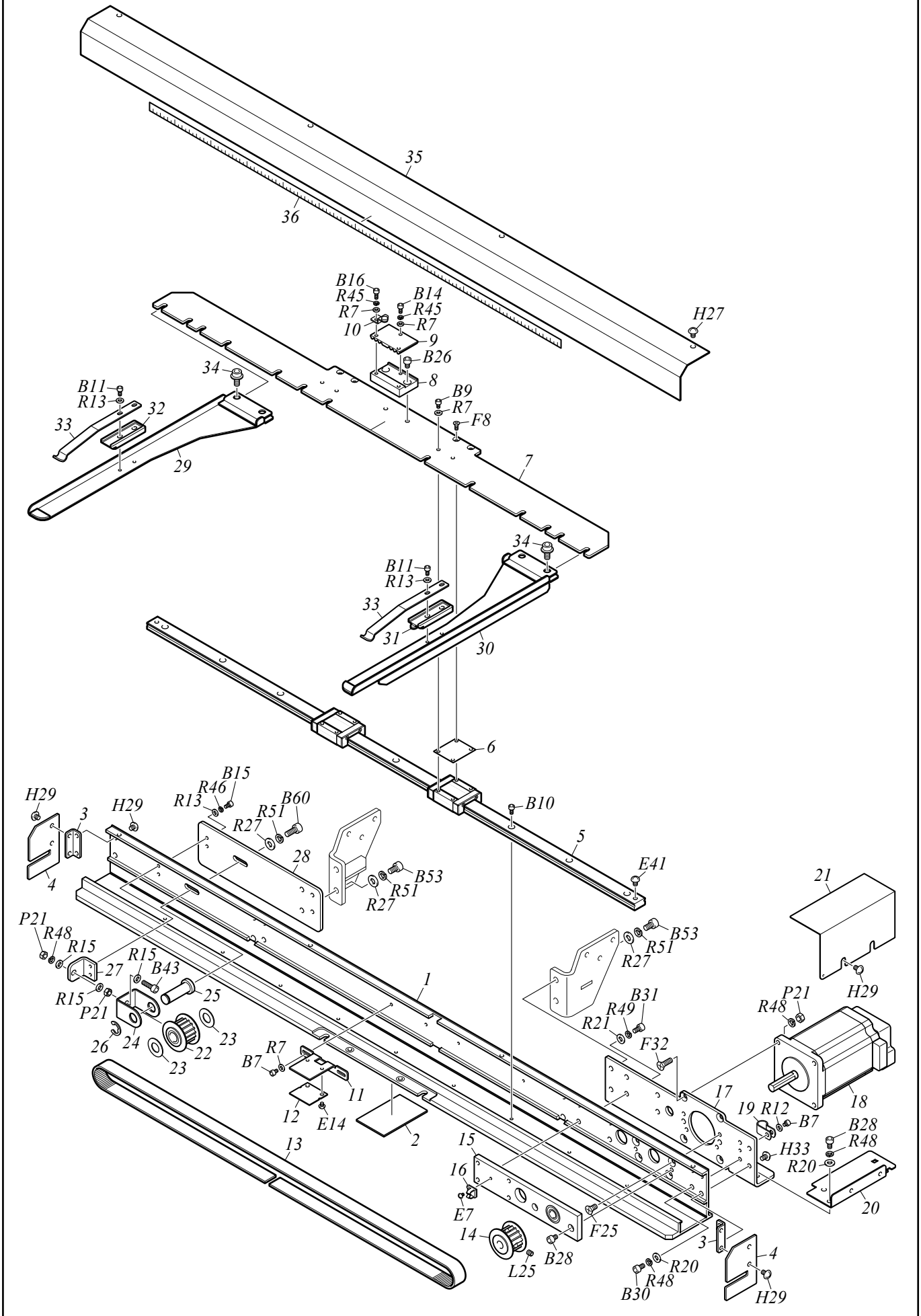

X-AXIS DRIVE SYSTEM

E1-7

No.	Part Name	Part No.	Remark
1	Z-SPEC. FRAME :0001/500S[S]	0F4110500S00	
2	FELT :T1.9[S]	0G0140040S00	
3	BRACKET :Z-SPEC. FRAME SASH COVER	0F5300350000	
4	COVER :Z-SPEC. FRAME SASH	0F4160640000	
5	LINEAR WAY :X DRIVE SYSTEM	660300110001	
6	SPACER :NO.2 :T0.3	510200300000	
7	FRAME HOLDER[S]	0F5300340S10	
8	BELT CATCHER :NO.1 :X	0F4160480000	
9	BELT CATCHER :NO.2 :X	0F4160490000	
10	SENSOR PLATE :NO.1[S]	0F4140080S00	
11	BRACKET :MAGNETIC SENSOR	0F4140020000	
12	CARD :MAGNETIC SENSOR A	0J4204400000	
13	TIMING BELT :MA5 :W15-270E/LY	623A00080000	
14	TIMING PULLEY :W15-16	501430140020	
15	BEARING CASE :NO.4 :B :8MM DIA.[S]	0F4150350S00	
16	MINI CLAMP :MB-2	644100080000	
17	BRACKET :X MOTOR :B	0F4150320000	
18	PULSE MOTOR :60MM SQUARE :WITH SENSOR[A]	0J6105400A10	
19	CLAMP :5N	644500050000	
20	STAY :HARNESS COVER :B	0F4150330000	
21	COVER :X MOTOR HARNESS :B	0F4150340000	
22	TIMING PULLEY :W15-16[S]	501430060S10	
23	PLASTIC WASHER :10.2*15*T0.5	519212030000	
24	HOLDER :TIMING PULLEY	0F4160040000	
25	FLANGE PIN :NO.3	503503030000	
26	E-RING :7MM DIA.	611100100000	
27	TENSIONER :X DRIVE BELT	0F4160050010	
28	REINFORCING PLATE :Z-SPEC. FRAME :B	0F4160650000	
29	FRAME HOLDER :L[S]	0G314004LS40	
30	FRAME HOLDER :R[S]	0G314004RS40	
31	STOPPER :NO.1	0G314001A020	
32	STOPPER :NO.2	0G314002B020	
33	PLATE SPRING :HOLDER BASE :T1.5	507815060010	
34	HEXAGON SOCKET HEAD FLANGE SCREW :M5*10	S123051001MZ	
35	COVER :Z-SPEC. FRAME :0001/500S	0F4110480000	
36	TRAVERSE SCALE	0P1200020000	
37			
38			
39			
40			
41			
42			
43			
44			
45			
46			
47			
48			
49			
50			

Note: As for parts with mark @, please follow our instructions on Table of Contents in your parts order.

(U004)

Y-AXIS DRIVE SYSTEM

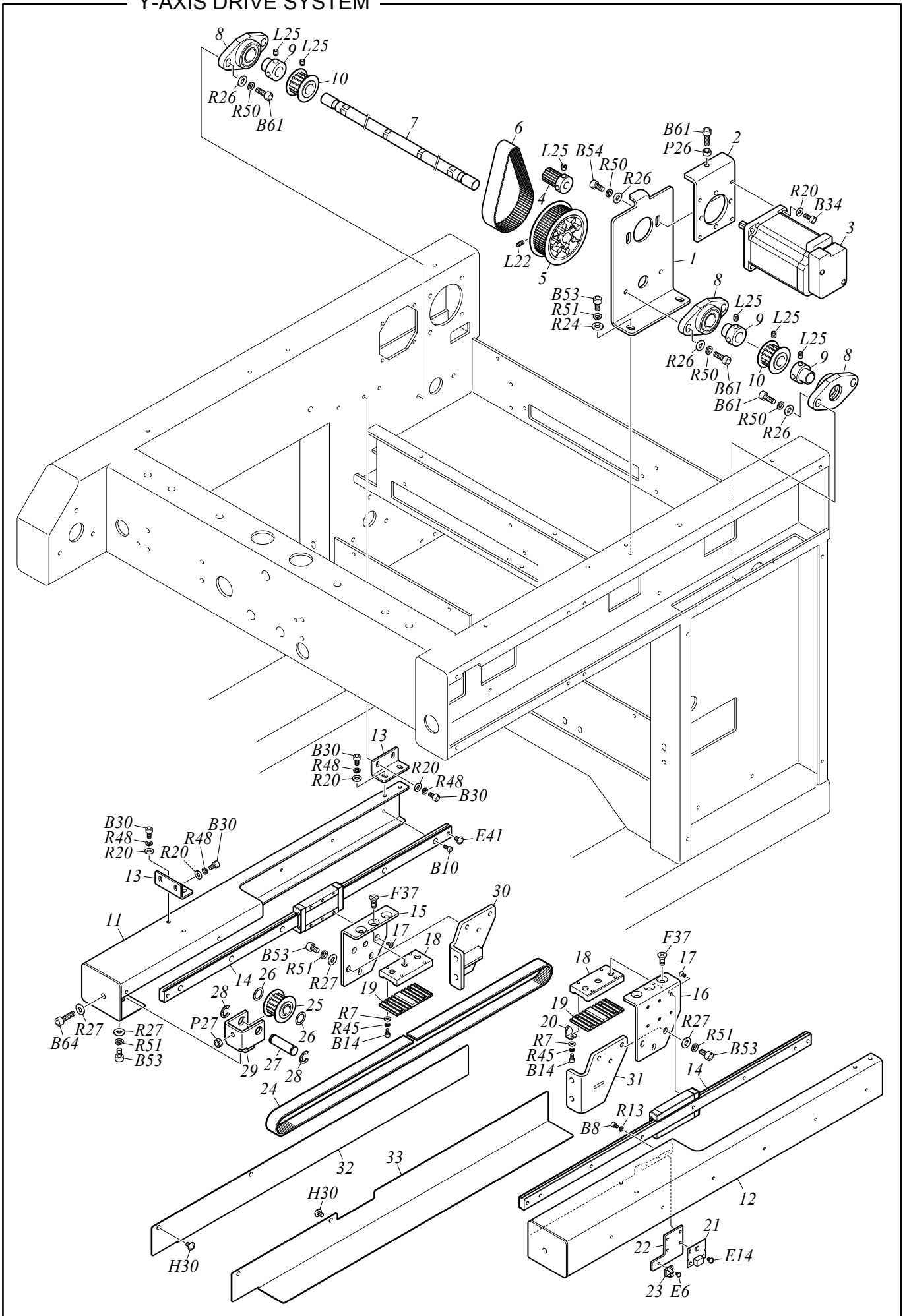

Y-AXIS DRIVE SYSTEM

E1-8

No.	Part Name	Part No.	Remark
1	BRACKET :Y MOTOR	0F4240100000	
2	BASE :Y MOTOR	0F4240010000	
3	PULSE MOTOR :60MM SQUARE :WITH SENSOR[A]	0J6105400A10	
4	TIMING PULLEY :W19-18	501F18020000	
5	TIMING PULLEY :W20-63	501F17010000	
6	TIMING BELT :3GT :19*270/E	628300010001	
7	Y SHAFT :12P*500	QE1103010000	
8	BEARING CASE :NO.3 :15MM DIA.[S]	508315030S00	
9	BEARING COLLAR :12MM DIA.	502712020000	
10	TIMING PULLEY :W15-16	501430020020	
11	BASE :LINEAR WAY :L	0F423072@000	
12	BASE :LINEAR WAY :R	0F423073@000	
13	BRACKET :LINEAR BASE	0F4220090000	
14	LINEAR WAY :L450	660400000001	
15	DRIVE ARM :Z-SPEC. FRAME :L	0F423062L000	
16	DRIVE ARM :Z-SPEC. FRAME :R	0F423062R000	
17	COUNTERSUNK HEAD SCREW :M3*6	511403010000	
18	BELT CATCHER :NO.1	0F4230630000	
19	BELT CATCHER :NO.2	0F4230640000	
20	SENSOR PLATE :NO.1[S]	0F4230670S00	
21	CARD :MAGNETIC SENSOR A	0J4204400000	
22	BRACKET :ORIGIN SENSOR	0F4230660000	
23	MINI CLAMP :MB-2	644100080000	
24	TIMING BELT :MA5 :W15-230E/LY	623A00060000	
25	TIMING PULLEY :W15-16[S]	501430060S10	
26	PLASTIC WASHER :10.2*15*T0.5	519212030000	
27	STRAIGHT PIN :NO.4 :10MM DIA.	503104240000	
28	E-RING :7MM DIA.	611100100000	
29	HOLDER :TENSION PULLEY	0F4210060000	
30	BRACKET :DRIVE ARM	0F4230650000	
31	BRACKET :DRIVE ARM :R	0F4230690000	
32	COVER :LINEAR WAY :L	0F423074L000	
33	COVER :LINEAR WAY :R	0F423074R000	
34			
35			
36			
37			
38			
39			
40			
41			
42			
43			
44			
45			
46			
47			
48			
49			
50			

Note: As for parts with mark @, please follow our instructions on Table of Contents in your parts order.

(U004)

TENSION BASE

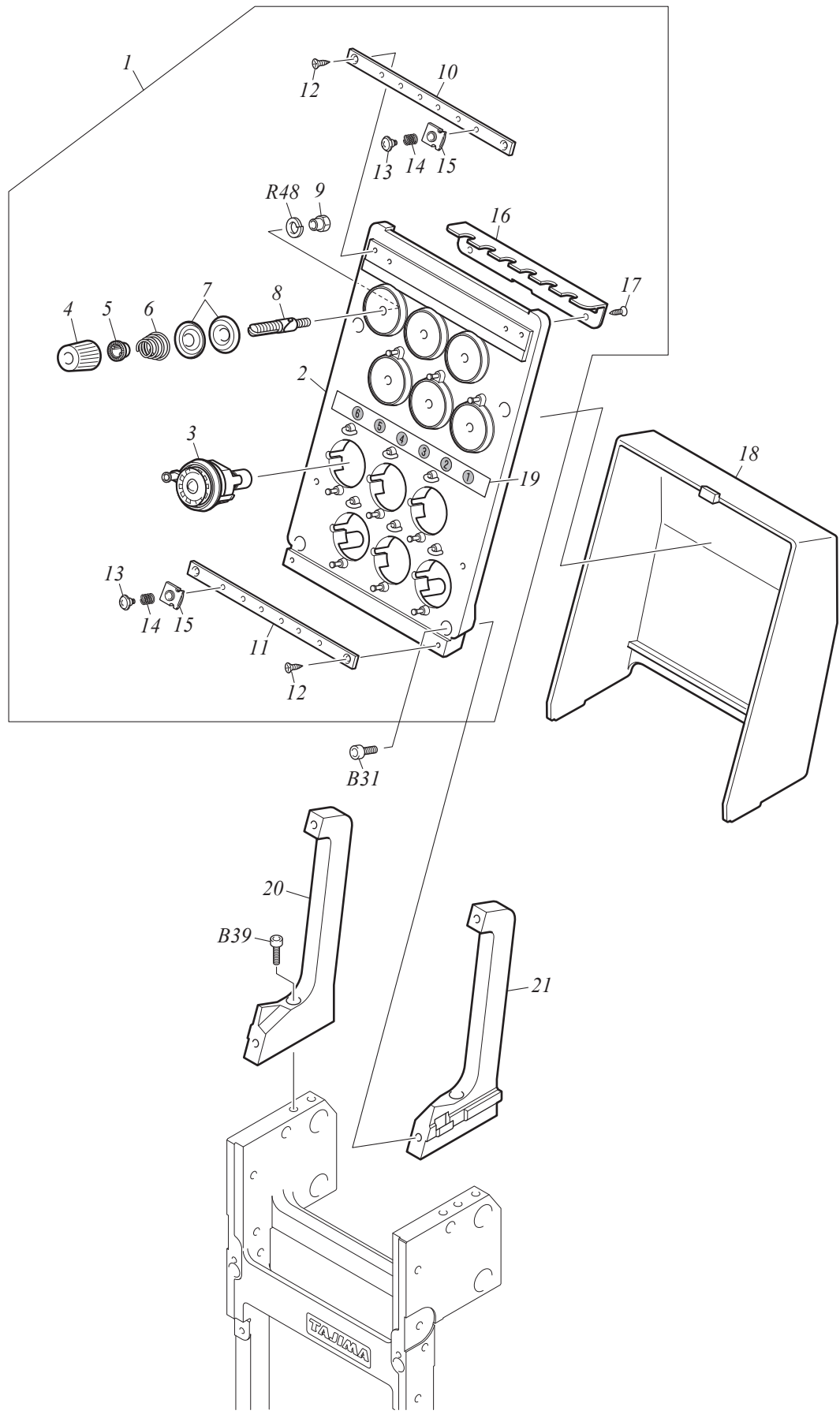

TENSION BASE

E1-9

No.	Part Name	Part No.	Remark
1	TENSION BASE :06-15-NEEDLE[A]	0C016003@A10	
2	TENSION BASE :ROTARY	0C012001@040	
3	ROTARY TENSION DISK[A]	0C0230320A00	
4	KNOB :THREAD TENSION :A	0C0220150000	
5	SPRING HOOK	0C0220080000	
6	TAPER SPRING :0.6MM DIA.	507706010000	
7	TENSION DISK	0C0210060000	
8	THREAD TENSION STUD :WITH GROOVE	0C0210040000	
9	SCREW BUSHING :NO.2 :M4	509804050000	
10	BASE :THREAD PRESSER :U :06-NEEDLE	0C0220316000	
10	BASE :THREAD PRESSER :U :12-NEEDLE	0C022035Y000	
10	BASE :THREAD PRESSER :U :15-NEEDLE	0C022037X000	
11	BASE :THREAD PRESSER :D :06-NEEDLE	0C0220326000	
11	BASE :THREAD PRESSER :D :12-NEEDLE	0C022036Y000	
11	BASE :THREAD PRESSER :D :15-NEEDLE	0C022038X000	
12	COUNTERSUNK TAPPING SCREW :3P*10	S550031001SD	
13	TRUSS HEAD SCREW :STEPPED :M3*4*2	S132030401TD	
14	COMPRESSION SPRING :0.2MM DIA.	507602010000	
15	THREAD PRESSER	0C0220400000	
16	UPPER THREAD GUIDE :TENSION BASE	0C022017@020	
17	COUNTERSUNK TAPPING SCREW :3P*8	S550030801SD	
18	COVER :TENSION BASE	0C015006@000	
19	LABEL :NEEDLE BAR NO.	0P140002@000	
20	BRACKET :TENSION BASE :L[S]	0C024003LS00	
21	BRACKET :TENSION BASE :R[S]	0C024003RS00	
22			
23			
24			
25			
26			
27			
28			
29			
30			
31			
32			
33			
34			
35			
36			
37			
38			
39			
40			
41			
42			
43			
44			
45			
46			

Note: As for parts with mark @, please follow our instructions on Table of Contents in your parts order.

(U004)

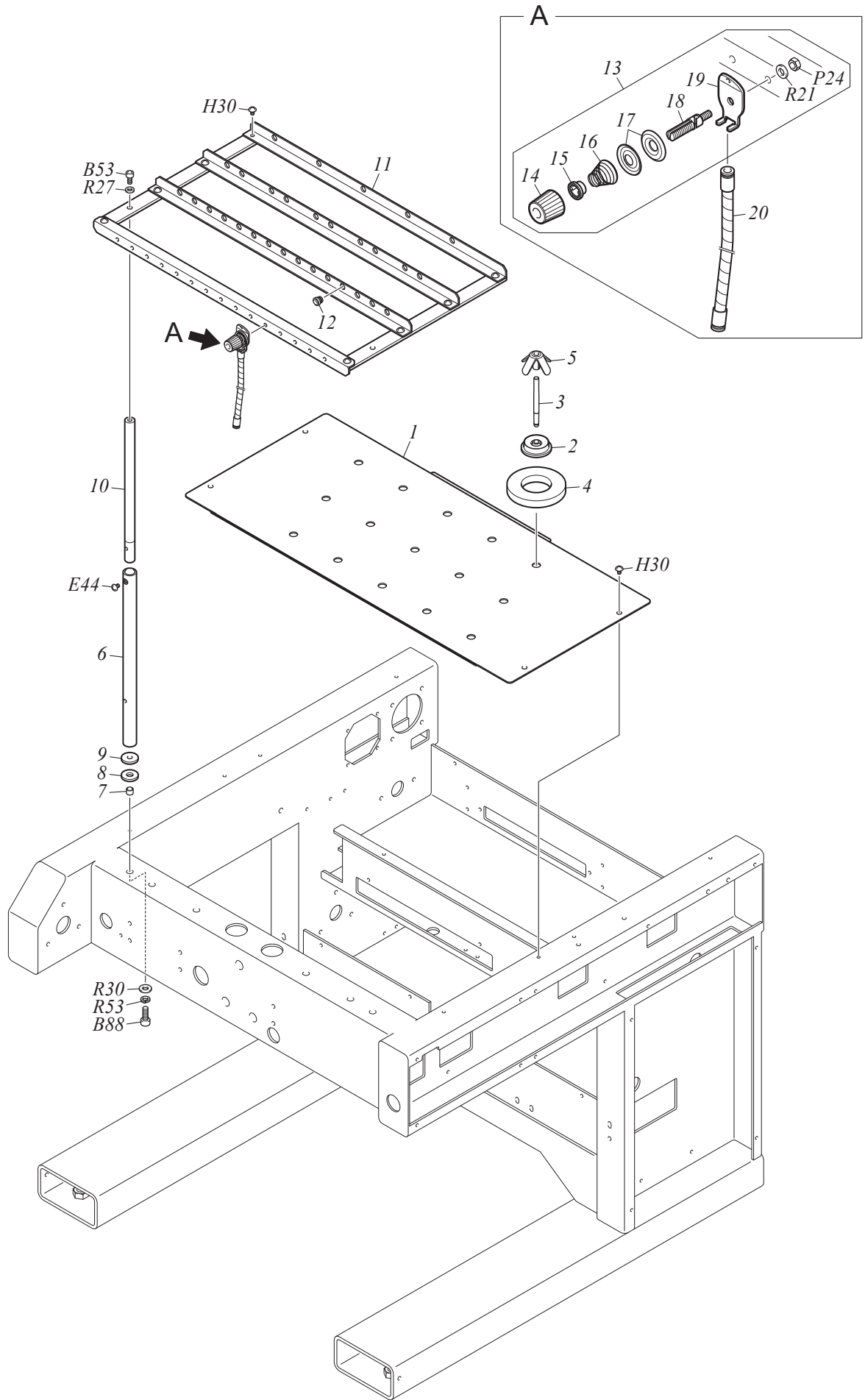

THREAD STAND

E1-10

No.	Part Name	Part No.	Remark
1	THREAD STAND PLATE[S]	1DL1010@@S10	
2	BASE :THREAD STAND STUD	0D0110420000	
3	THREAD STAND STUD	0D0110410000	
4	THREAD STAND RING :T10	0D0110022010	
5	THREAD STAND BLADE	0D0110010010	
6	THREAD COURSE SUPPORT BAR :A	0D0210490000	
7	COLLAR :NO.1 :6MM DIA.	502506060000	
8	RUBBER WASHER :8*20*t3	519208050000	
9	PLAIN WASHER :6*20*t3	519106170000	
10	THREAD COURSE SUPPORT BAR :B	0D0210470010	
11	THREAD COURSE	1ED10101@000	
12	THREAD GUIDE COLLAR :BLACK :4.5MM DIA.	516501012010	
12	THREAD GUIDE COLLAR :RED :4.5MM DIA.	516501011010	
13	THREAD TENSION :TUBE :B	UD1100000200	
14	KNOB :THREAD TENSION :A	0C0220150000	
15	SPRING HOOK	0C0220080000	
16	TAPER SPRING :0.6MM DIA.	507706010000	
17	TENSION DISK	0C0220160010	
18	THREAD TENSION STUD :WITH GROOVE	0C0210040000	
19	THREAD TENSION GUIDE :TUBE	0D0210150030	
20	SPIRAL TUBE :L230[A]	0D0210052A00	
21			
22			
23			
24			
25			
26			
27			
28			
29			
30			
31			
32			
33			
34			
35			
36			
37			
38			
39			
40			
41			
42			
43			
44			
45			
46			
47			
48			
49			

Note: As for parts with mark @, please follow our instructions on Table of Contents in your parts order.

(U004)

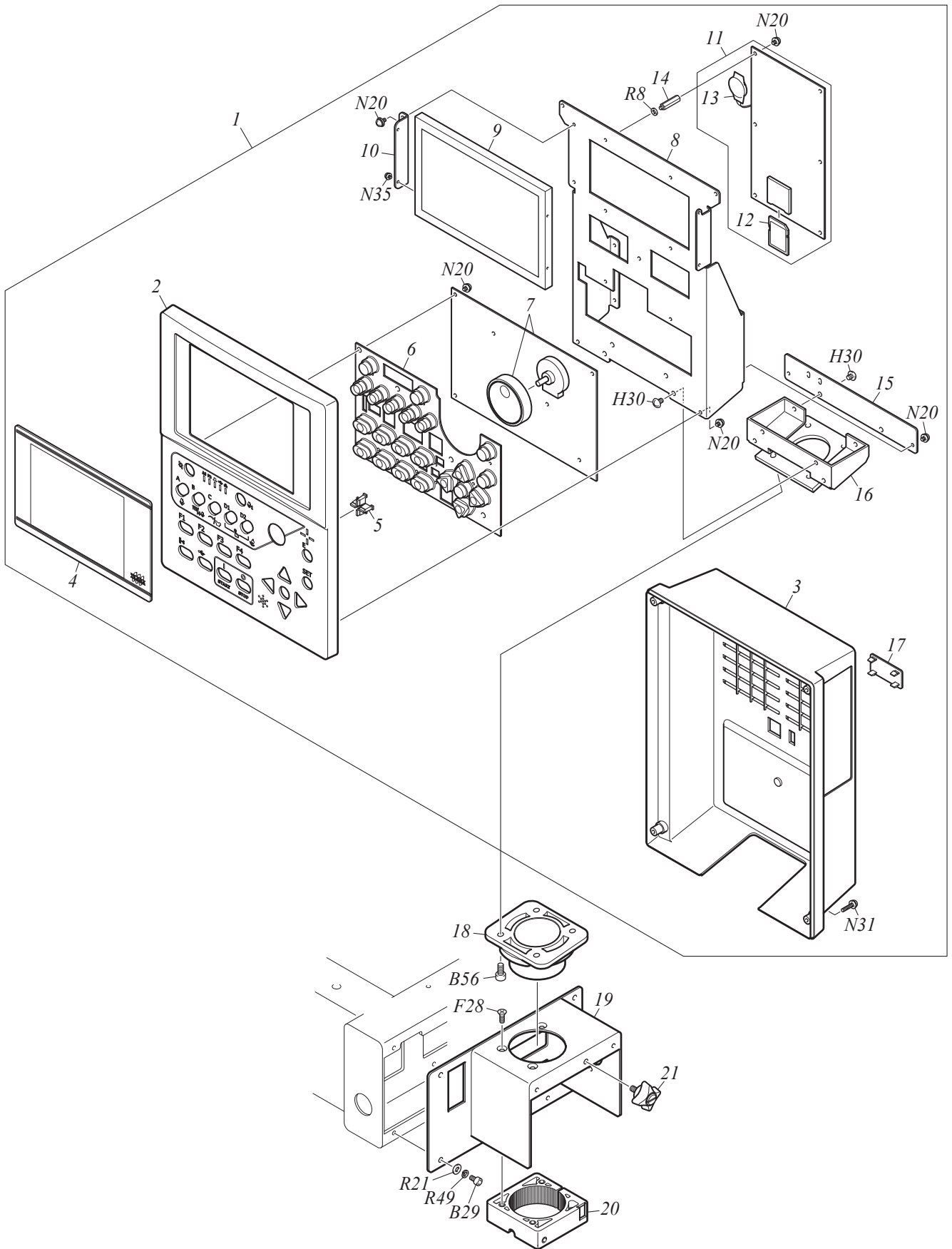

OPERATION PANEL

E1-11

No.	Part Name	Part No.	Remark
1	CONTROLLER :XC1[A]	0J0204700A00	
2	OPERATION PANEL :FRONT[S]	0J1414800S00	
3	OPERATION PANEL :REAR[S]	0J1411700S00	
4	COVER :LCD PANEL	0J1414900000	
5	COVER :LAMP	0J1404700000	
6	OPERATION BUTTON	0J1404500000	
7	CARD :SWITCH :XC1	0J3504400000	
8	BASE :PANEL CARD	0J1415000000	
9	LCD :7 INCH WIDE	641200250000	
10	BRACKET :LCD	0J1415100000	
11	CARD :CPU :XC1[A]	0J2306300A00	
12	SD CARD :XC1	0J2402600000	
13	LITHIUM BATTERY :XC[A]	645300490A01	
14	SPACER :HEXAGON :L20 :M3 :UNDER HEAD 3MM	644501750000	
15	SUPPORT :PANEL BASE	0J1406600020	
16	BASE :OPERATION PANEL[S]	0J1405000S00	
17	BLIND LID :USB	0J1409200000	
18	HOLDER :OPERATION PANEL	030221040000	
19	BASE :OPERATION PANEL	03022105@000	
20	CLAMP :CONTROLLER HOLDER[S]	030220870S00	
21	KNOBBED SCREW :NO.2 :M5*9[S]	511F05120S00	
22			
23			
24			
25			
26			
27			
28			
29			
30			
31			
32			
33			
34			
35			
36			
37			
38			
39			
40			
41			
42			
43			
44			
45			
46			
47			
48			
49			
50			

Note: As for parts with mark @, please follow our instructions on Table of Contents in your parts order.

(U004)

ELECTRICAL PARTS

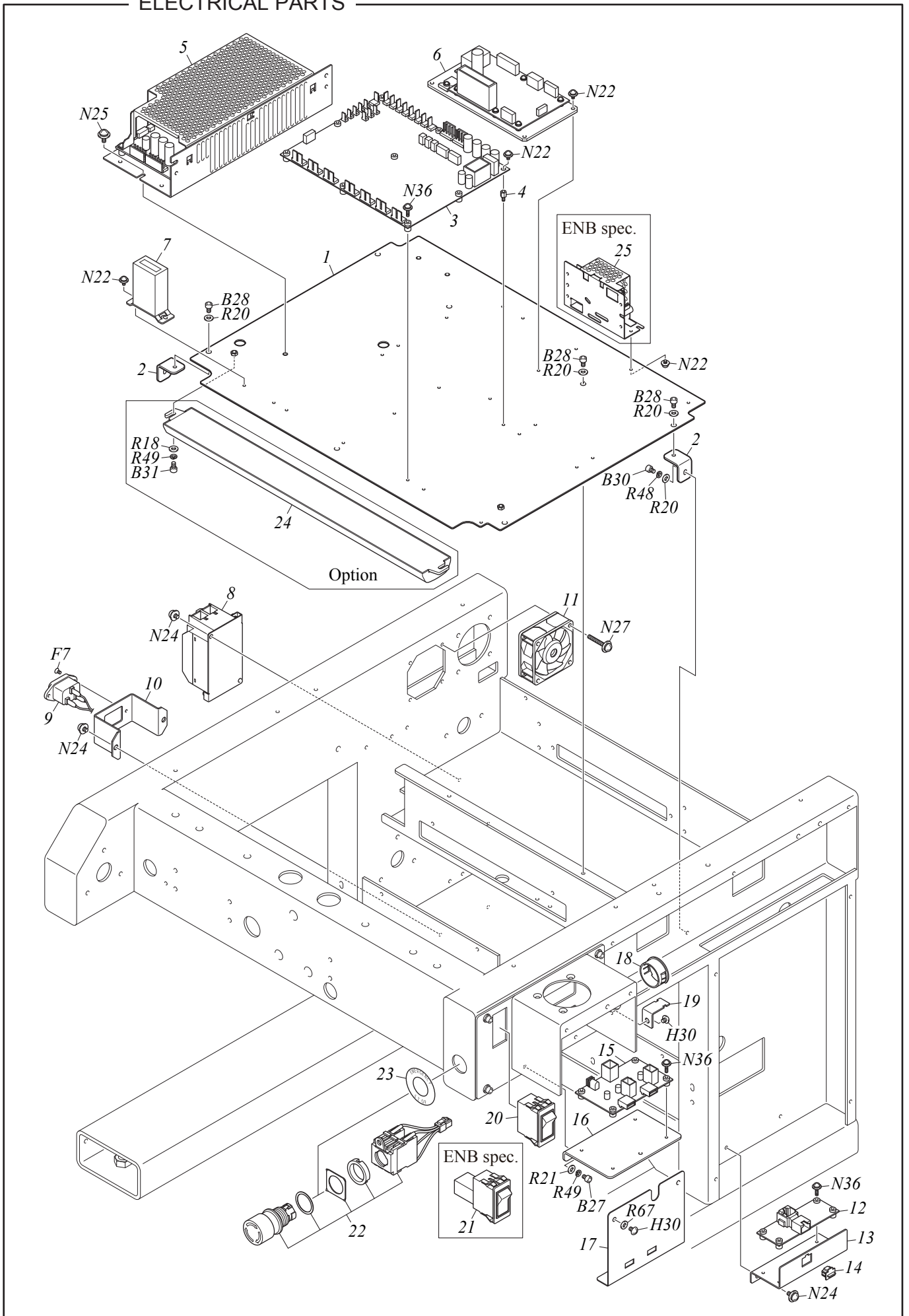

ELECTRICAL PARTS

E1-12

No.	Part Name	Part No.	Remark
1	BASE :ELECTRICAL COMPONENT	030190660010	
2	BRACKET :ELECTRICAL COMPONENT BASE	030110360000	
3	CARD :CONTROL	0J2206900000	
4	SPACER :HEXAGON :L6 :M3	644500890000	
5	DC POWER SUPPLY :24V :350W	645300500000	
6	MAIN SHAFT DRIVER :X14 :200[A]	0J0305000A10	
7	COUNTER :ELECTRO-MAGNETIC	0J4500200010	
8	NOISE FILTER :SINGLE-PHASE :10A	641400250000	
9	AC INLET	643500220000	
10	BASE INLET	030190600000	
11	MOTOR :FAN :60MM SQUARE	0J6500700000	
12	CARD :CONNECTOR :A	0J2503800000	
13	BRACKET :CONNECTOR CARD	03019067@000	
14	DUST CAP :LAN	644501460000	
15	CARD :USB HUB :B	0J2503701000	
16	BRACKET :USB CARD	03022102@000	
17	COVER :BASE	03022103@000	
18	BUSHING :HARNESS	0J1501100020	
19	STAY :WIRING	0F4160360010	
20	CIRCUIT PROTECTOR :SINGLE-PHASE 10A	646100310000	
21	CIRCUIT PROTECTOR :SINGLE-PHASE 10A[A]	646100310A00	
22	SWITCH :EMERGENCY STOP	0J0607500A00	
22	SWITCH :EMERGENCY STOP :CE	646100350000	ENB spec.
23	NAME PLATE :EMERGENCY STOP SWITCH	0J5108800000	
24	LAMP :LED LIGHT :16W	0J7101800000	
25	DC POWER SUPPLY :5V :10W	645300560000	
26			
27			
28			
29			
30			
31			
32			
33			
34			
35			
36			
37			
38			
39			
40			
41			
42			
43			
44			
45			
46			
47			
48			
49			

Note: As for parts with mark @, please follow our instructions on Table of Contents in your parts order.

(U004)

TABLE, BORDER FRAME (OPTION)

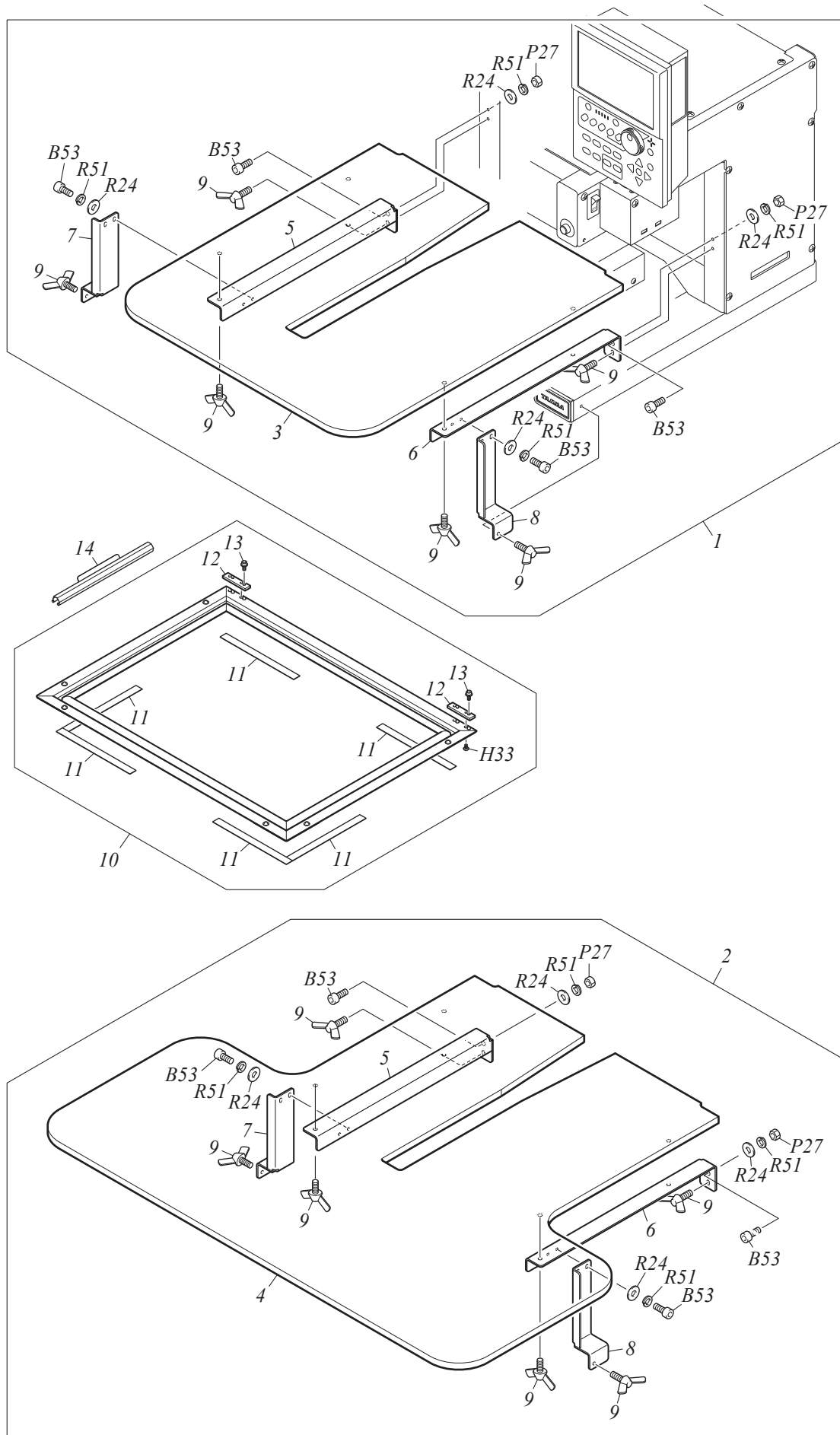

TABLE, BORDER FRAME (OPTION)

E1-13

No.	Part Name	Part No.	Remark
1	TABLE :TUBULAR GOODS FRAME[T]	0L3120140T20	
2	TABLE :BORDER FRAME[T]	0L3120090T30	
3	TABLE	0L3120140010	Tubular Goods Frame
4	TABLE :BORDER FRAME	0L3120090020	
5	BASE :TABLE SUPPORT :L	0L312011L010	
6	BASE :TABLE SUPPORT :R	0L312011R010	
7	SUPPORT :TABLE :L	0L312012L010	
8	SUPPORT :TABLE :R	0L312012R010	
9	WING BOLT :TYPE 2 :M5*10	S180051001SD	
10	BORDER FRAME :0001/036*500S[A]	303150030A00	
11	FELT :15*1.3*180[S]	0G0240220S00	
12	SPACER :BORDER FRAME	0G0250150010	
13	HEXAGON SOCKET HEAD FLANGE SCREW :M5*8	S123050801MZ	
14	BORDER FRAME CLIP :BFF8 :L100-300[S]	0G052021@S00	
15			
16			
17			
18			
19			
20			
21			
22			
23			
24			
25			
26			
27			
28			
29			
30			
31			
32			
33			
34			
35			
36			
37			
38			
39			
40			
41			
42			
43			
44			
45			
46			
47			
48			
49			
50			

Note: As for parts with mark @, please follow our instructions on Table of Contents in your parts order.

(U004)

SIGNAL TOWER, STAND (OPTION)

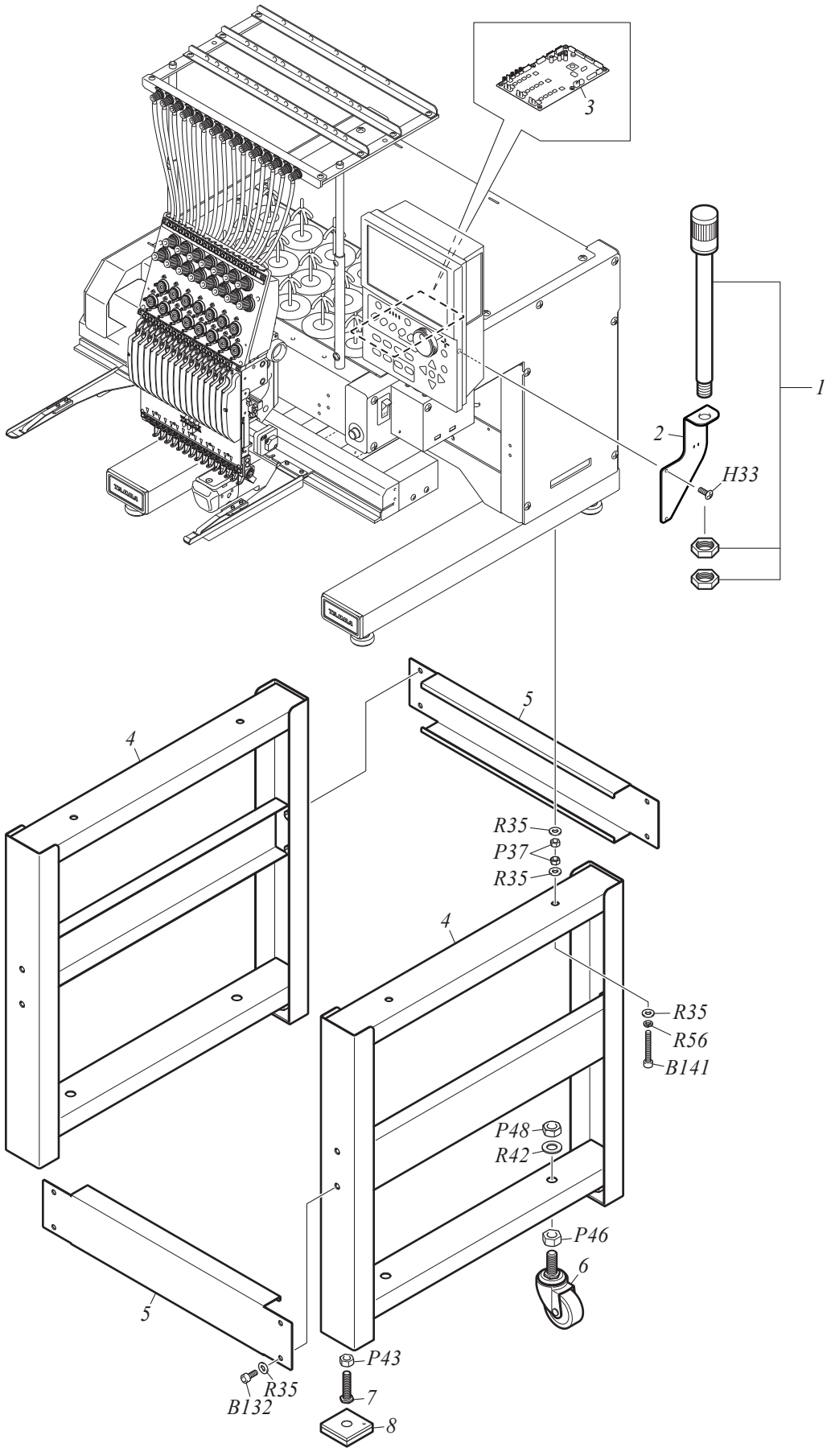

SIGNAL TOWER, STAND (OPTION)

E1-14

No.	Part Name	Part No.	Remark
1	LAMP :SIGNAL TOWER :LED ROTATING LIGHT	0J7102000000	
2	BRACKET :SIGNAL TOWER	0L3190140000	
3	CARD :OPTION	0J2207300000	
4	STAND STAND	0L311021@000	
5	JOINT :STAND STAND	0L311022@000	
6	CASTER :ST-65RH M16*40	614300210000	
7	LEVELING BOLT :M12*50	030530040000	
8	VIBRATION-PREVENTIVE BASE[S]	03052004@S00	
9			
10			
11			
12			
13			
14			
15			
16			
17			
18			
19			
20			
21			
22			
23			
24			
25			
26			
27			
28			
29			
30			
31			
32			
33			
34			
35			
36			
37			
38			
39			
40			
41			
42			
43			
44			
45			
46			
47			
48			
49			
50			

Note: As for parts with mark @, please follow our instructions on Table of Contents in your parts order.

(U004)

POSITION MARKER (OPTION)

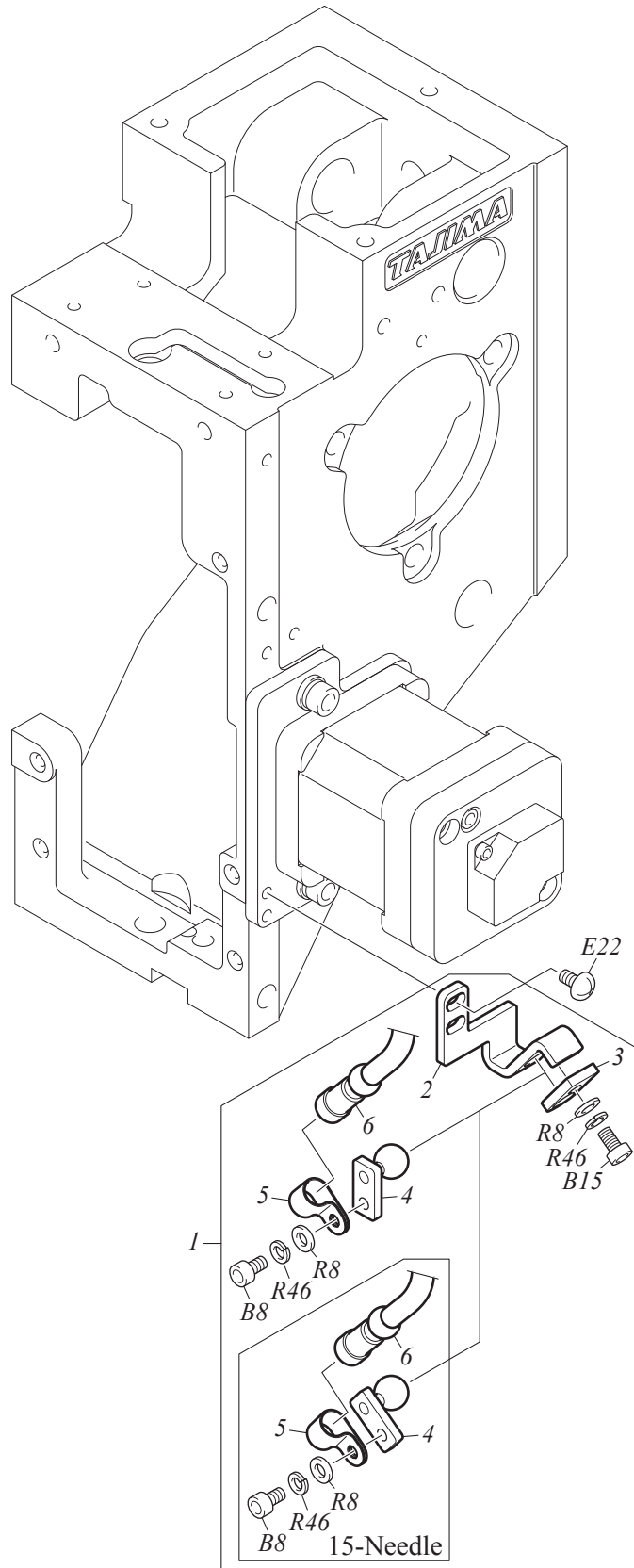

POSITION MARKER (OPTION)

E1-15

No.	Part Name	Part No.	Remark
1	POSITION MARKER[T]	0L2300290T00	
2	BASE :POSITION MARKER	0L2300240000	
3	HOLDER :BRACKET	0L2300250000	
4	BRACKET :POSITION MARKER[S]	0L2300280S00	
5	CLIP :MARKER	0L2300190000	
6	POSITION MARKER[A]	0J7100200A20	
7			
8			
9			
10			
11			
12			
13			
14			
15			
16			
17			
18			
19			
20			
21			
22			
23			
24			
25			
26			
27			
28			
29			
30			
31			
32			
33			
34			
35			
36			
37			
38			
39			
40			
41			
42			
43			
44			
45			
46			
47			
48			
49			
50			

Note: As for parts with mark @, please follow our instructions on Table of Contents in your parts order.

(U004)

X-EXTENSION UNIT 1 (OPTION)

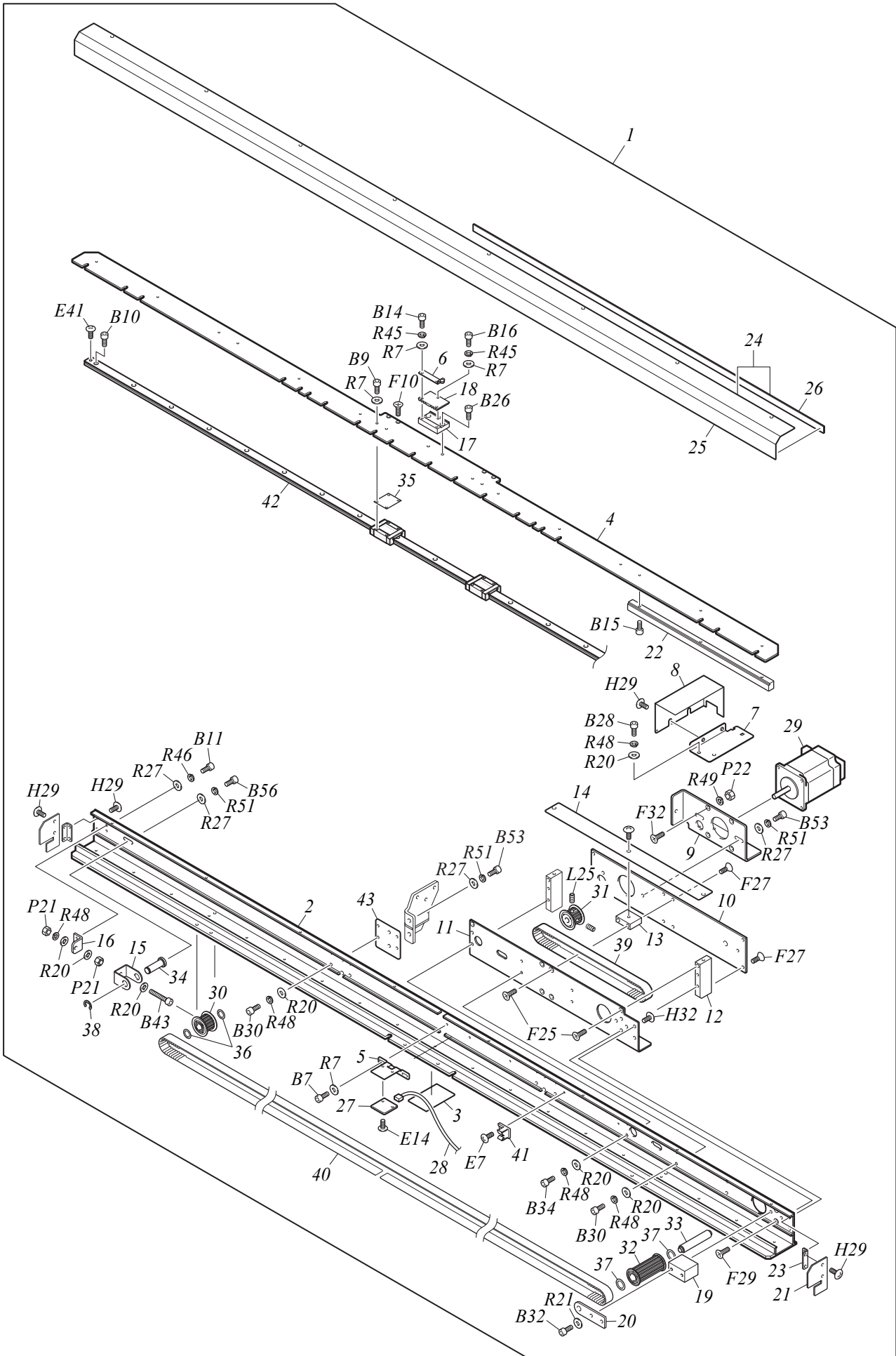

X-EXTENSION UNIT 1 (OPTION)

E1-16-1

No.	Part Name	Part No.	Remark
1	Z-SPEC. FRAME :0001/1200S[A]	0F4110530A00	
2	Z-SPEC. FRAME :0001/1200S[S]	0F4110520S10	
3	FELT :T1.9[S]	0G0140040S00	
4	FRAME HOLDER :1200S	0F4120240000	
5	BRACKET :MAGNETIC SENSOR	0F4140020000	
6	SENSOR PLATE :NO.1	0F4140030000	
7	STAY :HARNESS COVER	0F4150300000	
8	COVER :X MOTOR HARNESS	0F4150310000	
9	BASE :X MOTOR	0F4150360000	
10	PLATE :X MOTOR	0F4150370000	
11	BRACKET :X MOTOR	0F4150380000	
12	JOINT :PLATE :SIDE	0F4150390000	
13	JOINT :PLATE :CENTER	0F4150400000	
14	COVER :BELT	0F4150410000	
15	HOLDER :TIMING PULLEY	0F4160040000	
16	TENSIONER :X DRIVE BELT	0F4160050010	
17	BELT CATCHER :NO.1 :X	0F4160480000	
18	BELT CATCHER :NO.2 :X	0F4160490000	
19	BASE :SHAFT HOLDER PLATE	0F4160670000	
20	SHAFT HOLDER PLATE	0F4160680000	
21	COVER :Z-SPEC. FRAME SASH	0F4160690000	
22	LIFT-PREVENTIVE BLOCK :FRAME HOLDER	0F4160700000	
23	BRACKET :Z-SPEC. FRAME SASH COVER	0F5300350000	
24	COVER :Z-SPEC. FRAME :1200S[S]	0F5300440S00	
25	COVER :Z-SPEC. FRAME :1200S	0F5300440000	
26	FELT :12*2*45	0F4110020010	
27	CARD :MAGNETIC SENSOR A	0J4204400000	
28	HARNESS :X-AXIS FRAME ORIGIN SENSOR	H0E106100000	
29	PULSE MOTOR :60MM SQUARE :WITH SENSOR[A]	0J6105400A10	
30	TIMING PULLEY :W15-16[S]	501430060S10	
31	TIMING PULLEY :W15-16	501430140020	
32	TIMING PULLEY :W50-16[S]	501490030S10	
33	STEPPED PIN :NO.1	503201210000	
34	FLANGE PIN :NO.3	503503030000	
35	SPACER :NO.2 :T0.3	510200300000	
36	PLASTIC WASHER :10.2*15*T0.5	519212030000	
37	PLASTIC WASHER :12.2*18*T0.5	519214010000	
38	E-RING :7MM DIA.	611100100000	
39	TIMING BELT :SPTG :W15-S5M0520/G	623200510000	
40	TIMING BELT :MA5 :W15-550E/LY	623A00030000	
41	MINI CLAMP :MB-2	644100080000	
42	LINEAR WAY :LWL-15C3R1470	660300100000	
43	SPACER :Z-SPEC. FRAME SASH	0F4160710000	
44			
45			
46			
47			
48			
49			
50			

Note: As for parts with mark @, please follow our instructions on Table of Contents in your parts order.

(U004)

X-EXTENSION UNIT 2 (OPTION)

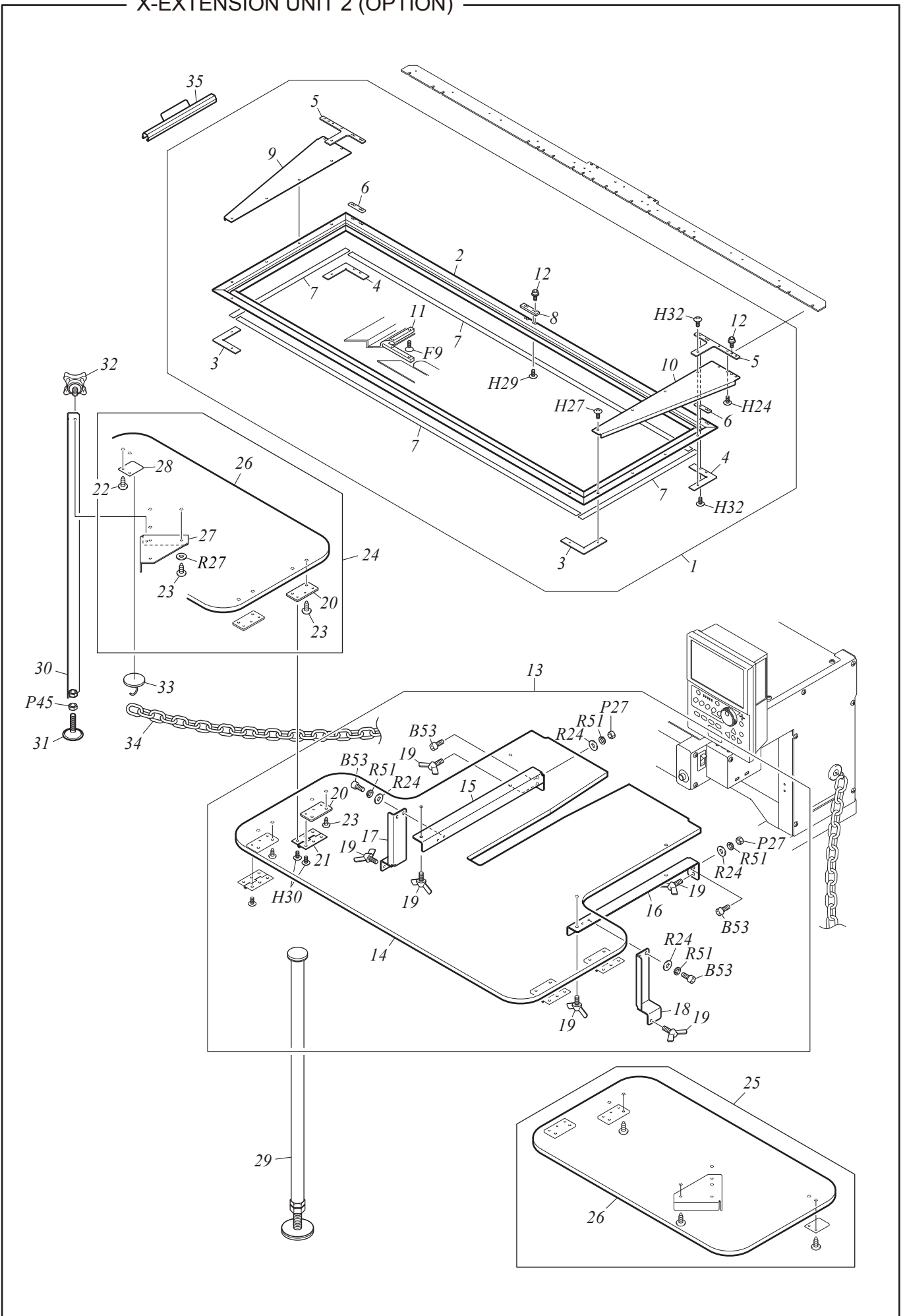

X-EXTENSION UNIT 2 (OPTION)

E1-16-2

No.	Part Name	Part No.	Remark
1	BORDER FRAME :0001/036*1200S[A]	303150040A00	
2	BORDER FRAME :0001/036*1200S	303150040000	
3	CORNER :BORDER FRAME :REAR	0G0220240020	
4	CORNER :BORDER FRAME :FRONT	0G0220530000	
5	CORNER :BORDER FRAME :UPPER	0G0220540000	
6	SPACER :CORNER	0G0220550000	
7	FELT :15*1.3*1000[S]	0G0240200S00	
8	SPACER :BORDER FRAME	0G0250150010	
9	SUPPORT :BORDER FRAME :L	0G028029L010	
10	SUPPORT :BORDER FRAME :R	0G028029R010	
11	CORNER :SQUARE FRAME :C	0G5400140000	
12	HEXAGON SOCKET HEAD FLANGE SCREW :M5*8	S123050801MZ	
13	TABLE :BORDER FRAME :X-EXTENSION UNIT[T]	0L3120091T30	
14	TABLE :BORDER FRAME	0L3120090020	
15	BASE :TABLE SUPPORT :L	0L312011L010	
16	BASE :TABLE SUPPORT :R	0L312011R010	
17	SUPPORT :TABLE :L	0L312012L010	
18	SUPPORT :TABLE :R	0L312012R010	
19	WING BOLT :TYPE 2 :M5*10	S180051001SD	
20	BRACKET :HINGE	0L3120150000	
21	HINGE :FLAT TYPE	615300020000	
22	TRUSS HEAD TAPPING SCREW :4P*10	S530041001SD	
23	TRUSS HEAD TAPPING SCREW :5P*16	S530051601SD	
24	TABLE :X-EXTENSION UNIT :L[A]	0L312019LA00	
25	TABLE :X-EXTENSION UNIT :R[A]	0L312019RA00	
26	TABLE :X-EXTENSION UNIT	0L3120190000	
27	BRACKET :TABLE SUPPORT	0L3120160000	
28	TABLE HOLDER	030610010010	
29	TABLE SUPPORT[A]	030540150A10	
30	TABLE SUPPORT :X-EXTENSION UNIT	0L312013C300	
31	ADJUSTER :55MM DIA.	614300220000	
32	KNOBBED SCREW :NO.2 :M5*6[S]	511F05110S00	
33	MAGNET HANGER :CR-MG101	615800120000	
34	PC CHAIN :YELLOW/BLACK :6MM DIA.	613300110000	
35	BORDER FRAME CLIP :BFF8 :L100-300[S]	0G052021@S00	
36			
37			
38			
39			
40			
41			
42			
43			
44			
45			
46			
47			
48			
49			
50			

Note: As for parts with mark @, please follow our instructions on Table of Contents in your parts order.

(U004)

A, B

No.	Part No.	Remark	No.	Part No.	Remark
A Flat Fillister Head Screw			B18	S120031501TN	M3*15
A1	SA41730351CN	1/8*44*3.5	B19	S120031601TN	M3*16
A2	SA41730501CN	1/8*44*5	B20	S120031801TN	M3*18
A3	SA41730551CN	1/8*44*5.5	B21	S120032003TD	M3*20
A4	SA41730601CN	1/8*44*6	B22	S120032001TN	M3*20
A5	SA41740301CN	9/64*40*3	B23	S120032501TN	M3*25
A6	SA41740402CN	9/64*40*4	B24	S120033001TN	M3*30 Half Threads
A7	SA41740401SA	9/64*40*4	B25	S120040501TD	M4*5
A8	SA41740403CL	9/64*40*4	B26	S120040502TN	M4*5
A9	SA41740404CN	9/64*40*4	B27	S120040602TD	M4*6
A10	SA41740501CN	9/64*40*5	B28	S120040601TN	M4*6
A11	SA41740601CN	9/64*40*6	B29	S120040801TD	M4*8
A12	SA41740602CN	9/64*40*6	B30	S120040802TN	M4*8
A13	SA41740701CN	9/64*40*7	B31	S120041001TD	M4*10
A14	SA41740801CN	9/64*40*8	B32	S120041002TN	M4*10
A15	SA41740802CN	9/64*40*8	B33	S120041201TD	M4*12
A16	SA41740803CN	9/64*40*8	B34	S120041202TN	M4*12
A17	SA41741001CN	9/64*40*10	B35	S120041401TN	M4*14
A18	SA41741202CN	9/64*40*12	B36	S120041502TD	M4*15
A19	SA41741501CN	9/64*40*15	B37	S120041501TN	M4*15
A20	SA41750431TN	11/64*40*4.3	B38	S120041601TN	M4*16
A21	SA41750701CN	11/64*40*7	B39	S120041801TN	M4*18
A22	SA41750751CN	11/64*40*7.5	B40	S120042002TD	M4*20
A23	SA41750901SH	11/64*40*9	B41	S120042001TN	M4*20
A24	SA41751151CN	11/64*40*11.5	B42	S120042502TD	M4*25
A25	SA41751201CN	11/64*40*12	B43	S120042501TN	M4*25
A26	S141030801SC	M3*8	B44	S120042504TN	M4*25 Half Threads
A27	S141030802SD	M3*8	B45	S120043001TN	M4*30
A28	S141031001CC	M3*10	B46	S120043502TD	M4*35
A29	S141041001SC	M4*10	B47	S120043501TN	M4*35
A30	SA41740653TB	9/64*40*6.5	B48	S120044001TN	M4*40
			B49	S120044501TN	M4*45
B Hexagon Socket Head Cap Screw			B50	S120050601TN	M5*6
B1	S120020801TD	M2*8	B51	S120050801TD	M5*8
B2	S120021001TD	M2*10	B52	S120050802TN	M5*8
B3	S120480501TN	M2.6*5	B53	S120051001TD	M5*10
B4	S120030301TN	M3*3	B54	S120051002TN	M5*10
B5	S120030401TN	M3*4	B55	S120051004TP	M5*10
B6	S120030502TD	M3*5	B56	S120051201TD	M5*12
B7	S120030501TN	M3*5	B57	S120051202TN	M5*12
B8	S120030601TD	M3*6	B58	S120051401TN	M5*14
B9	S120030602TN	M3*6	B59	S120051501MZ	M5*15
B10	S120030804MZ	M3*8	B60	S120051502TD	M5*15
B11	S120030801TD	M3*8	B61	S120051503TN	M5*15
B12	S120030802TN	M3*8	B62	S120051601TN	M5*16
B13	S120031001TD	M3*10	B63	S120051801TN	M5*18
B14	S120031002TN	M3*10	B64	S120052001TD	M5*20
B15	S120031203TD	M3*12	B65	S120052002TN	M5*20
B16	S120031201TN	M3*12	B66	S120052201TN	M5*22
B17	S120031502TD	M3*15	B67	S120052301TN	M5*23

B, C

No.	Part No.	Remark	No.	Part No.	Remark
B	Hexagon Socket Head Cap Screw		B117	S120102001TN	M10*20
B68	S120052501TN	M5*25	B118	S120102501TN	M10*25
B69	S120053001TN	M5*30	B119	S120103001TN	M10*30
B70	S120053503TD	M5*35	B120	S120103501TN	M10*35
B71	S120053501TN	M5*35	B121	S120104001TN	M10*40
B72	S120053502TN	M5*35 Half Threads	B122	S120123001TN	M12*30
B73	S120054001TN	M5*40	B123	S120123501TN	M12*35
B74	S120054501TN	M5*45	B124	S120081801TN	M8*18
B75	S120055001TN	M5*50	B125	S120470501TN	M2.5*5
B76	S120055002TN	M5*50 Half Threads	B126	S120052502TD	M5*25
B77	S120055501TN	M5*55	B127	S120030302TD	M3*3
B78	S120056001TN	M5*60	B128	S120051504TN	M5*15 Low Head
B79	S120056003TN	M5*60 Half Threads	B129	S120031801TD	M3*18
B80	S120060801TN	M6*8	B130	S120052801TN	M5*28
B81	S120060901TN	M6*9	B131	S120044502TN	M4*45 Half Threads
B82	S120061001TN	M6*10	B132	S120081501TD	M8*15
B83	S120061202TD	M6*12	B133	S120051802TD	M5*18
B84	S120061201TN	M6*12	B134	S120470401TN	M2.5*4
B85	S120061501TD	M6*15	B135	S120033003SD	M3*30
B86	S120061502TN	M6*15	B136	S120030402TD	M3*4
B87	S120061801TD	M6*18	B137	S120033002TN	M3*30
B88	S120061802TN	M6*18	B138	S120067502TN	M6*75
B89	S120062001TN	M6*20	B139	S120050501TN	M5*5
B90	S120062501TN	M6*25	B140	S120082001TD	M8*20
B91	S120063001TN	M6*30	B141	S120086002TD	M8*60
B92	S120063501TN	M6*35	B142	S120062002TD	M6*20
B93	S120064001TN	M6*40	B143	S120043503TD	M4*35 Half Threads
B94	S120064501TN	M6*45	B144	S120044003TN	M4*40 Half Threads
B95	S120064502TN	M6*45 Half Threads	B145	S120030605TD	M3*6 Low Head
B96	S120065001TN	M6*50 Half Threads	B146	S120042202TD	M4*22
B97	S120066501TN	M6*65	B147	S120062502TD	M6*25
B98	S120067501TN	M6*75 Half Threads	B148	S120045501TN	M4*55 Half Threads
B99	S120068001TN	M6*80 Half Threads	B149	S120123001TD	M12*30
B100	S12006A001TN	M6*100	B150	S120034001TN	M3*40
B101	S120081201TN	M8*12	B151	S120035001TN	M3*50
B102	S120081502TN	M8*15	B152	S120470502TD	M2.5*5
B103	S120081503TP	M8*15	B153	S120081202TD	M8*12
B104	S120081601TN	M8*16			
B105	S120082001TN	M8*20	C Hexagon Bolt		
B106	S120082502TN	M8*25	C1	S121030601SD	M3*6
B107	S120083001TN	M8*30	C2	S121040801SD	M4*8
B108	S120083501TN	M8*35	C3	S121042501SD	M4*25
B109	S120084001TN	M8*40	C4	S121051001SD	M5*10
B110	S120084002TN	M8*40 Half Threads	C5	S121051502SC	M5*15
B111	S120084501TN	M8*45	C6	S121051501SD	M5*15
B112	S120084502TN	M8*45 Half Threads	C7	S121052001SD	M5*20
B113	S120085001TN	M8*50	C8	S121061501SC	M6*15
B114	S120086001TN	M8*60	C9	S121062501TN	M6*25
B115	S120087001TN	M8*70	C10	S121064501SD	M6*45
B116	S120102002TD	M10*20	C11	S121065001SC	M6*50

C, D, E

No.	Part No.	Remark	No.	Part No.	Remark
C Hexagon Bolt			E7	S160470402MZ	M2.5*4
C12	S121065002SD	M6*50	E8	S160470501MZ	M2.5*5
C13	S121065501SD	M6*55	E9	S160470801MZ	M2.5*8
C14	S121066501SD	M6*65	E10	S160471301MZ	M2.5*13
C15	S121067501SC	M6*75	E11	S160471302SD	M2.5*13
C16	S121081501TN	M8*15	E12	S160480601SD	M2.6*6
C17	S121081801TN	M8*18	E13	S160030301MZ	M3*3
C18	S121103001TN	M10*30	E14	S160030302SD	M3*3
C19	S121103502SC	M10*35	E15	S160030403CD	M3*4
C20	S121103501TN	M10*35	E16	S160030401MZ	M3*4
C21	S121104001SC	M10*40	E17	S160030402SD	M3*4
C22	S121125001TN	M12*50	E18	S160030501MZ	M3*5
C23	S12112B001TN	M12*110	E19	S160030502SD	M3*5
C24	S121082501TN	M8*25	E20	S160030601MZ	M3*6
C25	S121102501TN	M10*25	E21	S160030603SA	M3*6
C26	S121082202TN	M8*22	E22	S160030602SD	M3*6
C27	S121041001SD	M4*10	E23	S160030801MZ	M3*8
C28	S121040601SD	M4*6	E24	S160030803SA	M3*8
C29	S121061503SD	M6*15	E25	S160030802SD	M3*8
			E26	S160031001MZ	M3*10
D Round Fillister Head Screw			E27	S160031003SC	M3*10 Half Threads
D1	SA43740401CL	9/64*40*4	E28	S160031002SD	M3*10
D2	SA43740501CL	9/64*40*5	E29	S160031101SC	M3*11 Half Threads
D3	SA43740502CN	9/64*40*5	E30	S160031201MZ	M3*12
D4	SA43740503CN	9/64*40*5	E31	S160031202SD	M3*12
D5	SA43740504CN	9/64*40*5	E32	S160031401SA	M3*14
D6	SA43740601CL	9/64*40*6	E33	S160031402SD	M3*14
D7	SA43740602CN	9/64*40*6	E34	S160031501SD	M3*15
D8	SA43740603CL	9/64*40*6	E35	S160031601SD	M3*16
D9	SA43740604CN	9/64*40*6	E36	S160031801SD	M3*18
D10	SA43740682CN	9/64*40*6.8	E37	S160032001SD	M3*20
D11	SA43740801CL	9/64*40*8	E38	S160033001SD	M3*30
D12	SA43740802CN	9/64*40*8	E39	S160034002SD	M3*40
D13	SA43741001CN	9/64*40*10	E40	S160035001SD	M3*50 Half Threads
D14	SA43741201CN	9/64*40*12	E41	S160040401SD	M4*4
D15	SA43750601CN	11/64*40*6	E42	S160040501SD	M4*5
D16	SA43750652CN	11/64*40*6.5	E43	S160040601MZ	M4*6
D17	SA43751051CN	11/64*40*10.5	E44	S160040602SD	M4*6
D18	SA43751201CN	11/64*40*12	E45	S160040801SD	M4*8
D19	SA43751501CN	11/64*40*15	E46	S160041001SD	M4*10
D20	SA43812451CN	9/32*28*24.5	E47	S160041201SD	M4*12
D21	S143030501SD	M3*5	E48	S160041501SD	M4*15
			E49	S160041801SD	M4*18
E Pan Head Screw			E50	S160043001SD	M4*30
E1	S160410141MZ	M1.4*1.4	E51	S160045001SD	M4*50
E2	S160020202MZ	M2*2	E52	S160046001SD	M4*60
E3	S160020301MZ	M2*3	E53	S160050601SD	M5*6
E4	S160020401MZ	M2*4	E54	S160050701SD	M5*7
E5	S160020801MZ	M2*8	E55	S160050801SD	M5*8
E6	S160470301MZ	M2.5*3	E56	S160051002MZ	M5*10

E, F, G, H

No.	Part No.	Remark	No.	Part No.	Remark
E Pan Head Screw			F27	S150040802SD	M4*8
E57	S160051001SD	M5*10	F28	S150041001MZ	M4*10
E58	S160051201SD	M5*12	F29	S150041002SD	M4*10
E59	S160053001SD	M5*12	F30	S150041201SD	M4*12
E60	S160051501SD	M5*15	F31	S150041401SD	M4*14
E61	S160054501SD	M5*45	F32	S150041501SD	M4*15
E62	S160055001SD	M5*50	F33	S150042001SD	M4*20
E63	S160056001SD	M5*60	F34	S150042201SD	M4*22
E64	S160047001SD	M4*70	F35	S150042501SD	M4*25
E65	S160480801SD	M2.6*8	F36	S150050601SD	M5*6
E66	S160030504SC	M3*5	F37	S150050801SD	M5*8
E67	S160480602MZ	M2.6*6	F38	S150051001MZ	M5*10
E68	S160031403MZ	M3*14	F39	S150051002SD	M5*10
E69	S160042001SD	M4*20	F40	S150051201SD	M5*12
E70	S160044501SD	M4*45	F41	S150051501SD	M5*15
E71	S160020203SD	M2*2	F42	S150053001SD	M5*30
E72	S160470502SD	M2.5*5	F43	S150053501SD	M5*35
E73	SA60740551TN	9/64*40*5.5	F44	S150054001SD	M5*40
E74	S160431001MZ	M1.7*10	F45	S150061502SC	M6*15
E75	S160043501SD	M4*35	F46	S150061503SD	M6*15
E76	S160020501SD	M2*5	F47	S150063501SD	M6*35
E77	S160052501SD	M5*25	F48	S150081201SD	M8*12
			F49	S150087001TN	M8*70
F Countersunk Head Screw			F50	S150061801SD	M6*18
F1	SA51741001CN	9/64*40*10	F51	S150052501SD	M5*25
F2	SA50750801CN	11/64*40*8			
F3	S150020601SD	M2*6	G Round Countersunk Head Screw		
F4	S150030401MZ	M3*4	G1	SA53730601CL	1/8*44*6
F5	S150030402SD	M3*4	G2	SA53740301CL	9/64*40*3
F6	S150030501MZ	M3*5	G3	SA53740351CL	9/64*40*3.5
F7	S150030502SD	M3*5	G4	SA53740401CL	9/64*40*4
F8	S151030601SD	M3*6	G5	SA53740601CL	9/64*40*6
F9	S150030601MZ	M3*6	G6	SA53740701CL	9/64*40*7
F10	S150030602SD	M3*6	G7	SA53740951CL	9/64*40*9.5
F11	S150030701SD	M3*7	G8	SA53741201CL	9/64*40*12
F12	S151030801SD	M3*8	G9	SA53740681CL	9/64*40*6.8
F13	S150030801MZ	M3*8			
F14	S150030804SC	M3*8	H Truss Head Screw		
F15	S150030802SD	M3*8	H1	SA30730701CL	1/8*44*7
F16	S150030803SN	M3*8	H2	SA30740301CL	9/64*40*3.5
F17	S150031002MZ	M3*10	H3	SA30740401CL	9/64*40*4
F18	S150031001SD	M3*10	H4	SA31740401CM	9/64*40*4
F19	S150031201MZ	M3*12	H5	SA30740601CL	9/64*40*6
F20	S150031202SD	M3*12	H6	SA30740801CL	9/64*40*8
F21	S150031501MZ	M3*15	H7	S130470301MZ	M2.5*3
F22	S150031601SD	M3*16	H8	S130470302SD	M2.5*3
F23	S150040501SD	M4*5	H9	S130470401MZ	M2.5*4
F24	S150040602MZ	M4*6	H10	S130470402SA	M2.5*4
F25	S150040601SD	M4*6	H11	S130470403SD	M2.5*4
F26	S150040801MZ	M4*8	H12	S130030301MZ	M3*3

H, J, K, L

No.	Part No.	Remark	No.	Part No.	Remark
H	Truss Head Screw		H62	S130031501SD	M3*15
H13	S130030302SD	M3*3	H63	S130043501SD	M4*35
H14	S130030402SD	M3*4	H64	S130020201SD	M2*2
H15	S130030501MZ	M3*5	H65	S130470501SD	M2.5*5
H16	S130030502SD	M3*5	H66	S130052002MZ	M5*20
H17	S130030601MZ	M3*6	H67	S130054501SE	M5*45
H18	S130030602SD	M3*6	H68	S130050502MZ	M5*5
H19	S130030603SA	M3*6	H69	S130054001SD	M5*40
H20	S130030802SD	M3*8	H70	S130055001SD	M5*50
H21	S130030803SA	M3*8	H71	S130030801MZ	M3*8
H22	S130031001MZ	M3*10	H72	S130052201SD	M5*22
H23	S130031002SD	M3*10	H73	S130041802MZ	M4*18
H24	S130032001SD	M3*20	H74	S130055501SD	M5*55
H25	S130040401MZ	M4*4			
H26	S130040401SD	M4*4	J Round Head Screw		
H27	S130040501MZ	M4*5	J1	S162020301MZ	M2*3
H28	S130040502SD	M4*5	J2	S162030801SD	M3*8
H29	S130040601MZ	M4*6	J3	S162030802SE	M3*8
H30	S130040602SD	M4*6	J4	S162031001MZ	M3*10
H31	S130040651SD	M4*6.5			
H32	S130040801MZ	M4*8	K Slotted Set Screw		
H33	S130040802SD	M4*8	K1	SA71730351CN	1/8*44*3.5
H34	S130040803MZ	M4*8 JIS	K2	SA71740601CN	9/64*40*6
H35	S130041002MZ	M4*10	K3	SA71750251CN	11/64*40*2.5
H36	S130041001SD	M4*10	K4	SA71750351CN	11/64*40*3.5
H37	S130041201SD	M4*12	K5	SA71750401CN	11/64*40*4
H38	S130041502SD	M4*15	K6	SA71750501CN	11/64*40*5
H39	S130042001SD	M4*20	K7	SA71790501CN	15/64*28*5
H40	S130050501SD	M5*5	K8	SA71791001CN	15/64*28*10
H41	S130050602MZ	M5*6	K9	SA71791501CN	15/64*28*15
H42	S130050601SD	M5*6	K10	SA71791701CN	15/64*28*17
H43	S130050651SD	M5*6.5	K11	SA71800401CN	1/4*40*4
H44	S130050701SD	M5*7	K12	SA71800451CN	1/4*40*4.5
H45	S130050801MZ	M5*8	K13	SA71800501CN	1/4*40*5
H46	S130050802SD	M5*8	K14	SA71800601CN	1/4*40*6
H47	S130051002MZ	M5*10	K15	SA71800801CN	1/4*40*8
H48	S130051001SD	M5*10	K16	SA71811201CN	9/32*28*12
H49	S130051201MZ	M5*12	K17	S171050601TN	M5*6
H50	S130051202SD	M5*12	K18	S171030601SD	M3*6
H51	S130051501SD	M5*15			
H52	S130052001SD	M5*20	L Hexagon Socket Head Set Screw		
H53	S130052502SD	M5*25	L1	SA70730251CN	1/8*44*2.5
H54	S130053001SD	M5*30	L2	SA70730301CN	1/8*44*3
H55	S130053501SD	M5*35	L3	SA70750901CN	11/64*28*9
H56	S130060801SD	M6*8	L4	SA70750401CN	11/64*40*4
H57	S130061001SD	M6*10	L5	SA70750601CN	11/64*40*6
H58	S130062201SD	M6*22	L6	SA70750801CN	11/64*40*8
H59	S130062501SD	M6*25	L7	SA70790401CN	15/64*28*4
H60	S130063501SD	M6*35	L8	SA70790901CN	15/64*28*9
H61	S130064001SD	M6*40	L9	S170470301TN	M2.5*3

L, M, N

No.	Part No.	Remark	No.	Part No.	Remark
L	Hexagon Socket Head Set Screw		M12	S124030801SC	M3*8
L10	S170030201TN	M3*2	M13	S124030502TC	M3*5
L11	S170030301TN	M3*3	M14	S124030402SD	M3*4
L12	S170030401TN	M3*4	M15	S124030601SD	M3*6
L13	S170030501TN	M3*5	M16	S124040401SD	M4*4
L14	S170030601TN	M3*6	M17	S124030602SC	M3*6
L15	S170030801TN	M3*8	M18	S124030503SD	M3*5
L16	S170040301TN	M4*3	M19	S124031001MZ	M3*10
L17	S170040401TN	M4*4	M20	S124041001SD	M4*10
L18	S170040501TN	M4*5	M21	S124051201SD	M5*12
L19	S170040601TN	M4*6			
L20	S170040602TN	M4*6 Half Threads	N	Screw with Washer	
L21	S170040801TN	M4*8	N1	S660480601SE	M2.6*6
L22	S170041001TN	M4*10	N2	S660030601SE	M3*6
L23	S170041201TN	M4*12	N3	S660030801SE	M3*8
L24	S170050401TN	M5*4	N4	S660031001SE	M3*10
L25	S170050501TN	M5*5	N5	S660031501SE	M3*15
L26	S170050601TN	M5*6	N6	S660031601SE	M3*16
L27	S170050801TN	M5*8	N7	S660031801SE	M3*18
L28	S170051001TN	M5*10	N8	S660040601SE	M4*6
L29	S170051201TN	M5*12	N9	S660040801SE	M4*8
L30	S170051501TN	M5*15	N10	S660041001SE	M4*10
L31	S170060501TN	M6*5	N11	S660041201SE	M4*12
L32	S170060601TN	M6*6	N12	S660045501SE	M4*55
L33	S170060801TN	M6*8	N13	S660051001SE	M5*10
L34	S170061001TN	M6*10	N14	S660051201SE	M5*12
L35	S170061801TN	M6*18	N15	S660051401SE	M5*14
L36	S170080801TN	M8*8	N16	S660051801SE	M5*18
L37	S170081001TN	M8*10	N17	S660030801MZ	M3*8
L38	S170081501TN	M8*15	N18	S660030502MZ	M3*5
L39	S170031001TN	M3*10	N19	S660031502MZ	M3*15
L40	S170031201TN	M3*12	N20	S660030603S1	M3*6 (P-4)
L41	S170053001TN	M5*30	N21	S660030802S1	M3*8 (P-3)
L42	S170061201TN	M6*12	N22	S660030604S1	M3*6 (P-3)
L43	S174060601TN	M6*6B	N23	S660031802S1	M3*18 (P-3)
L44	S170050802TN	M5*8 Narrow Treading	N24	S660040602S1	M4*6 (P-3)
L45	S170050602TN	M5*6 Narrow Treading	N25	S660040802S1	M4*8 (P-3)
			N26	S660041002S1	M4*10 (P-3)
			N27	S660043001S1	M4*30 (P-3)
M	Hexagon Socket Head Button Screw		N28	S660051002S1	M5*10 (P-3)
M1	S124030401SC	M3*4	N29	S660031803S1	M3*18 (P-4)
M2	S124040601SC	M4*6	N30	S660030505S1	M3*5 (P-4)
M3	S124040802SC	M4*8	N31	S660031504S1	M3*15 (P-4)
M4	S124040803SD	M4*8	N32	S660031002S1	M3*10 (P-4)
M5	S124051001SC	M5*10	N33	S660040803S1	M4*8 (P-4)
M6	S124051002SD	M5*10	N34	S660030504S1	M3*5 (P-3)
M7	S124051501SD	M5*15	N35	S660020401S1	M2*4 (P-4)
M8	S124081201SC	M8*12	N36	S660031505S1	M3*15 (P-3)
M9	S124081202SD	M8*12	N37	S660041202S1	M4*12 (P-3)
M10	S124081501SD	M8*15	N38	S660480401S1	M2.6*4 (P-4)
M11	S124030501SC	M3*5			

N, P, R

No.	Part No.	Remark	No.	Part No.	Remark
N39	S660031003S1	M3*10 (P-3)	P48	S212160001SD	M16 Type 3
			P49	S210200001SC	M20 Type 1
P Nut			P50	S212470001SC	M2.5 Type 3
P1	SB10730601CN	1/8*44*6*3	P51	SB12750701SC	11/64*7*2.2 Type 3
P2	SB10740601CL	9/64*40*6*2	P52	S211040001SD	M4 Type 2
P3	SB10740602CN	9/64*40*6*3	P53	SB12740601MZ	9/64*6*2 Type 3
P4	SB10750602CN	11/64*40*6*2	P54	SB10750601CN	11/64*6*2.2
P5	SB10750603CN	11/64*40*6*3	P55	S212030003SD	M3 Type 3
P6	SB10750701CN	11/64*40*7*3	P56	S217060001SD	M6 Cap
P7	SB11750701CN	11/64*40*7*3	P57	S217030001SD	M3 Cap
P8	S210420001XA	M1.6 Type 1	P58	S212200001SC	M20 Type 3
P9	S210020001SD	M2 Type 1	P59	S212160002SC	M16 Type 3
P10	S212020002SD	M2 Type 3	P60	SB10750702CN	11/64*7*2.2
P11	S210460002SD	M2.3 Type 1	P61	SB10740605CN	9/64*40*6*1.5
P12	S210470001MZ	M2.5 Type 1			
P13	S212480001SD	M2.6 Type 3	R Washer		
P14	S210030001MZ	M3 Type 1	R1	S301410301MZ	Plain M1.4*3*t0.3
P15	S210030002SC	M3 Type 1	R2	S301020351XZ	Plain M2*3.5*t0.5
P16	S210030003SD	M3 Type 1	R3	S301020431SD	Plain M2*4.3*t0.3
P17	S215030001SD	M3 Thumbscrew Type 2	R4	S301480501XB	Plain M2.6*5*t0.5
P18	S212030001SC	M3 Type 3	R5	S301480751XB	Plain M2.6*7.5*t0.5
P19	S212030002SD	M3 Type 3	R6	S301030602XZ	Plain M3*6*t0.3
P20	S212530001SC	M3.5 Type 3	R7	S301030603SC	Plain M3*6*t0.5
P21	S210040001SC	M4 Type 1	R8	S301030601SD	Plain M3*6*t0.5
P22	S210040002SD	M4 Type 1	R9	S301030701SD	Plain M3*7*t0.5
P23	S212040001SC	M4 Type 3	R10	S301030804SD	Plain M3*8*t0.3
P24	S212040002SD	M4 Type 3	R11	S301030805MZ	Plain M3*8*t0.5
P25	S217040001SD	M4 Cap	R12	S301030801SC	Plain M3*8*t0.5
P26	S210050001SC	M5 Type 1	R13	S301030802SD	Plain M3*8*t0.5
P27	S210050002SD	M5 Type 1	R14	S301030803SD	Plain M3*8*t1
P28	S212050001SC	M5 Type 3	R15	S301040805SC	Plain M4*8*t0.5
P29	S212050002SD	M5 Type 3	R16	S301040802SD	Plain M4*8*t0.5
P30	S217050001SD	M5 Cap	R17	S301040804SC	Plain M4*8*t0.8
P31	S210060001SC	M6 Type 1	R18	S301040803SD	Plain M4*8*t0.8
P32	S210060002SC	M6 Type 1 (Left)	R19	S301041004MZ	Plain M4*10*t0.8
P33	S210060003SD	M6 Type 1	R20	S301041002SC	Plain M4*10*t0.8
P34	S210060004SD	M6 Type 1 (Left)	R21	S301041003SD	Plain M4*10*t0.8
P35	S212060001SC	M6 Type 3	R22	S301041201SC	Plain M4*12*t1
P36	S210080001SC	M8 Type 1	R23	S301051002SC	Plain M5*10*t0.8
P37	S210080002SD	M8 Type 1	R24	S301051003SD	Plain M5*10*t0.8
P38	S212080001SC	M8 Type 3	R25	S301051204MZ	Plain M5*12*t0.8
P39	S212080002SD	M8 Type 3	R26	S301051202SC	Plain M5*12*t0.8
P40	S210100001SC	M10 Type 1	R27	S301051203SD	Plain M5*12*t0.8
P41	S213100002SD	M10 With Flange	R28	S301061102SC	Plain M6*11*t1.6
P42	S213100003SD	M10 With Disk Spring	R29	S301061151SC	Plain M6*11.5*t0.8
P43	S210120001SC	M12 Type 1	R30	S301061301SC	Plain M6*13*t1.0
P44	S212120001SC	M12 Type 3	R31	S301061302SD	Plain M6*13*t1.0
P45	S212120002SD	M12 Type 3	R32	S301061601SC	Plain M6*16*t1.0
P46	S210160001SD	M16 Type 1	R33	S301081601SD	Plain M8*16*t1.2
P47	S212160002SC	M16 Type 1	R34	S301081801SC	Plain M8*18*t1.6

R

No.	Part No.	Remark	No.	Part No.	Remark
R	Washer		<i>R84</i>	S402120002KD	Spring M12
R35	S301081802SD	Plain M8*18*t1.6			
R36	S301081803SC	Plain M8*18*t3.2			
R37	S301082201SC	Plain M8*22*t3.2			
R38	S301102201SC	Plain M10*22*t1.6			
R39	S301102601SC	Plain M10*26*t3.2			
R40	S301102602SD	Plain M10*26*t3.2			
R41	S301122051SC	Plain M12*20.5*t2			
R42	S301163201SD	Plain M16*32*t2.5			
R43	S402020001KD	Spring M2			
R44	S402480001KC	Spring M2.6			
R45	S402030001KC	Spring M3			
R46	S402030002KD	Spring M3			
R47	S402530001KC	Spring M3.5			
R48	S402040001KC	Spring M4			
R49	S402040002KD	Spring M4			
R50	S402050001KC	Spring M5			
R51	S402050002KD	Spring M5			
R52	S402050003MZ	Spring M5			
R53	S402060001KC	Spring M6			
R54	S402060002KD	Spring M6			
R55	S402080001KC	Spring M8			
R56	S402080002KD	Spring M8			
R57	S402100001KC	Spring M10			
R58	S402100002KD	Spring M10			
R59	S402120001KC	Spring M12			
R60	S305041101TP	Wave M4			
R61	S305051001TN	Wave M5			
R62	S305061051TN	Wave M6			
R63	S304040851TP	With teeth M4			
R64	S304051001TP	With teeth M5			
R65	S306080001SC	Slant M8			
R66	S303040801SC	Disk Spring M4			
R67	S301041005EZ	Plain M4*10*t0.8			
R68	S301470252MZ	Plain M2.5*5*t0.5			
R69	S301030605SD	Plain M3*6*t1.0			
R70	S301030604MZ	Plain M3*6*t0.5			
R71	S305051101TN	Wave M5			
R72	S301470253SD	Plain M2.5*5*t0.5			
R73	S301470251SC	Plain M2.5*5*t0.5			
R74	S305101451TN	Wave M10			
R75	S304080001TP	With teeth M8			
R76	S301061152SD	Plain M6*11.5*t0.8			
R77	S301122601SC	Plain M12*26*t2.3			
R78	S304060002SD	With teeth M6			
R79	S304040852TP	With teeth M4 Outward			
R80	S301041202SD	Plain M4*12*t1.0			
R81	S301040901EZ	Plain M4*9*t0.3			
R82	S301051207EZ	Plain M5*12*t1.0			
R83	S301122601SD	Plain M12*26*t2.3			

1st Edition December, 2015

3rd Edition April, 2017

■ **Manufactured by:**

Tokai Industrial Sewing Machine Co., Ltd.

NO.1800, Ushiyama-cho, Kasugai, Aichi-pref., 486-0901, Japan
Telephone:568-33-1161 Fax:568-33-1191

■ **Distributed by:**

Tajima Industries Ltd.

19-22, Shirakabe, 3-chome, Higashi-ku, Nagoya, 461-0011, Japan
Telephone:52-932-3444 Fax:52-932-2457

●Copy, reprint, or reform of a part or whole of this manual without permission is prohibited.

THE TAJIMA GROUP

<http://www.tajima.com>

Tajima Industries Ltd.

19-22, Shirakabe, 3-chome, Higashi-ku, Nagoya, 461-0011, JAPAN
TEL.81-52-932-3811 FAX.81-52-932-3815

Tokai Industrial Sewing Machine Co.,Ltd.

NO.1800, Ushiyama-cho, Kasugai, Aichi-pref., 486-0901, JAPAN
TEL.81-568-33-1161 FAX.81-568-33-1191