

F 系列零件图册（V1 版）

F Series Parts Catalogue (Version V1)

适用于 F 系列：FBA、FHB、FHT、FHS、FHP 标配机型
Applicable to F Series: FBA, FHB, FHT, FHS, FHP, Standard

目录

Contents

目录	1-4
Contents	
前言	5
Foreword	
40010V1.机架部分图.....	6
40010V1. Rack diagram	
40010V1.机架部分表.....	7
40010V1. Rack table	
40020V1.台板部分图.....	8
40020V1. Platen diagram	
40020V1.台板部分表.....	9
40020V1. Platen table	
40030V1.主轴传动系统图.....	10
40030V1. Main shaft transmission diagram	
40030V1.主轴传动系统表.....	11

40030V1. Main shaft transmission table	
40040V1.旋梭箱部分图.....	12
40040V1. Hook arm diagram	
40040V1.旋梭箱部分表.....	13
40040V1. Hook arm table	
40050V1.机头系统-单凸单驱电磁铁跳跃部分图.....	14
40050V1. Arm - Single convex and single drive jumping electromagnet diagram	
40050V1.机头系统总表一.....	15
40050V1. Arm system table 1	
40050V1.机头系统总表二.....	16
40050V1. Arm system table 2	
40051V1.机头系统-双凸双驱电机跳跃部分图一.....	17
40051V1. Arm - Double convex and double drive jumping motor diagram 1	

40051V1.机头系统-双凸双驱电机跳跃部分图二.....	18
40051V1. Arm - Double convex and double drive jumping motor diagram 2	
40051V1.机头系统总表一.....	19
40051V1. Arm system table 1	
40051V1.机头系统总表二.....	20
40051V1. Arm system table 2	
40060V1.针杆架系统-整体式压脚部分图.....	21
40060V1. Needle bar case system – integral presser diagram	
40060V1.针杆架系统总表.....	22
40060V1. Needle bar case system general table	
40061V1.针杆架系统-分体式压脚部分图.....	23
40061V1. Needle bar case system – split presser diagram	
40061V1.针杆架系统总表.....	24
40061V1. Needle bar case system general table	
40070V1.换色系统-交流换色部分图.....	25

40070V1. Color change system – alternating color change diagram	
40070V1.换色系统-交流换色部分表.....	26
40070V1. Color change system – alternating color change table	
40071V1.换色系统-步进丝杠换色部分图.....	27
40071V1. Color change system – step and screw color change diagram	
40071V1.换色系统-步进丝杠换色部分表.....	28
40071V1. Color change system – step and screw color change table	
40080V1.剪线系统-电磁铁剪线部分图.....	29
40080V1. Trimming system – electromagnet trimming diagram	
40080V1.剪线系统-电磁铁剪线部分表.....	30
40080V1. Trimming system – electromagnet trimming table	

40081V1.剪线系统-步进电机剪线部分图.....	31
40081V1. Trimming system –step motor trimming diagram	
40081V1.剪线系统-步进电机剪线部分表.....	32
40081V1. Trimming system –step motor trimming table	
40090V1.勾线系统-交流集中勾线部分图.....	33
40090V1. Hooking system –alternating centralized hooking diagram	
40090V1.勾线系统-交流集中勾线部分表.....	34
40090V1. Hooking system –alternating centralized hooking table	
40100V1.X 驱动系统-步进电机驱动部分图.....	35
40100V1. X drive system – step motor drive diagram	
40100V1.X 驱动系统-步进电机驱动部表.....	36
40100V1. X drive system – step motor drive table	
40101V1. X 驱动系统-伺服电机驱动部分图.....	37
40101V1. X drive system –servo motor drive diagram	
40101V1.驱动系统-伺服电机驱动部分表.....	38
40101V1. X drive system –servo motor drive table	

40102V1.驱动系统-伺服电机驱动箱部分图.....	39
40102V1. Drive system –servo motor drive box diagram	
40102V1.驱动系统-伺服电机驱动箱部分表.....	40
40102V1. Drive system –servo motor drive box table	
40110V1.Y 驱动系统-步进电机驱动部图.....	41
40110V1. Y drive system –step motor drive diagram	
40110V1. Y 驱动系统-步进电机驱动部表.....	42
40110V1. Y drive system –step motor drive table	
40111V1.Y 驱动系统-伺服电机驱动部分图.....	43
40110V1. Y drive system –servo motor drive diagram	
40111V1.Y 驱动系统-伺服电机驱动部表.....	44
40110V1. Y drive system –servo motor drive table	
40120V1.绣框部分图.....	45
40120V1. Frame diagram	
40120V1.绣框部分表.....	46
40120V1. Frame table	

40121V1.绣框选配部分图.....	47
40121V1. Frame optional parts diagram	
40121V1.绣框选配部分表.....	48
40121V1. Frame optional parts table	
40130V1.线盘线架部分图.....	49
40130V1. Thread coil and stand diagram	
40130V1.线盘线架部分表.....	50
40130V1. Thread coil and stand table	
40140V1.电控系统-轮+簧夹线器部分图.....	51
40140V1. Electronic control system –wheel + spring thread tension base diagram	
40140V1.电控系统总表一.....	52
40140V1. Electronic control system general table 1	
40140V1.电控系统总表二.....	53
40140V1. Electronic control system general table 2	
40141V1.电控系统-纯轮夹线器部分图.....	54
40141V1. Electronic control system – wheel thread tension base diagram	
40141V1.电控系统总表一.....	55

40141V1. Electronic control system general table 1	
40141V1.电控系统总表二.....	56
40141V1. Electronic control system general table 2	
40150V1.面线夹持装置图.....	57
40150V1. Face thread holding device diagram	
40150V1.面线夹持装置表.....	58
40150V1. Face thread holding device table	

前言

Foreword

尊敬的客户，本零件图册是为方便维修购买零件时的参考资料，由于不断的研究开发新产品，不断提升新技术，产品的质量也不断改良，零件也在不断的更新中，故本零件图册不能作为任何法律依据，在选用零件前请客户先确认本零件图册是否跟自己所使用的机器零件相符。任何用户所购买的零部件在使用时应由专业技术人员正确安装及仔细阅读相关机器的操作、维修、保养说明书，对于没有正确安装或定时保养而导致的质量问题，本公司将不承担任何责任。

Dear customer, this parts list is only used as reference for purchase of parts in case of maintenance. The parts are in constant update due to the continuous development of new products, improving new technologies and product performance, therefore this parts list cannot serve as any legal basis. Please confirm whether this parts list is consistent with your parts before choosing the parts. Any parts purchased should be installed by professionals following the operation, repair and maintenance instructions of relevant machine. We bear no any responsibility for the quality problems caused by improper installation or failure to regularly maintain the equipment.

因为本零件图册上的零件对应的是本公司“F”型系列的全部机型，而“F”型系列包含多种机型，所以选购零件时如果零件编码中有“*”时，除了提供该零件编号外还须提供该机器的出厂序列号（在机器铭牌上），方便售后服务人员核对该机器的具体配置情况后准确发出所需要的零件。

This parts list contains parts of all models of “F” series of the company, and the “c” series has many models, so when purchasing the parts, it's essential to have the factory serial number (on nameplate) in addition to part number if the part number has “*”, which is convenient for the after-sales service employees to check the specific configuration of the machine and send the required parts exactly.

本公司享有该零件图册的解释权。

We reserve all the right for the interpretation of this parts list.

40010V1 机架部分图

40010V1. Rack Diagram

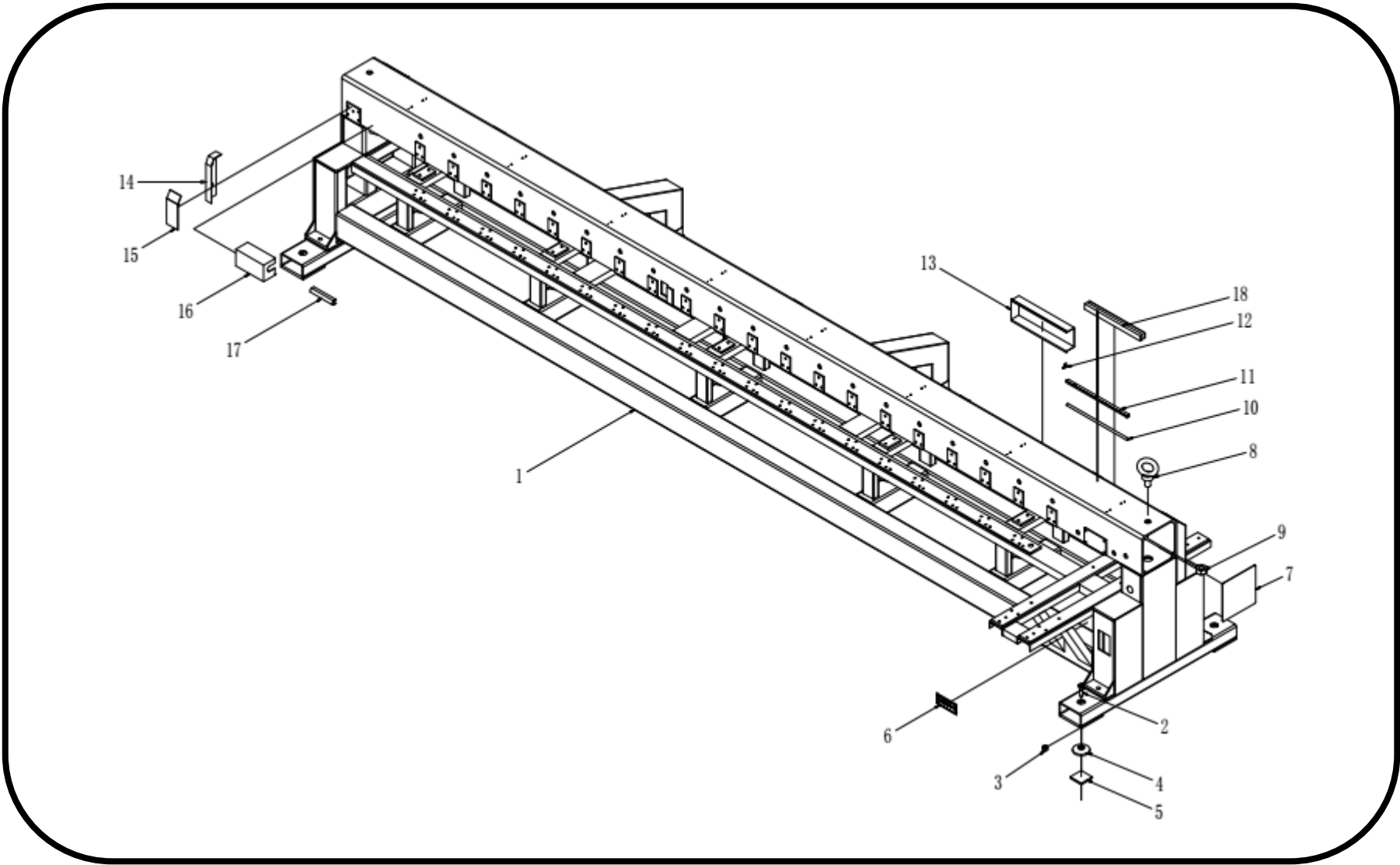

40010V1 机架部分表
40010V1. Rack Table

指引号 Ref. No.	物料编码 Part No.	名称 Part Name		备注 Remark	指引号 Ref. No.	物料编码 Part No.	名称 Part Name	备注 Remark
1	4060*****	机架	Machine rack					
2	80822010	外六角螺栓-M20X100	Outer hexagon bolt - M20X100					
3	80902021	螺母 M20-不锈钢	Nut M20 - stainless steel					
4	80272101	圆脚垫	Round foot pad					
5	71020311	橡胶垫	Rubber pad					
6	80050211	铭牌-中性	Nameplate - neutral					
7	400107**	大梁罩盖	Cross beam cover					
8	400108**	吊环	Ring					
9	400109**	吊环螺母	Eyenuit					
10—11	400110**	日光灯套件	LED lamp kit					
12	80240110	日光灯卡-T5	LED lamp clip - T5					
13	400113	机头板罩盖	Arm plate cover					
14	4001140000	上下传动箱侧罩盖	Up and down					

40020V1 台板部分图

40020V1. Platen Diagram

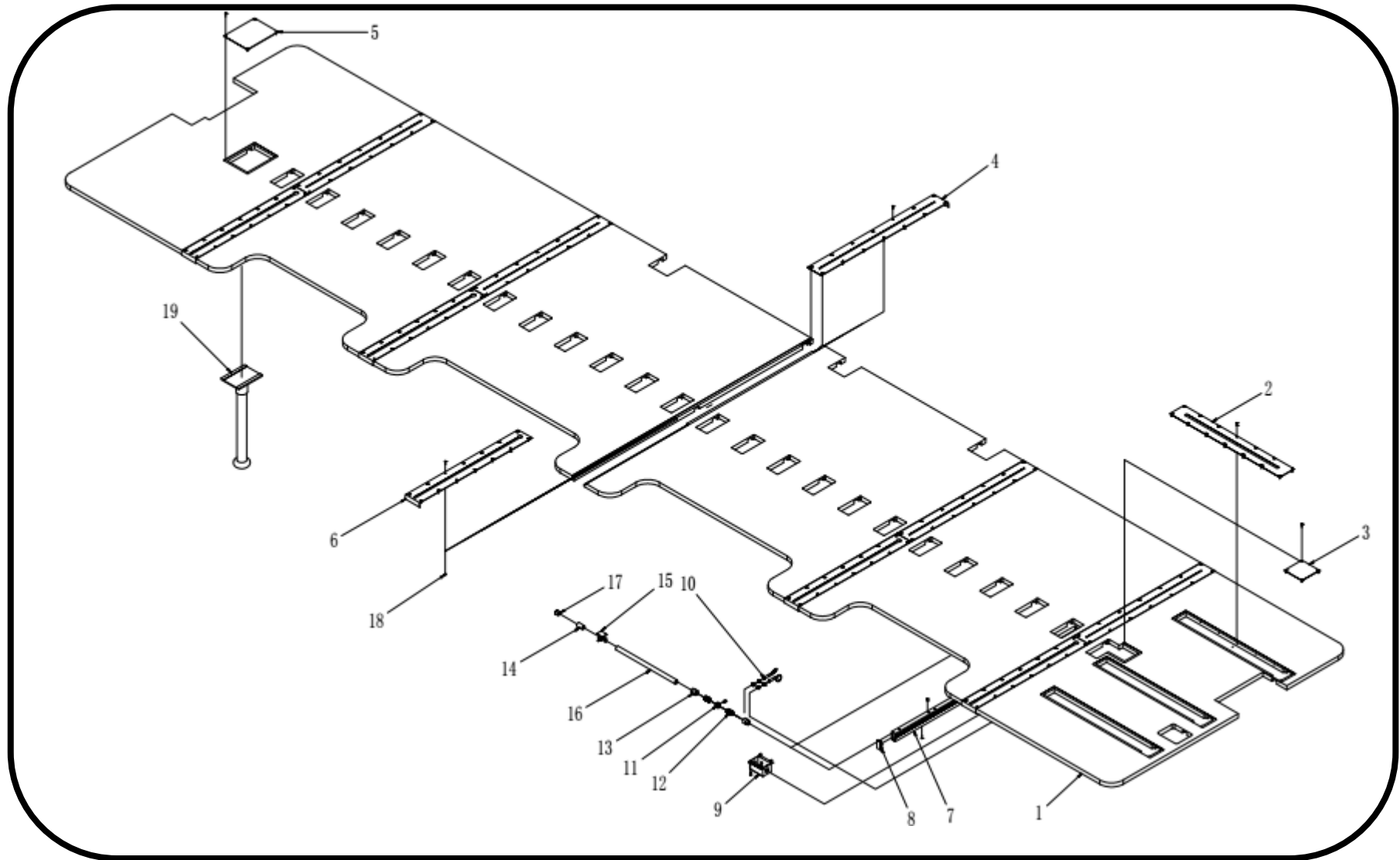

40020V1 台板部分表

40020V1 Platen Table

指引号 Ref. No.	物料编码 Part No.	名称 Part Name		备注 Remark	指引号 Ref. No.	物料编码 Part No.	名称 Part Name	备注 Remark
1	4061*****	台板	Platen					
2	400202*****	驱动不锈钢盖板-X***	Drive stainless steel cover plate - X***					
3	4002030000	编码器不锈钢盖板	Stainless steel cover plate of encoder					
4	400204*****	驱动不锈钢后盖板-Y***	Drive stainless steel rear cover plate - Y***					
5	400205*****	剪线箱不锈钢盖板	Stainless steel cover plate of trimming box					
6	400206*****	驱动不锈钢前盖板-Y***	Drive stainless steel front cover plate - Y***					
7	400207*****	铝合金台板支撑	Aluminum alloy support of platen					
8	01540231	台板支撑塞头	Chock plug of platen support					
9	4002090000	拉杆开关箱	Pull-rod switch box					
10	80333602	圆柱接近开关 NPN	Column proximity switch NPN					
11	4002110000	感应铁圈	Induction iron ring					

40030V1 主轴传动系统图
40030V1. Main Shaft Transmission Diagram

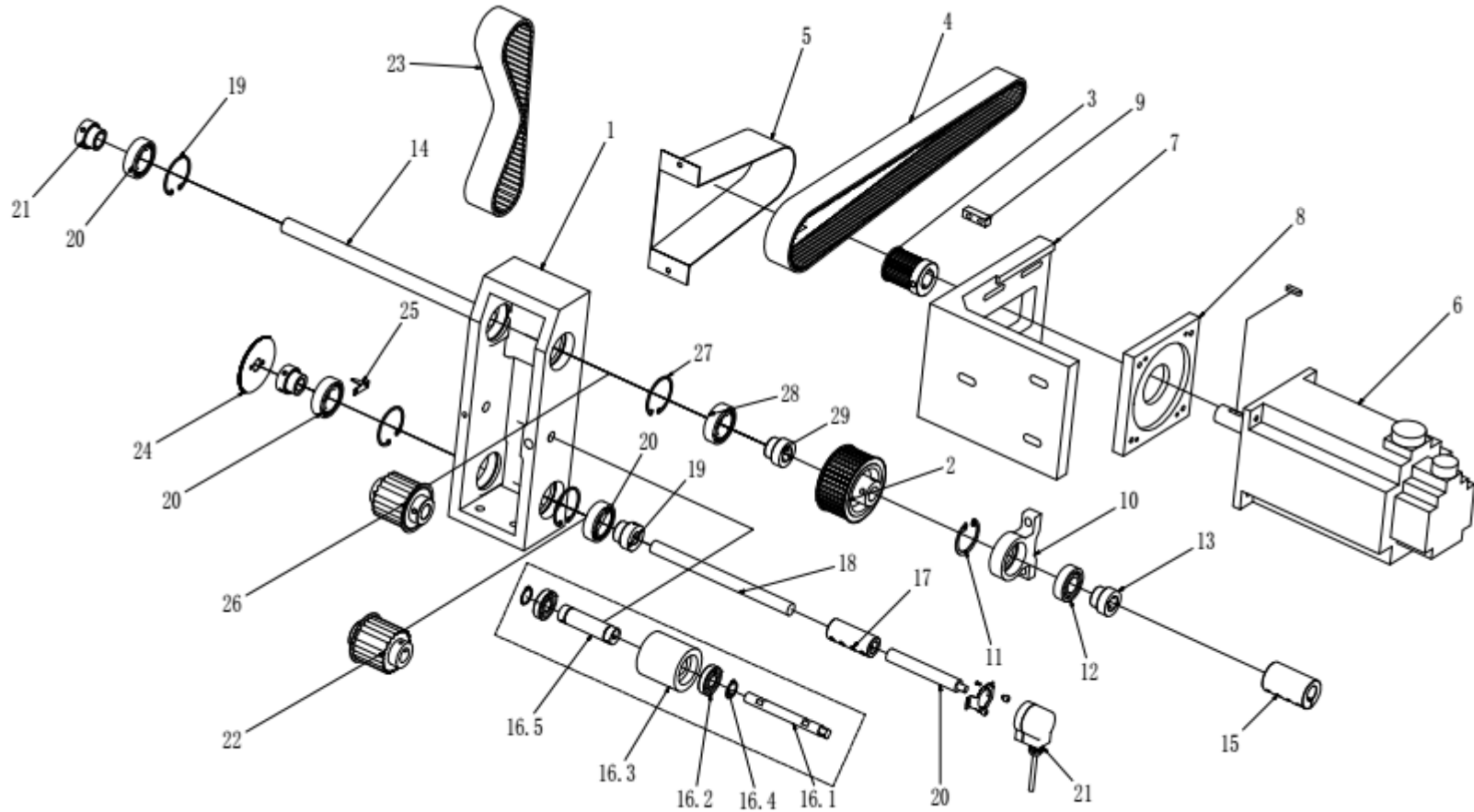

40030V1 主轴传动系统表
40030V1. Main Shaft Transmission Table

指引号 Ref. No.	物料编码 Part No.	名称 Part Name		备注 Remark	指引号 Ref. No.	物料编码 Part No.	名称 Part Name		备注 Remark
1	4003010000	上下传动箱箱体	Up and down transmission box body		20	02312108	编码器轴-875	Encoder shaft - 875	
2	4003020000	主轴同步带轮	Main shaft synchronous pulley		21	80330101	主轴编码器	Main shaft encoder	
3	4003030000	主轴电机同步带轮	Spindle motor synchronous pulley		22	80028211	带轮 22-S8M-40BF-孔 15	Pulley 22-S8M-40BF – Bore 15	
4	400304****	橡胶同步带 S5M-*****	Rubber synchronous belt S5M-*****		23	80028111	橡胶同步带 S8M-600-40	Rubber synchronous belt S8M-600-40	
5	4003050000	主轴皮带罩盖	Main shaft belt cover		24	80050101	主轴刻度盘	Main shaft dial	
6	4003060000	主轴电机-按电控配置	Main shaft motor – configure as per electronic control		25	02311141	刻度盘指针	Dial needle	
7	4003070000	主轴伺服电机座	Main shaft servo motor base		26	80050101	圆形刻度盘	Round dial	
8	4003080000	主轴伺服电机安装板	Main shaft servo mounting plate		27	80034781	内卡簧-47	Circlip – 47	
9	4003090000	主轴电机张力调节块	Main shaft tension adjusting block		28	80032501	轴承-6005	Bearing - 6005	
10	02311111	轴承座-42-高45	Bearing base – 42 –height 45		29	80031803	轴承套 Φ18-25	Bearing housing Φ18-25	
11	80034281	内卡簧-42	Circlip - 42						

40030V1 主轴传动系统表
40030V1. Main Shaft Transmission Table

12	80032022	深沟滚珠轴承-6004	Deep groove ball bearing - 6004						
13	80031801	轴承套-外 20 内 18	Bearing housing - external 20 internal 18						
14	400314****	上轴传动箱轴 Φ18-**	Upper shaft transmission shaft Φ18-**						
16	01053161	上下传动涨紧 轮组件	Up and down transmission tensioning wheel assembly						
16.1	4003160100	张紧轮轴	Tensioning wheel shaft						
16.2	4003160200	轴承	Bearing						
16.3	4003160300	张紧轮	Tensioning wheel						
16.4	4003160400	卡簧	Circlip						
16.5	4003160500	偏心套	Eccentric bushing						
17	80031511	轴接套 Φ15-60	Coupling sleeve Φ15-60						
18	02311013	轴 15-2600	Shaft 15-2600						
19	80031503	轴承套 Φ15-25	Bearing housing						

40040V1 旋梭箱部分图
40040V1. Rotary hook Hook Arm Diagram

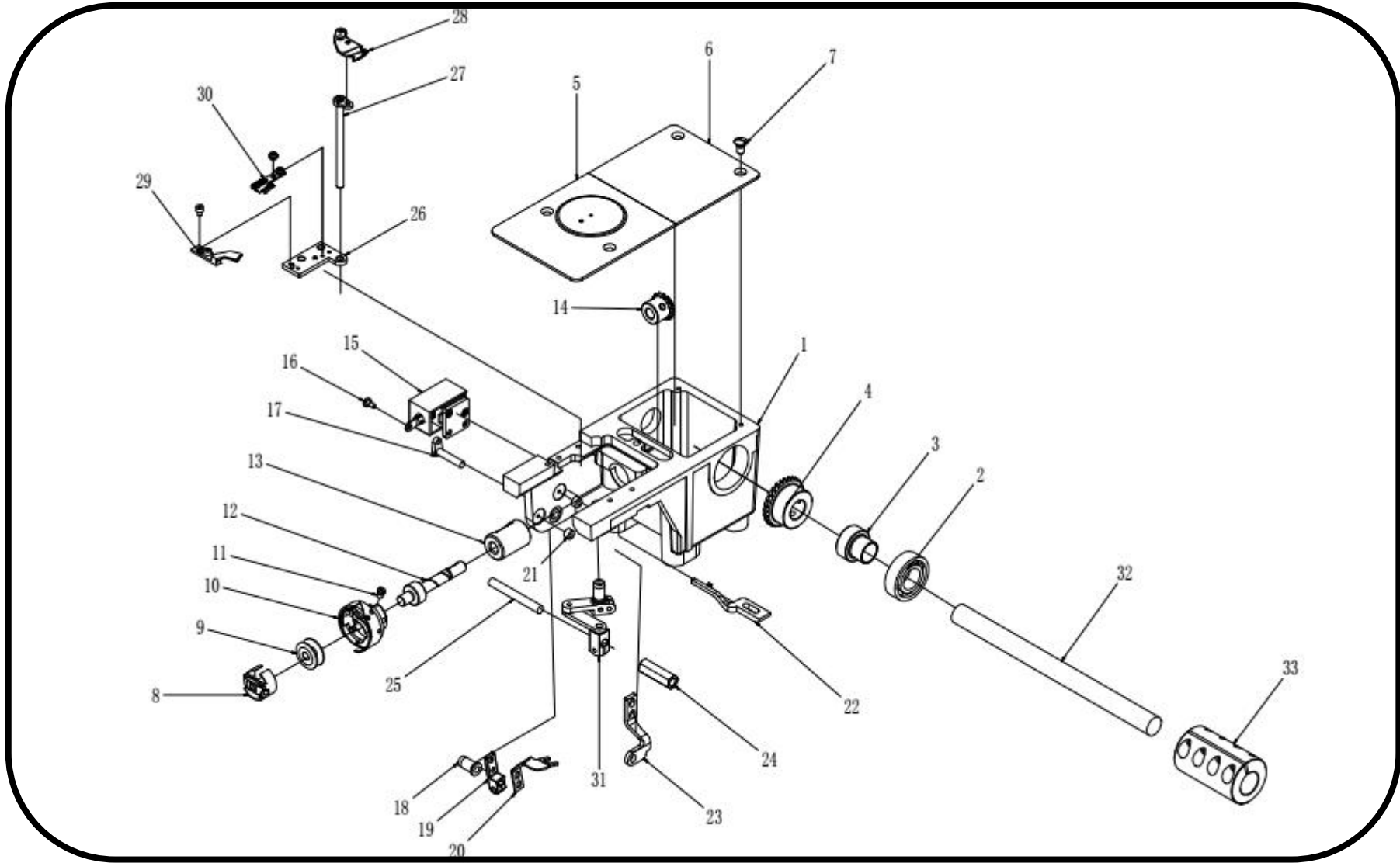

40040V1 旋梭箱部分表
40040V1. Rotary hook Hook Arm Table

指引号 Ref. No.	物料编码 Part No.	名称 Part Name		备注 Remark	指引号 Ref. No.	物料编码 Part No.	名称 Part Name		备注 Remark
1	01030113	剪线梭箱	Trimming shuttle box		25	80030601	拉杆-Φ6	Pull rod -Φ6	
2	80031722	深沟球轴承-6003	Deep groove ball bearing - 6003		26	01400301	剪线刀座	Thread trimmer base	
3	80031501	轴承套 Φ15-17	Bearing housingΦ15-17		27	01400302	活动刀杆	Movable knife rod	
4	01030131	大伞齿	Big bevel gear		28	01400303	活动刀	Movable knife	
6	01030141	前针板-平绣标准	Front needle plate – plain embroidery standard		29	01400304	固定刀	Fixed knife	
6	01030142	后针板-平绣标准	Rear needle plate – plain embroidery standard		30	01400371	线夹弹片	Clamp spring	
7	80924131	针板螺丝 11/64x6	Needle plate screw 11/64x6		31	01400362	活动刀驱动连杆	Movable knife drive rod	
8	80620301	梭壳	Bobbin case		32	02311013	轴—Φ15	Bearing - Φ15	
9	80620302	梭心	Bobbin		33	80031511	连轴套 Φ15	Coupling shaft bushingΦ15	
10	400410****	旋梭	Rotary hook						
11	400411****	旋梭固定螺丝	Rotary hook fixing screw						

40040V1 旋梭箱部分表
40040V1. Rotary hook Hook Arm Table

12	01030121	旋梭轴	Rotary hook shaft						
13	02101131	旋梭轴套	Rotary hook shaft bushing						
14	01030132	小伞齿	Small bevel gear						
15	80320203	扣线电磁铁-DC45V	Thread fork electromagnet - DC45V						
16	01420205	扣线连杆销	Thread fork rod pin						
17	01420204	扣线连杆轴	Thread fork rod shaft						
18	01400315	轴套-5	Bearing housing - 5						
19	01420202	扣线叉支架	Thread fork support						
20	01420201	扣线叉	Thread fork						
21	01030124	偏心胶	Eccentric glue						
22	01030120	旋梭定位勾	Rotary hook positioning hook						
23	01400312	拉杆支架	Pull-rod support						
24	80030603	拉杆接头-Φ6	Pull-rod joint -Φ6						

40050V1 机头系统-单凸单驱电磁铁跳跃部分图

40050V1. Machine Head - Single Convex and Single Drive Jumping Electromagnet Diagram

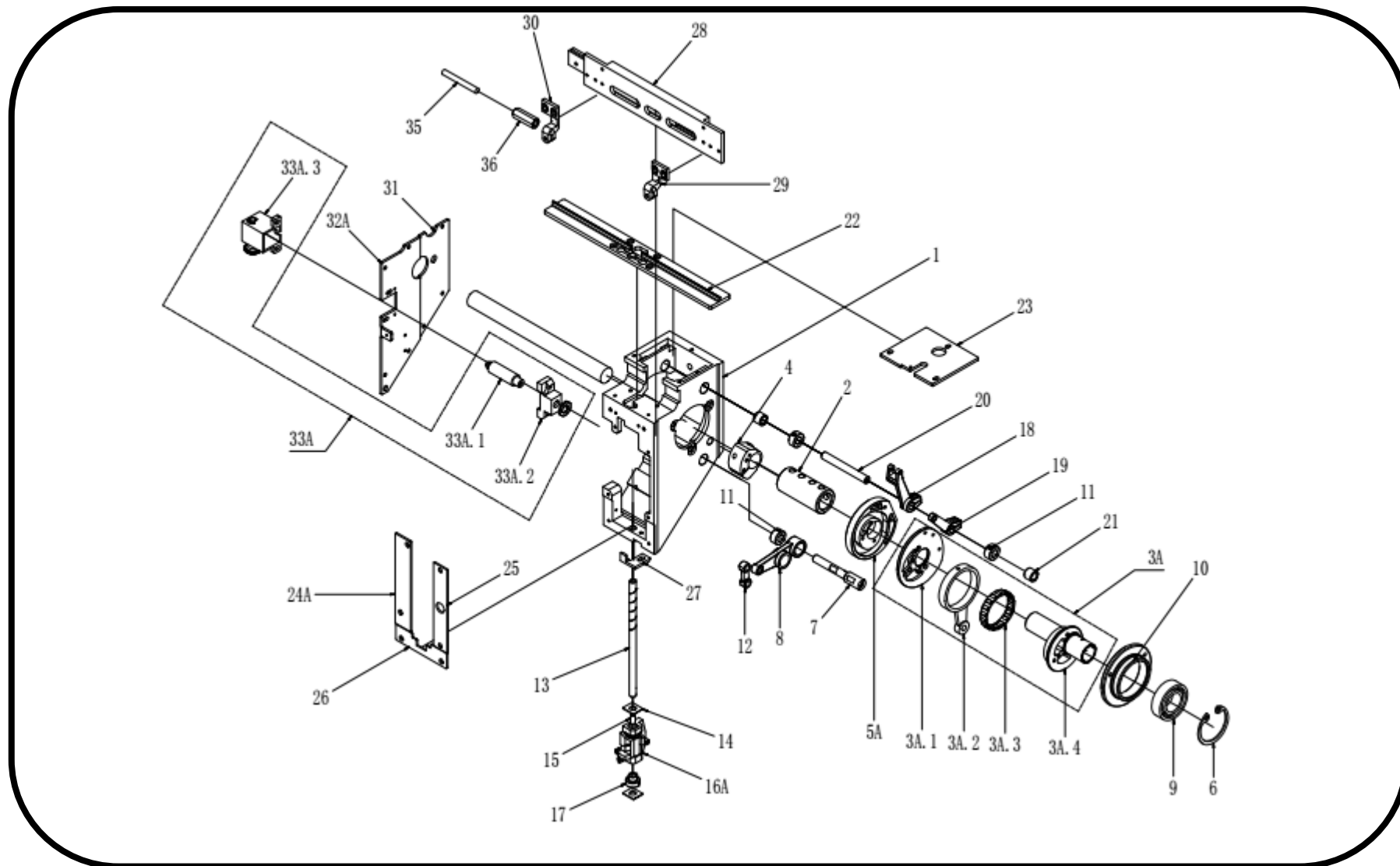

40050V1 机头系统总表一
40050V1. Machine Head System Table 1

指引号 Ref. No.	物料编码 Part No.	名称 Part Name		备注 Remark	指引号 Ref. No.	物料编码 Part No.	名称 Part Name		备注 Remark
1	4005010000	机头箱体	Arm box body		16A	01212080	针杆驱动器-高速- 电磁铁	Needle bar driver – high speed - electromagnet	
2	80031811	轴接套 Φ18-60	Coupling sleeveΦ18 -60		16B	01212061	针杆驱动器-高速- 电机	Needle bar driver – high speed -motor	
3A	01212461	单凸单驱套件 Φ18	Single convex and single drive kit Φ18		17	01202291	驱动轴轴环套件	Drive shaft collar kit	
3A. 1	400503A100	挡板	Baffle		18	01212165	挑线连杆组件 B	Take-up joint lever assmely B	
3A. 2	400503A200	连杆环	Connectin g rod ring		19	01212163	挑线连杆组件 A	Take-up joint lever assmely A	
3A. 3	400503A300	滚针轴承	Needle bearing		20	01212307	挑线连杆销轴 Φ8x65	Thread take-up connecting rodΦ8x65	
3A. 4	400503A400	凸轮	Cam		21	80030831	滚针轴承 8-12-8	Needle bearing 8-12- 8	
3B	01212462	双凸双驱套件 Φ18	Double convex double drive kitΦ18		22	400522** **	挑线杆导轨	Take-up rod rail	
3B. 1	400503B100	挡板	Baffle		23	40052300 00	机头上盖板-C 板	Arm upper cover plate– C plate	

40050V1 机头系统总表一
40050V1. Machine Head System Table 1

3B. 2	400503B200	连杆环	Connectin g rod ring		24A	01211008	机头前左盖板-电 磁铁	Arm front & left cover plate- electromagnet	
3B. 3	400503B300	滚针轴承	Needle bearing		24B	40052402 00	机头前左盖板-电 机锁头	Arm front & left cove plate- motor lock	
3B. 4	400503B400	凸轮	Cam		25	01211007	机头前右盖板	Arm front & right cover plate	
4	01212401	凸轮夹紧套-18	Cam clamping bushing		26	01211011	高速机头前下盖 板	High speed arm front & down cover plate	
5A	4005050100	挑线凸轮-单驱-18 轴	Take-up cam – single drive – 18 shaft		27	01210121	针杆架定位勾	Needle bar positioning hook	
5B	4005050000	挑线凸轮-双驱-18 轴	Take-up cam – double drive – 18 shaft		28	400528** **	珠架导轨	Bead frame rail	
6	80034781	内卡簧-47	Circlip - 47		29	01213130	换色支架夹头-右	Color change support clamping chuck - right	
7	01212303	三眼连杆销	Three- holes connectin g rod pin		30	01213131	换色支架夹头-左	Color change support clamping chuck - left	
8	01212161	三眼连杆组件	Three- holes connectin		31	01211009	机头 B 板	Arm plate B	

40050V1 机头系统总表一
40050V1. Machine Head System Table 1

			g assembly						
9	80032222	深沟球轴承 60/22	Deep groove ball bearing 60/22		32A	01211010	机头 A 板(电磁铁)	Arm plate A (electromagnet)	
10	4005100000	轴承座 60/22	Bearing base 60/22		32B	4005320200	机头 A 板(电机)	Arm plate A (motor)	
11	01202204	一眼挡圈	One-hold collar		33A	400533A000	跳跃电磁铁组件	Jumping electromagnet assembly	
12	01212109	小连杆	Small connecting rod		33. A1	80320201	跳跃电磁铁	Jumping electromagnet	
13	01212306	机头驱动轴	Arm driving shaft		33. A2	01212502	跳跃电磁铁座-高速	Jumping electromagnet base - high speed	
14	01212309	毛毡垫	Felt pad		33. A3	01202592	跳跃电磁铁罩壳	Jumping electromagnet cover	
15	4005150000	浸油棉条	Oil-immersed sliver		33B	400533B000	电机跳跃组件	Motor jumping assembly	

40050V1 机头系统总表二
40050V1. Machine Head System Table 2

指引号 Ref. No.	物料编 码 Part No.	名称 Part Name		备 注 Re mar k	指引号 Ref. No.	物料编码 Part No.	名称 Part Name	备注 Remark
33B. 1	803042 16	跳跃电机	Jumping motor					
33B. 2	400533 B020	跳跃电机安装板	Jumping mort mounting plate					
33B. 3	400533 B030	摆臂	Swing arm					
33B. 4	400533 B040	摆臂柱头	Swing arm chapter					
33B. 5	400533 B050	扭簧	Torsional spring					
33B. 6	400533 B060	扳手	Wrench					
33B. 7	400533 B070	扳手固定销	Wrench fixing pin					
33B. 8	400533 B080	扳手固定板	Wrench fixing plate					
33B. 9	400533 B090	限位臂	Limit arm					
33B. 10	010301 24	偏心胶	Eccentric glue					
34	400534 0000	压脚驱动组件	Presser drive assmebly					
34. 1	012122 60	压脚驱动块	Presser drive block					
34. 2	012121 62	压脚驱动连杆	Presser drive connecting rod					

40051V1 机头系统-双凸双驱电磁铁跳跃部分图

40051V1. Machine Head - Double convex and double drive Jumping Motor Diagram 1

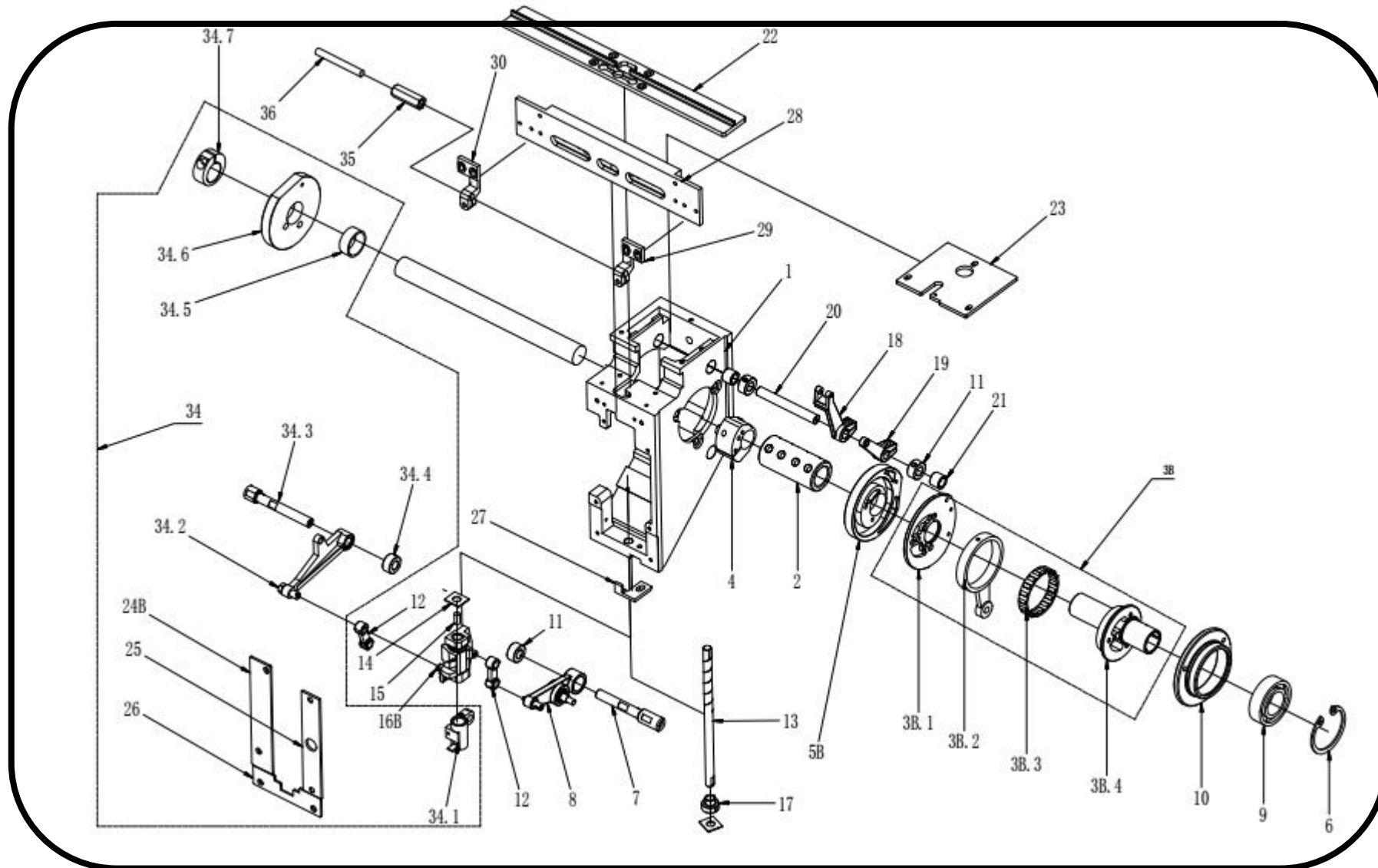

40051V1 机头系统-双凸双驱电磁铁跳跃部分图二
40050V1. Machine head - Double convex and double drive jumping motor diagram 2

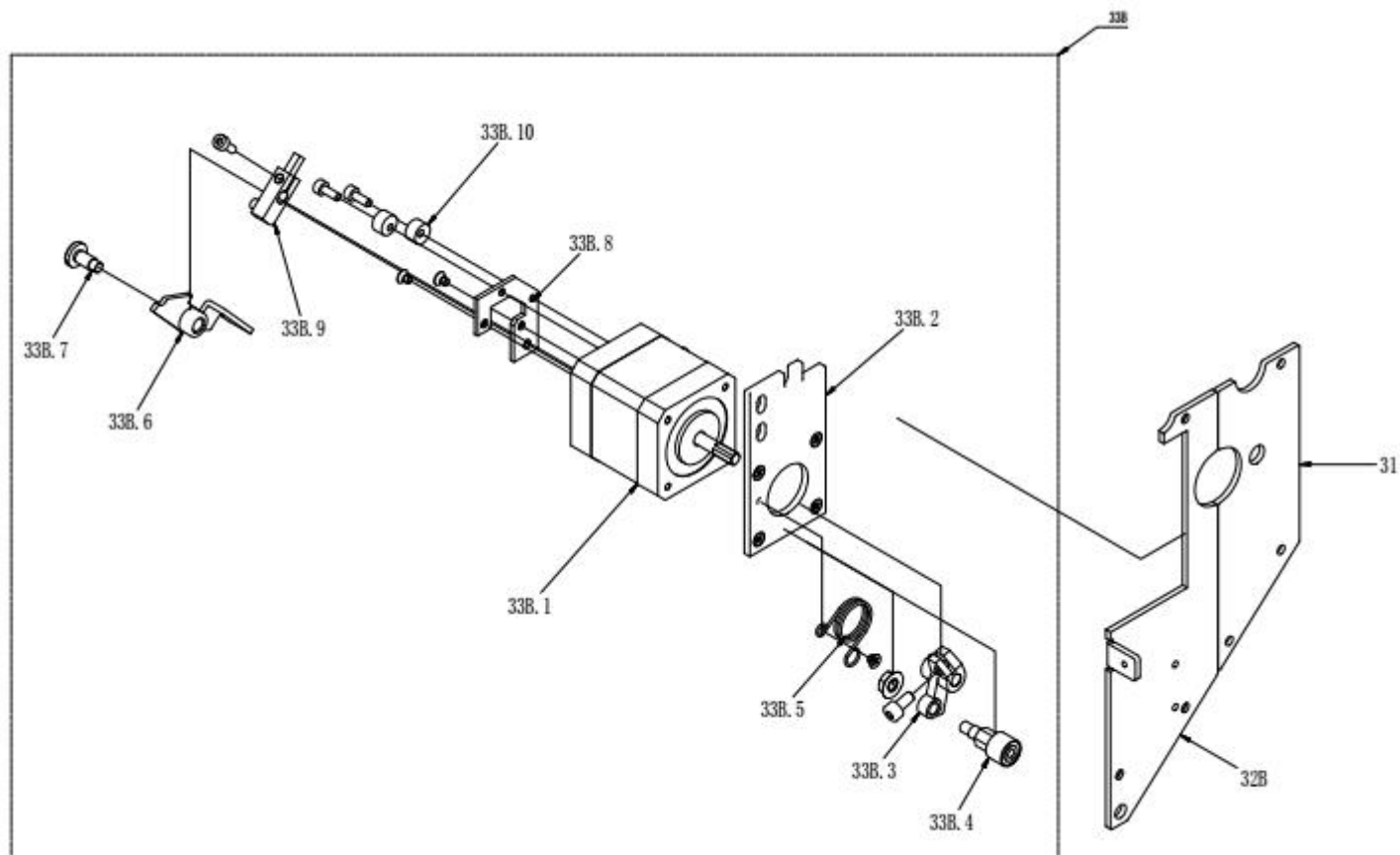

40051V1 机头系统总表一
40051V1. Machine Head System Table 1

指引号 Ref. No.	物料编码 Part No.	名称 Part Name		备注 Remark	指引号 Ref. No.	物料编码 Part No.	名称 Part Name		备注 Remark
1	4005010000	机头箱体	Arm box body		16A	01212080	针杆驱动器-高速-电磁铁	Needle bar driver – high speed - electromagn et	
2	80031811	轴接套 Φ18-60	Coupling sleeveΦ18- 60		16B	01212061	针杆驱动器-高速-电机	Needle bar driver – high speed - motor	
3A	01212461	单凸单驱套件 Φ18	Single convex and single drive kitΦ18		17	01202291	驱动轴轴环套件	Drive shaft collar kit	
3A.1	400503A100	挡板	Baffle		18	01212165	挑线连杆组件 B	Take-up joint lever assembly B	
3A.2	400503A200	连杆环	Connecting rod ring		19	01212163	挑线连杆组件 A	Take-up joint lever assembly A	
3A.3	400503A300	滚针轴承	Needle bearing		20	01212307	挑线连杆销轴 Φ8x65	Take-up connecting rod pin shaft Φ8x65	
3A.4	400503A400	凸轮	Cam		21	80030831	滚针轴承 8-12-8	Needle bearing 8- 12-8	
3B	01212462	双凸双驱套件 Φ18	Double convex double drive kitΦ18		22	400522****	挑线杆导轨	Take-up lever guide rail	
3B.1	400503B100	挡板	Baffle		23	4005230000	机头上盖板-C板	Arm upper	

40051V1 机头系统总表一
40051V1. Machine Head System Table 1

								cover plate- C plate	
3B. 2	400503B200	连杆环	Connecting rod ring		24A	01211008	机头前左盖板-电磁铁	Arm front & left cover plate- electromagn et	
3B. 3	400503B300	滚针轴承	Needle bearing		24B	4005240200	机头前左盖板-电机锁头	Arm front & left cove plate- motor lock	
3B. 4	400503B400	凸轮	Cam		25	01211007	机头前右盖板	Arm front & right cover plate	
4	01212401	凸轮夹紧套-18	Cam clamping bushing		26	01211011	高速机头前下盖板	High speed arm front & down cover plate	
5A	4005050100	挑线凸轮-单驱- 18 轴	Take-up cam – single drive – 18 shaft		27	01210121	针杆架定位勾	Needle bar positioning hook	
5B	4005050000	挑线凸轮-双驱- 18 轴	Take-up cam – double drive – 18 shaft		28	400528****	珠架导轨	Bead frame rail	
6	80034781	内卡簧-47	Circlip - 47		29	01213130	换色支架夹头-右	Color change support chuck - right	
7	01212303	三眼连杆销	Three-holes connecting rod pin		30	01213131	换色支架夹头-左	Color change support chuck - left	
8	01212161	三眼连杆组件	Three-holes connecting		31	01211009	机头 B 板	Arm plate B	

40051V1 机头系统总表一
40051V1. Machine Head System Table 1

			od assembly						
9	80032222	深沟球轴承 60/22	Deep groove ball bearing 60/22		32A	01211010	机头 A 板(电磁铁)	Arm plate A (electromag net)	
10	4005100000	轴承座 60/22	Bearing base 60/22		32B	4005320200	机头 A 板(电机)	Arm plat A (motor)	
11	01202204	一眼挡圈	One-hole collar		33A	400533A000	跳跃电磁铁组件	Jumping electromagn et assembly	
12	01212109	小连杆	Small connecting rod		33. A1	80320201	跳跃电磁铁	Jumping electromagn et	
13	01212306	机头驱动轴	Arm driving shaft		33. A2	01212502	跳跃电磁铁座-高速	Jumping electromagn et base - high speed	
14	01212309	毛毡垫	Felt pad		33. A3	01202592	跳跃电磁铁罩壳	Jumping electromagn et cover	
15	4005150000	浸油棉条	Oil- immersed sliver		33B	400533B000	电机跳跃组件	Motor jumping assembly	

40051V1 机头系统总表二
40051V1. Machine Head System Table 2

指引号 Ref. No.	物料编码 Part No.	名称 Part Name		备注 Remark	指引号 Ref. No.	物料编码 Part No.	名称 Part Name	备注 Remark
33B. 1	80304216	跳跃电机	Jumping motor					
33B. 2	400533B020	跳跃电机安装板	Jumping mort mounting plate					
33B. 3	400533B030	摆臂	Swing arm					
33B. 4	400533B040	摆臂柱头	Swing arm chapiter					
33B. 5	400533B050	扭簧	Torsional spring					
33B. 6	400533B060	扳手	Wrench					
33B. 7	400533B070	扳手固定销	Wrench fixing pin					
33B. 8	400533B080	扳手固定板	Wrench fixing plate					
33B. 9	400533B090	限位臂	Limit arm					
33B. 10	01030124	偏心胶	Eccentric glue					
34	4005340000	压脚驱动组件	Presser drive assembly					
34. 1	01212260	压脚驱动块	Presser drive block					
34. 2	01212162	压脚驱动连杆	Presser drive connecting rod					
34. 3	01212111	压脚驱动销轴	Presser driver pin roll					
34. 4	01212308	半眼挡圈	Half-hole collar					
34. 5	4005340500	压脚凸轮间隔圈 -Φ18 轴	Presser cam space collar -Φ18 shaft					

40060V1 针杆架系统-整体式压脚部分图
40060V1. Needle bar case System – Integral Presser Diagram

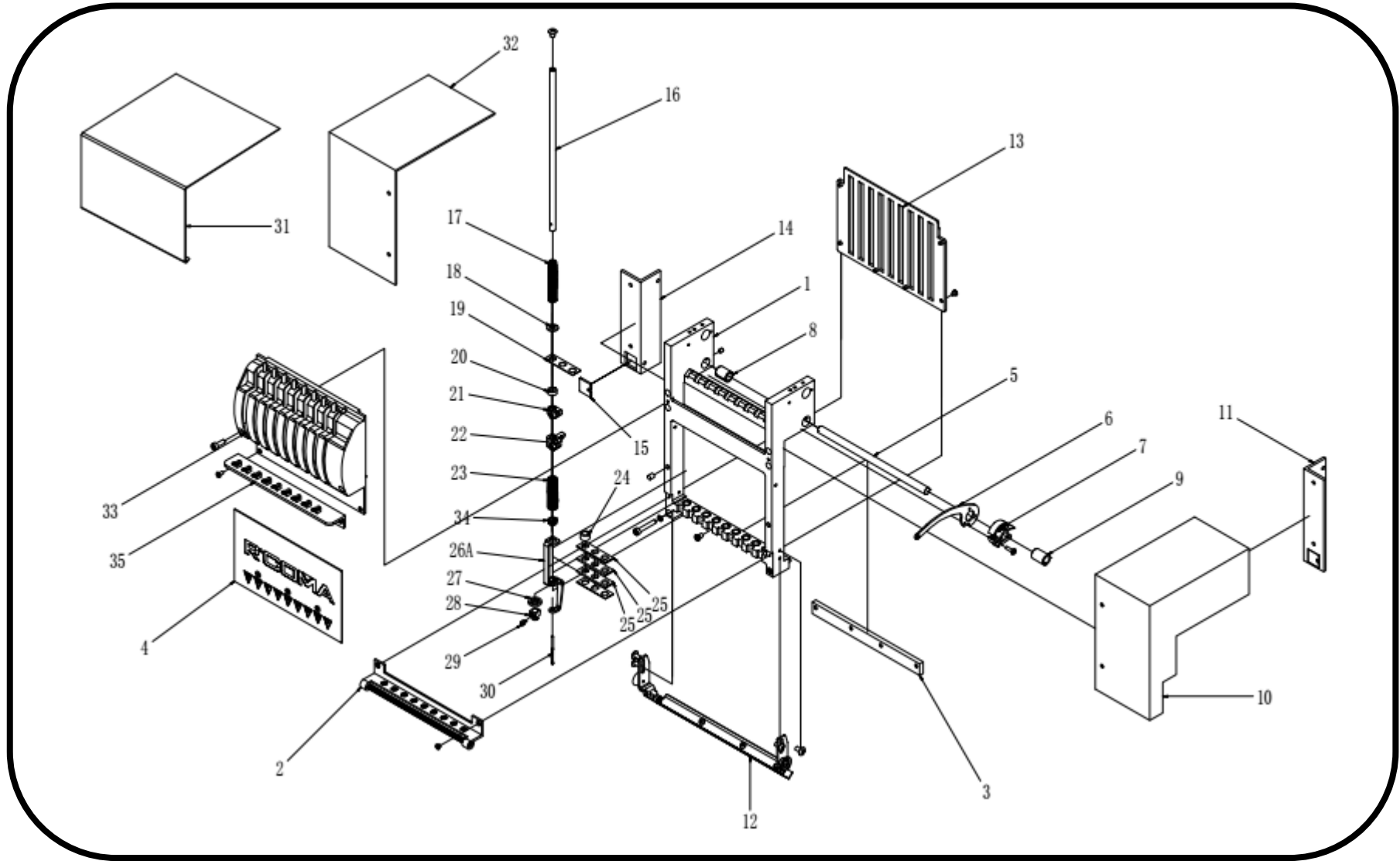

40060V1 针杆架系统总表
40060V1. Needle bar case System General Table

指引号 Ref. No.	物料编码 Part No.	名称 Part Name		备注 Remark	指引号 Ref. No.	物料编码 Part No.	名称 Part Name		备注 Remark
1	400601****	针杆架	Needle bar case		26A	400626A000	整体式压脚	Integral presser	
2	400602****	下过线	Lower thread cross		26B	400626B000	分体式压脚	Split presser	
3	400603****	下导轨	Lower rail		26B. 1	03080181	压脚体	Presser body	
4	400604****	下面板	Lower panel		26B. 2	03080104AA	压脚胶套	Presser rubber cover	
5	400605****	挑线杆轴	Take-up lever shaft		27	01222110	O 型圈	O-shape ring	
6	4006060000	挑线杆	Take-up lever		28	01222181	针夹头	Needle clamping chuck	
7	4006070000	挑线杆齿	Take-up lever tooth		29	01222183	针夹螺丝	Needle clamping screw	
8	03081505	挑线轴挡块-12	Take-up shaft block - 12		30	806211**	机针-DBXK5	Machine needle - DBXK5	
9	03081506	挑线轴挡块-15	Take-up shaft block - 15		31	600631****	针杆架插板	Needle bar case inserter	
10	4006100000	针杆架右罩壳	Needle bar case right cover		32	4006320000	针杆架左罩壳	Needle bar case left cover	
11	4006110000	针杆架磁铁座-右	Needle bar case magnet base - right		33	80210221—*	上面板	Upper panel	
12	4006120400	面线夹组件	Face thread clamp assembly		34	4006340000	压脚弹簧胶圈	Presser spring rubber ring	

40060V1 针杆架系统总表
40060V1. Needle bar case System General Table

13	4006130400	针杆导向板	Needle bar guide plate		35	400635****	中过线	Thread middle cross plate	
14	4006140000	针杆架磁铁座-左	Needle bar case magnet base - left						
15	4006150000	强力磁铁	Strong magnet						
16	03080195	针杆-带螺丝	Needle bar - with screw						
17	03080102	针杆弹簧	Needle bar spring						
18	80900603	平垫	Flat pad						
19	01221606	三孔毛毡垫-1	Three-holes felt pad -1						
20	4006200000	橡胶 O 型圈	Rubber O-shape ring						
21	01222105	上死点卡头	Upper dead point stopper						
22	01222106	下死点卡头	Needle bar connecting stud						
23	03080108	压脚弹簧	Presser spring						
24	4006240000	压脚缓冲垫	Presser cushion pad						
25	400625****	牛津垫	Oxford pad						

40061V1 针杆架系统-分体式压脚部分图
40061V1. Needle bar case System – Integral Presser Diagram

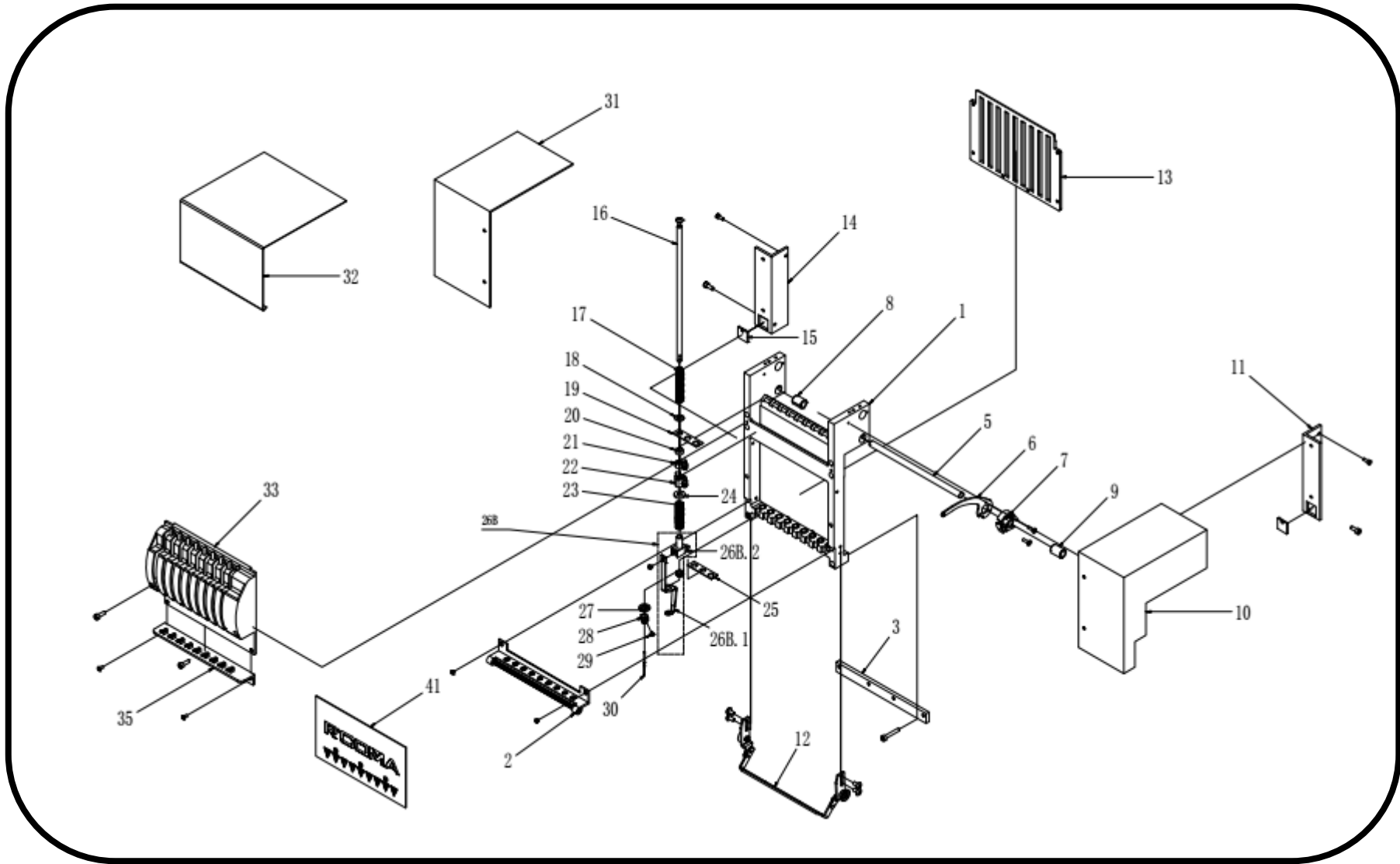

40061V1 针杆架系统总表
40061V1. Needle bar case System General Table

指引号 Ref. No.	物料编码 Part No.	名称 Part Name		备注 Remark	指引号 Ref. No.	物料编码 Part No.	名称 Part Name		备注 Remark
1	400601*** *	针杆架	Needle bar case		26A	400626A000	整体式压脚	Integral presser	
2	400602*** *	下过线	Lower thread cross		26B	400626B000	分体式压脚	Split presser	
3	400603*** *	下导轨	Lower rail		26B. 1	03080181	压脚体	Presser body	
4	400604*** *	下面板	Lower panel		26B. 2	03080104AA	压脚胶套	Presser rubber cover	
5	400605*** *	挑线杆轴	Take-up lever shaft		27	01222110	O 型圈	O-shape ring	
6	400606000 0	挑线杆	Take-up lever		28	01222181	针夹头	Needle chuck	
7	400607000 0	挑线杆齿	Take-up lever tooth		29	01222183	针夹螺丝	Needle chuck screw	
8	03081505	挑线轴挡块-12	Take-up shaft block – 12		30	806211**	机针-DBXK5	Machine needle – DBXK5	
9	03081506	挑线轴挡块-15	Take-up shaft block – 15		31	600631****	针杆架插板	Needle bar case inserter	
10	400610000 0	针杆架右罩壳	Needle bar case right cover		32	4006320000	针杆架左罩壳	Needle bar case left cover	
11	400611000 0	针杆架磁铁座- 右	Needle bar case		33	80210221—*	上面板	Upper panel	

40061V1 针杆架系统总表
40061V1. Needle bar case System General Table

			magnet base - right						
12	4006120400	面线夹组件	Face thread clamp assembly		34	4006340000	压脚弹簧胶圈	Presser spring rubber ring	
13	4006130400	针杆导向板	Needle bar guide plate		35	400635****	中过线	Thread middle cross plate	
14	4006140000	针杆架磁铁座-左	Needle bar case magnet base - left						
15	4006150000	强力磁铁	Strong magnet						
16	03080195	针杆-带螺丝	Needle bar - with screw						
17	03080102	针杆弹簧	Needle bar spring						
18	80900603	平垫	Flat pad						
19	01221606	三孔毛毡垫-1	Three-holes felt pad -1						
20	4006200000	橡胶 O 型圈	Rubber O-shape ring						
21	01222105	上死点卡头	Upper dead						

40061V1 针杆架系统总表
40061V1. Needle bar case System General Table

			point stopper						
22	01222106	下死点卡头	Needle bar connecting stud						
23	03080108	压脚弹簧	Presser spring						
24	4006240000	压脚缓冲垫	Presser cushion pad						
25	012216**	牛津垫	Oxford pad						

40070V1 换色系统-交流换色部分图

40070V1. Color Change System – Alternating Color Change Diagram

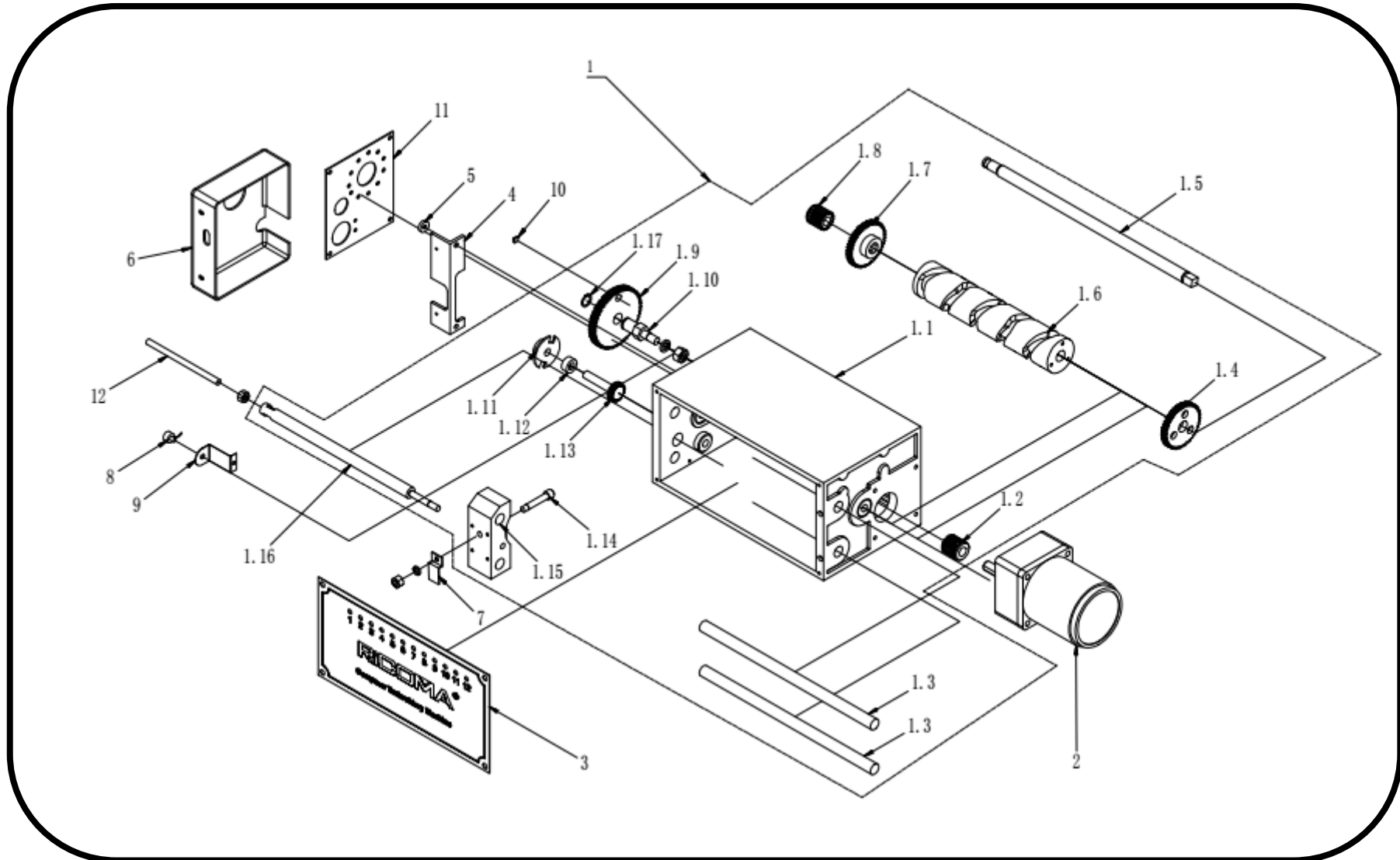

40070V1 换色系统-交流换色部分表
40070V1.Color Change System – Alternating Color Change Table

指引号 Ref. No.	物料编码 Part No.	名称 Part Name		备注 Remark	指引号 Ref. No.	物料编码 Part No.	名称 Part Name		备注 Remark
1	40070101* *	交流换色箱组件	Alternating color change box assembly		10	4007100000	针位感应磁钢	Needle position inductive magnetic steel	
1.1	40070101* *01	交流换色箱体	Alternating color change box body		11	400711****	针位板	Needle position plate	
1.2	400701010 002	电机传动齿轮	Motor transmission gear		12	80030601	换色拉杆 φ6	Color change pull-rod φ6	
1.3	40070101* *03	导向轴	Guiding shaft						
1.4	400701010 004	换色凸轮传动齿轮 A	Color change cam transmission gear A						
1.5	40070101* *05	换色凸轮轴	Color change camshaft						
1.6	40070101* *06	换色凸轮	Color change cam						
1.7	400701010 007	换色凸轮传动齿轮 B	Color change cam transmission gear B						
1.8	400701010	感应磁钢调节齿轮	Inductive magnetic						

40070V1 换色系统-交流换色部分表

40070V1.Color Change System – Alternating Color Change Table

	008		steel adjusting gear						
1. 9	400701010 009	感应磁钢安装齿轮	Inductive magnetic steel mounting gear						
1. 10	400701010 010	齿轮柱头	Gear chapter						
1. 11	400701010 011	半回转遮光轮	Semi rotary light shielding wheel						
1. 12	400701010 012	挡圈	Collar						
1. 13	400701010 013	遮光轮传动齿	Light shielding transmissi on gear						
1. 14	400701010 014	换色驱动柱头	Color change drive chapter						
1. 15	400701010 015	换色轴座	Color change shaft base						
1. 16	40070101* *16	换色轴	Color change shaft						
1. 17	400701010 017	轴卡	STW						
2	80320101	交流换色电机	Alternatin						

40070V1 换色系统-交流换色部分表
40070V1.Color Change System – Alternating Color Change Table

			g color change motor						
3	40070301* *	换色箱面板	Color change panel						
4	01291208	罩盖支架	Cover support						
5	400705000 0	绝缘垫圈	Insulating washer						
6	80211002	换色箱盖罩	Color change cover						
7	01290912	换色指示贴片	Color change indicating sticker						
8	80333702	换色电位器	Color change potentiometer						
9	01291210	换色传感器安装板	Color change sensor mounting plate						

40071V1 换色系统-步进丝杠换色部分图
40071V1.Color Change System – Step and Screw Color Change diagram

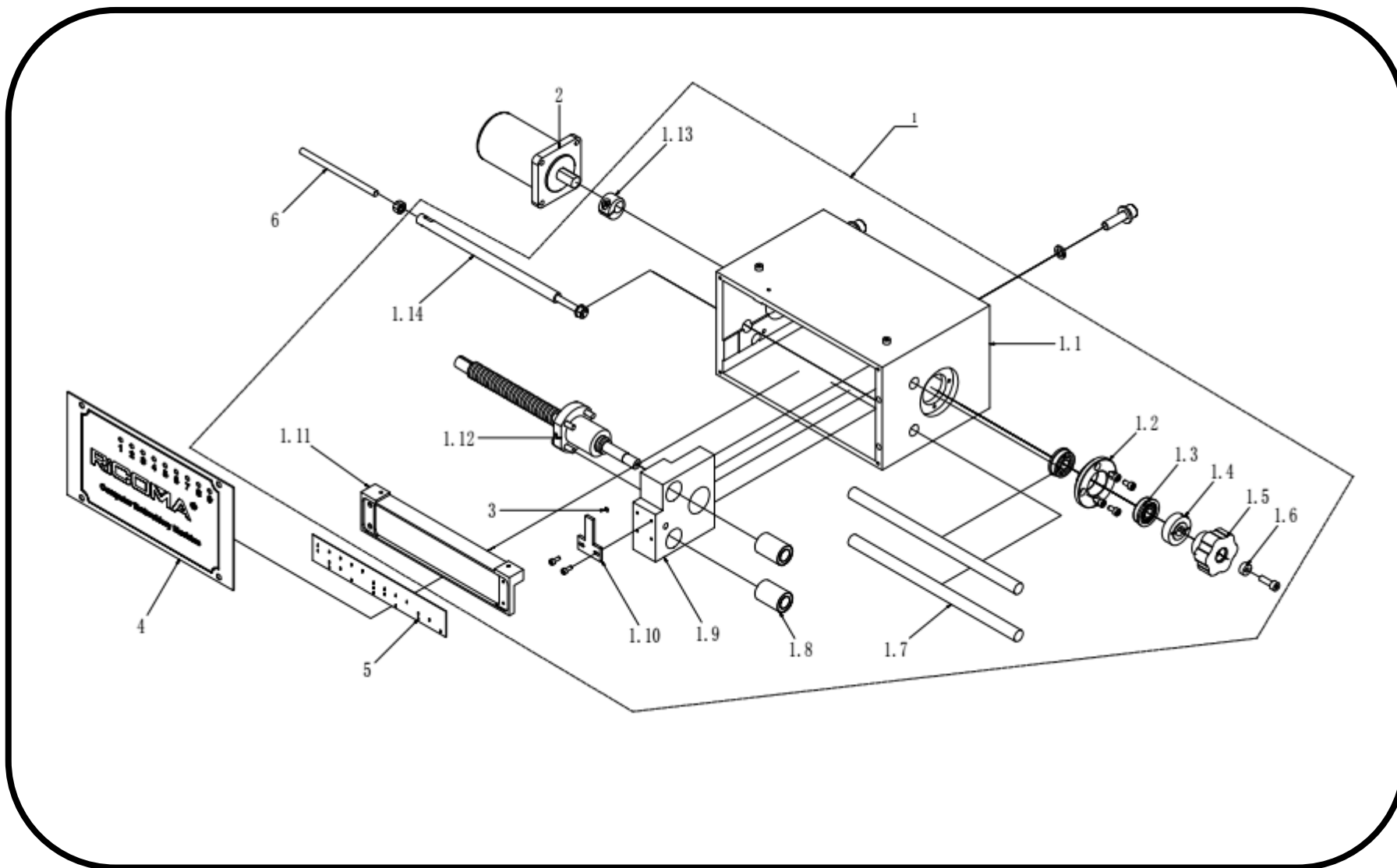

40071V1 换色系统-步进丝杠换色部分表
40071V1.Color Change System – Step and Screw Color Change Table

指引号 Ref. No.	物料编码 Part No.	名称 Part Name		备注 Remark	指引号 Ref. No.	物料编码 Part No.	名称 Part Name	备注 Remark
1	40070102**	步进丝杠换色箱组件	Step and screw color change box assembly					
1.1	40070102**01	步进丝杠换色箱体	Step and screw color change box body					
1.2	40070102002	F6000Z 轴承座	F6000Z bearing base					
1.3	40070102003	F6000Z 轴承	F6000Z bearing					
1.4	40070102004	丝杠间隙调节圈	Screw gap adjusting ring					
1.5	40070102005	旋钮	Knob					
1.6	40070102006	螺丝垫圈	Screw gasket					
1.7	40070102**07	导向轴	Guiding shaft					
1.8	40070102008	LM12UU 轴承	LM12UU bearing					
1.9	40070102009	换色轴座	Color change bearing base					
1.10	40070102010	感应磁钢支架	Inductive magnetic steel support					
1.11	40070102**11	针位板支架	Needle position plate support					
1.12	40070102**12	丝杠	Screw					
1.13	400701020013	电机轴紧固圈	Motor shaft fastening ring					
1.14	40070102**14	换色轴	Color change					

40080V1 剪线系统-电磁铁剪线部分图

40080V1. Trimming System – Electromagnet Trimming Diagram

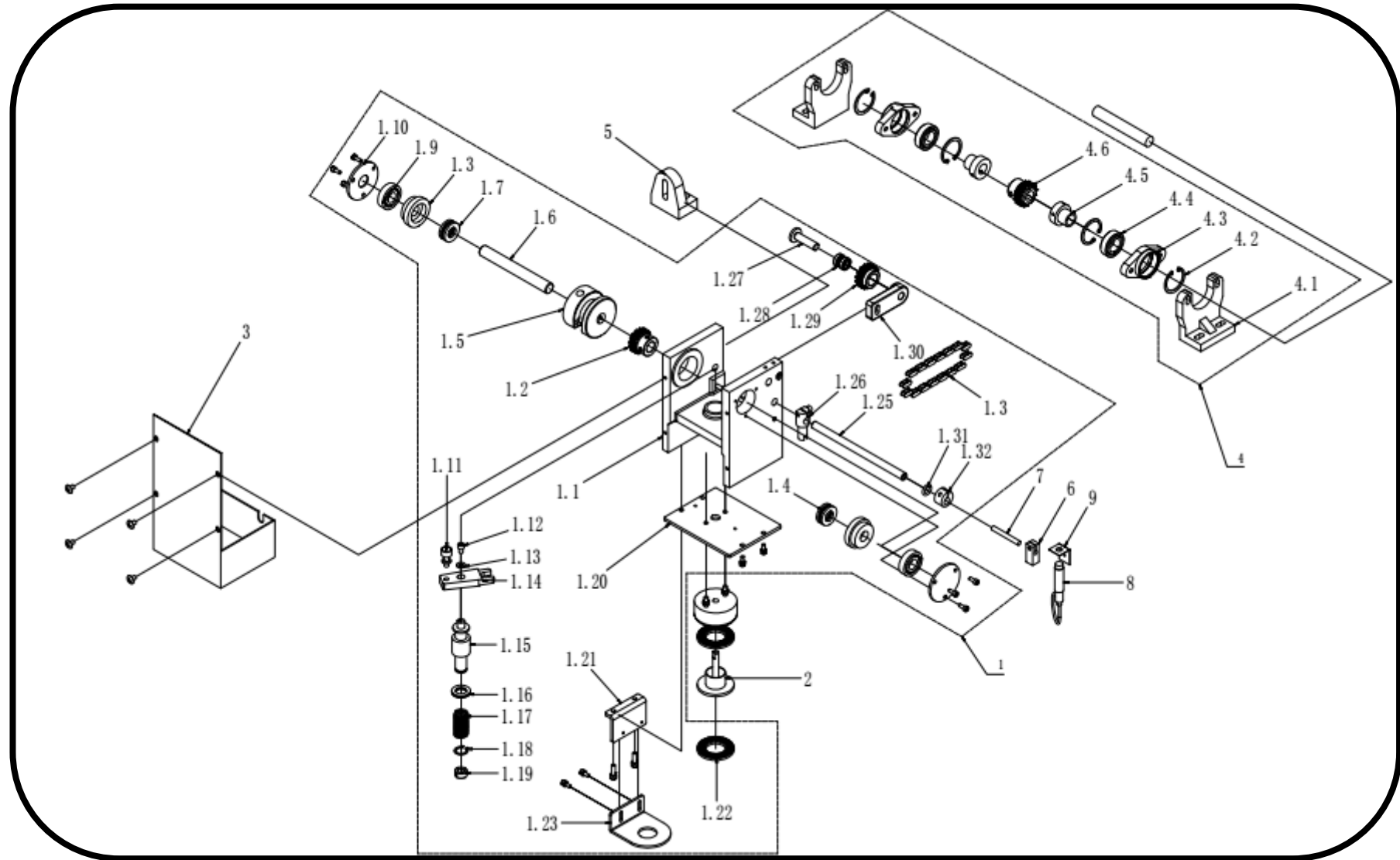

40080V1 剪线系统-电磁铁剪线部分表
40080V1. Trimming System – Electromagnet Trimming Table

指引号 Ref. No.	物料编码 Part No.	名称 Part Name		备注 Remark	指引号 Ref. No.	物料编码 Part No.	名称 Part Name		备注 Remark
1	01400661	电磁铁剪线箱组件	Electromagnetic trimming box assembly		1. 26	4008010126	夹紧柱头	Clamp chapter	
1. 1	4008010101	电磁铁剪线箱体	Electromagnetic trimming box body		1. 27	4008010127	张紧齿轮销	Tension gear pin	
1. 2	4008010102	剪线驱动齿轮 A	Trimming drive gear A		1. 28	4008010128	滚针轴承	Needle bearing	
1. 3	4008010103	剪线驱动链条	Trimming drive chain		1. 29	4008010129	张紧齿轮	Tension gear	
1. 4	4008010104	间隔圈	Space collar		1. 30	4008010130	张紧支架	Tension support	
1. 5	4008010105	剪线驱动凸轮	Trimming drive cam		1. 31	400801020010	剪线轴胶圈	Trimming shaft rubber ring	
1. 6	4008010106	凸轮轴	Camshaft		1. 32	400801020011	限位夹紧套	Limit clamping bushing	
1. 7	4008010107	推力球轴承	Thrust ball bearing		2	80320207	剪线电磁铁	Trimming electromagnet	
1. 8	4008010108	推力球轴承座	Thrust ball bearing base		3	4008030100	剪线箱罩盖	Trimming box cover	
1. 9	4008010109	6202Z 轴承	6202Z bearing		4	4008040000	剪线轴承组件	Trimming bearing assembly	
1. 10	4008010110	轴承挡板	Bearing baffle		4. 1	4008040100	剪线轴承支架	Trimming bearing support	
1. 11	4008010111	剪线驱动柱头	Trimming drive chapter		4. 2	4008040200	卡簧	Circlip	

40080V1 剪线系统-电磁铁剪线部分表
40080V1. Trimming System – Electromagnet Trimming Table

1. 12	400801011 2	摆杆固定销	Swing rod fixing pin		4. 3	4008040300	轴承座	Bearing base	
1. 13	400801011 3	固定销垫片	Fixing pin gasket		4. 4	80031722	6003 轴承	6003 Bearing	
1. 14	400801011 4	剪线驱动摆杆	Trimming drive swing rod		4. 5	80031501	6003 轴承内套 φ15	6003 Bearing housingφ15	
1. 15	400801011 5	摆杆顶柱	Swing rod top pillar		4. 6	4008040600	剪线时间调节齿轮	Trimming time adjusting gear	
1. 16	400801011 6	摆杆胶圈	Swing rod rubber ring		5	4008050000	剪线箱支架	Trimming box support	
1. 17	400801011 7	摆杆复位弹簧	Swing rod reset spring		6	01221401	感应铁块	Inductive iron block	
1. 18	400801011 8	轴卡	STW		7	80030601	拉杆 φ6	Pull rodφ6	
1. 19	400801011 9	挡圈	Collar		8	80333602	接近开关	Proximity switch	
1. 20	400801012 0	电磁铁安装底板	Electromagneti c mounting plate		9	01400105	接近开关固定支架	Proximity switch fixing support	
1. 21	400801012 1	电磁铁托板支架	Electromagneti c plate support						
1. 22	400801012 2	电磁铁缓冲垫	Electromagneti c cushion pad						
1. 23	400801012 3	电磁铁托板	Electromagneti c plate						
1. 24	400801012 4	导向轴	Guild bearing						
1. 25	400801012 5	剪线驱动轴	Trimming drive shaft						

40081V1 剪线系统-步进电机剪线部分图
40081V1. Trimming System –Step Motor Trimming Diagram

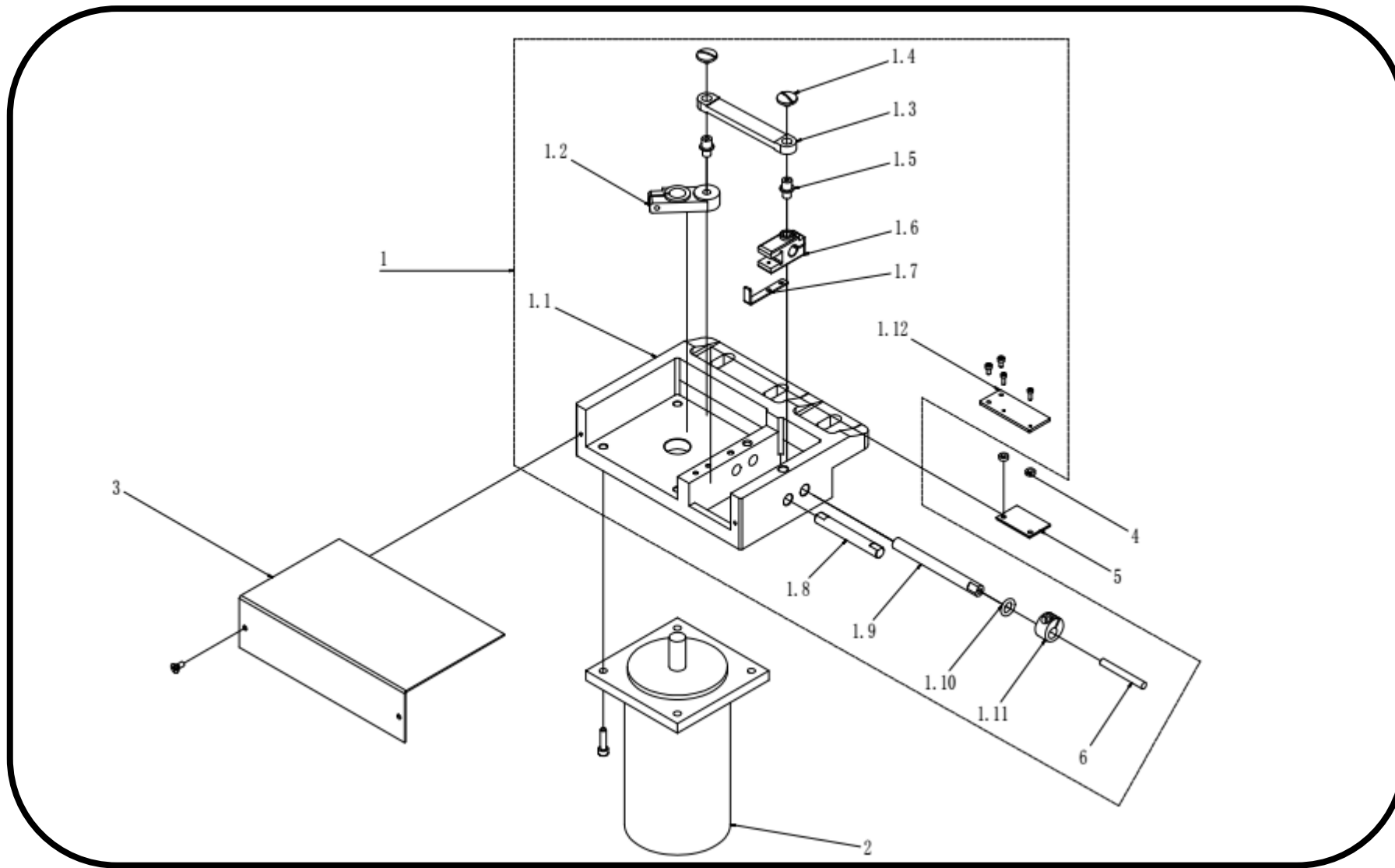

40081V1 剪线系统-步进电机剪线部分表
40081V1. Trimming System –Step Motor Trimming Table

指引号 Ref. No.	物料编码 Part No.	名称 Part Name		备注 Remark	指引号 Ref. No.	物料编码 Part No.	名称 Part Name	备注 Remark
1	40080102**	步进电机剪线箱组件	Step motor trimming box assembly					
1.1	40080102**01	步进电机剪线箱体	Step motor trimming box body					
1.2	40080102**02	剪线摆杆	Trimming swing rod					
1.3	40080102**03	剪线驱动连杆	Trimming drive connecting rod					
1.4	400801020004	连杆螺钉	Rod screw					
1.5	400801020005	连杆柱头	Connecting rod chapiter					
1.6	400801020006	驱动轴锁块	Drive shaft locking sheet					
1.7	400801020007	检测铁片	Detection iron sheet					
1.8	400801020008	导向轴	Guiding shaft					
1.9	400801020009	驱动轴	Drive shaft					
1.10	400801020010	胶圈	Rubber ring					
1.11	400801020011	限位夹紧套	Limit clamp bushing					

40090V1 勾线系统-交流集中勾线部分图
40090V1. Hooking System –Alternating Centralized hooking Diagram

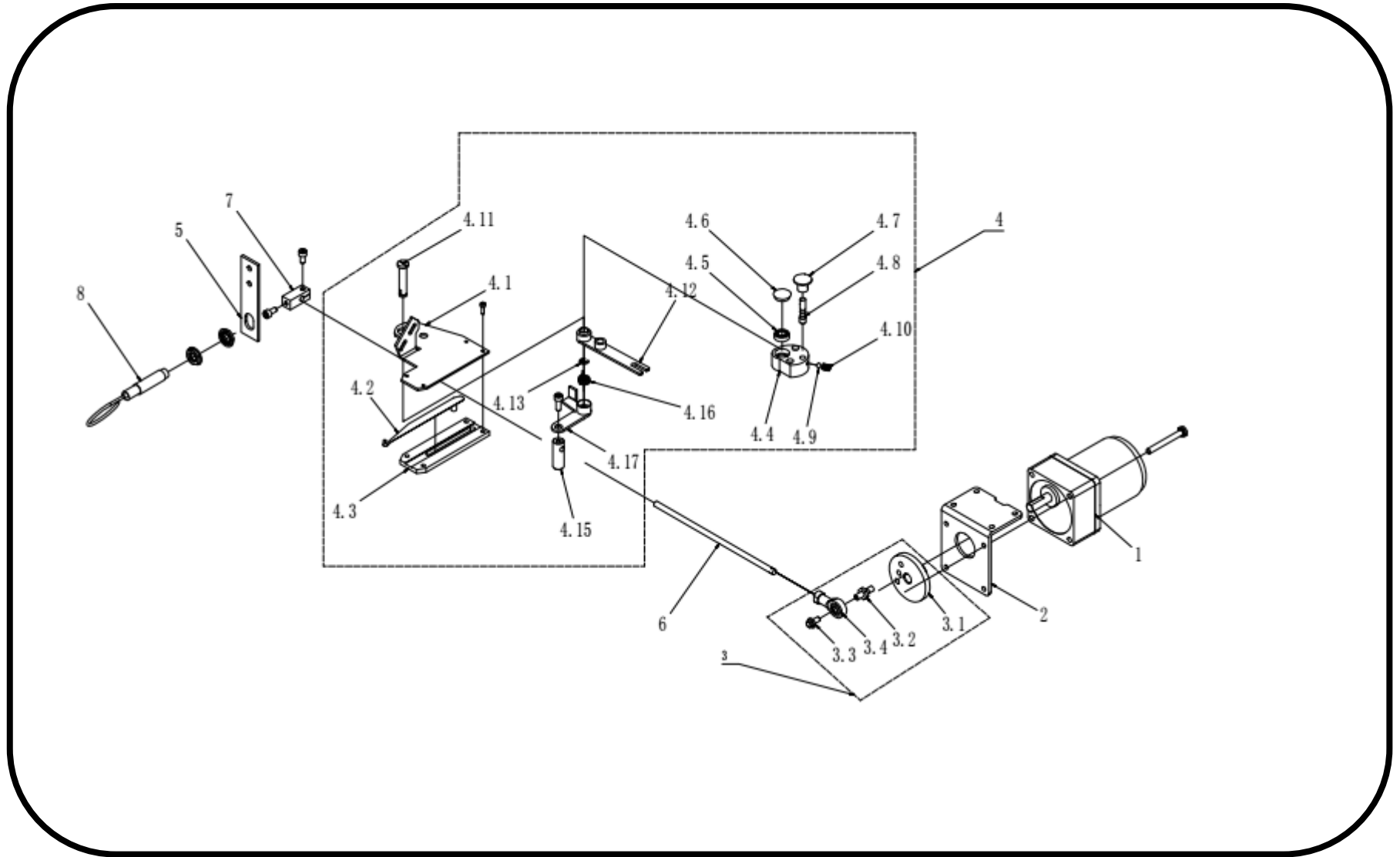

40090V1 勾线系统-交流集中勾线部分表
40090V1.Hooking System –Alternating Centralized hooking Table

指引号 Ref. No.	物料编码 Part No.	名称 Part Name		备注 Remark	指引号 Ref. No.	物料编码 Part No.	名称 Part Name		备注 Remark
1	80320111	勾线交流电机	Hooking AC motor		6	80030601	拉杆 φ6	Pull rodφ6	
2	01431111	勾线电机座	Hooking motor base		7	01221401	感应铁块	Inductive iron block	
3	4009030000	勾线凸轮组件	Hooking cam assembly		8	80333602	圆柱接近开关 NPN	Column proximity switch NPN	
3.1	4009030100	勾线凸轮	Hooking cam						
3.2	4009030200	连杆销	Connecting rod pin						
3.3	4009030300	连杆销螺钉	Connecting rod pin screw						
3.4	4009030400	勾线连杆	Hook connecting rod						
4	4009040000	勾刀组件	Hooking knife assembly						
4.1	4009040100	勾刀底板	Hooking knife plate						
4.2	4009040200	勾刀	Hooking knife						
4.3	4009040300	勾刀盖板	Hooking cover plate						
4.4	4009040400	勾刀锁座	Hooking knife lock bracket						
4.5	4009040500	轴承	Bearing						

40090V1 勾线系统-交流集中勾线部分表
40090V1.Hooking System –Alternating Centralized hooking Table

4. 6	4009040600	轴承盖	Bearing cover						
4. 7	4009040700	拉头	Puller						
4. 8	4009040800	卡柱	Check column						
4. 9	4009040900	滚珠	Ball						
4. 10	4009041000	滚珠复位簧	Ball reset spring						
4. 11	4009041100	柱头	Chapiter						
4. 12	4009041200	摆杆	Swing rod						
4. 13	4009041300	轴卡	STW						
4. 14	4009041400	螺钉	Screw						
4. 15	4009041500	连杆固定柱	Connecting rod fixingleg						
4. 16	4009041600	扭簧	Torsional spring						
4. 17	4009041700	摆杆支架	Swing rod support						
5	01430507	勾线接近开关支架	Hooking proximity switch bracket						

40100V1X 向驱动系统-步进电机驱动部分图

40100V1. X Drive system – Step motor drive diagram

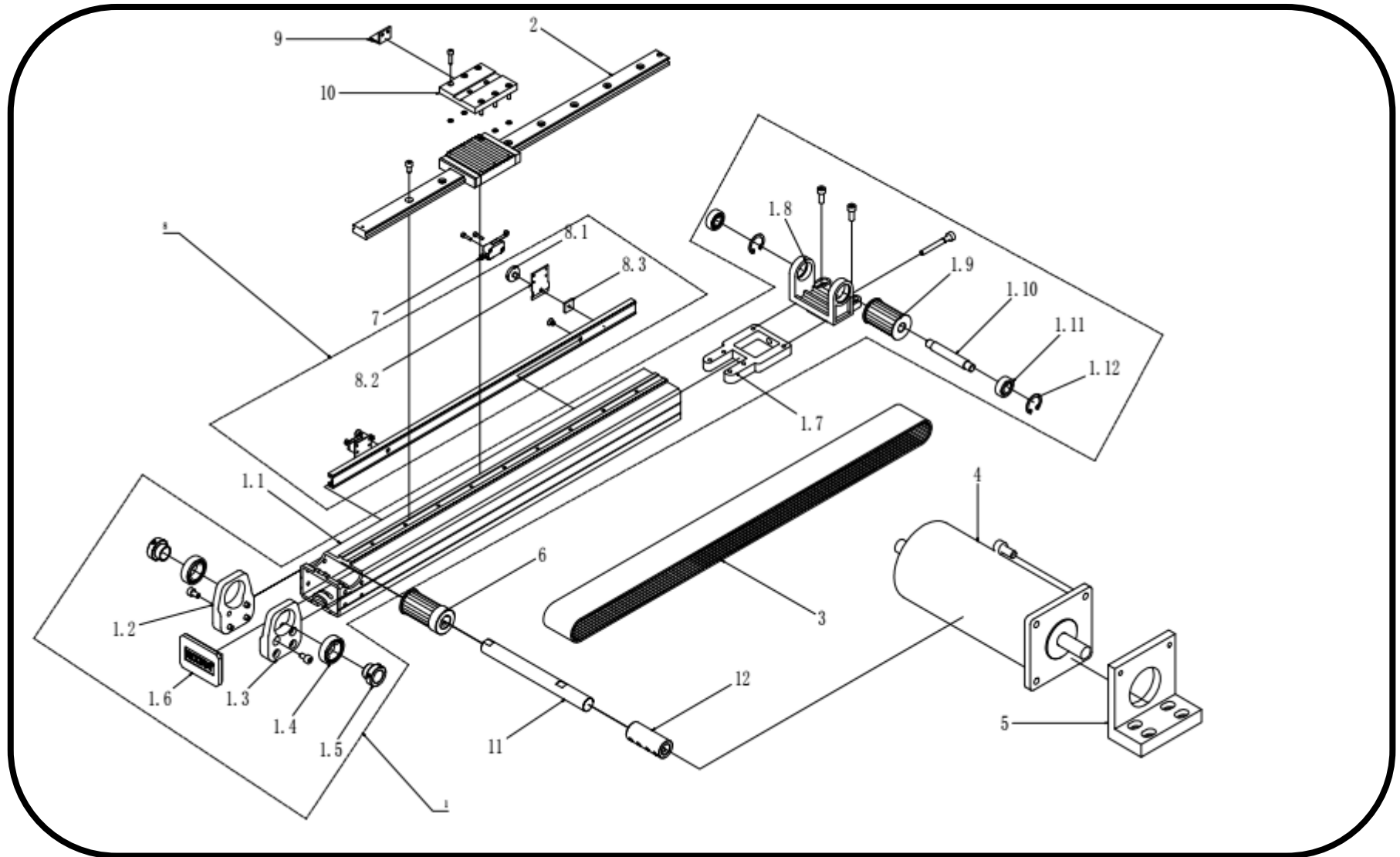

40100V1X 向驱动系统-步进电机驱动部分表

40100V1. X Drive System – Step Motor Drive Table

指引号 Ref. No.	物料编码 Part No.	名称 Part Name		备注 Remark	指引号 Ref. No.	物料编码 Part No.	名称 Part Name		备注 Remark
1	401001****	驱动导轨座组件-X***	Drive guide rail base assembly - X***		10	4010100000	皮带压板 X 向	Belt pressing plate – X direction	
1.1	401001****01	X 驱动座	X drive base		11	80031851-4000	光轴 18-4000	Optical axis 18-4000	
1.2	401001000002	驱动轴承座左	Drive bearing base left		12	80031811BA	连轴套 Φ18 抱紧式	Coupling shaft busing Φ18 tight	
1.3	401001000003	驱动轴承座右	Drive bearing base right						
1.4	401001000004	6904 轴承	6904 Bearing						
1.5	401001000005	轴承内套	Bearing inner bush						
1.6	401001000006	驱动座盖	Drive base cover						
1.7	401001000007	张紧轮底座	Tension pulley base						
1.8	401001000008	张紧轮支架	Tension pulley support						
1.9	401001000009	张紧轮	Tension pulley						
1.10	401001000010	张紧轮轴	Tension pulley shaft						

40100V1X 向驱动系统-步进电机驱动部分表

40100V1. X Drive System – Step Motor Drive Table

1. 11	80031022	6000 轴承	6000 Bearing						
1. 12	40100100001 2	卡簧	Circlip						
2	401002****	直线导轨组件	Linear guide rail assembly						
3	80025185BA	驱动皮带 HTD5M-50	Drive belt HTD5M-50						
4	40100401**	步进电机	Step motor						
5	01110802	步进电机座-X110	Step motor base – X110						
6	4010060000	主动带轮-HTD5M-20 齿-50 宽	Driving pulley - HTD5M-20 gear – 50 width						
7	80351101	限位开关	Limit switch						
8	401008****	限位开关安装板组件	Limit switch mounting plate assembly						
8. 1	4010080100	固定螺钉	Fixing screw						
8. 2	4010080200	限位开关支架	Limit switch bracket						
8. 3	4010080300	固定块	Fixed block						
8. 4	4010080400	调节卡槽	Adjusting						

40100V1X 向驱动系统-步进电机驱动部分表
40100V1. X Drive System – Step Motor Drive Table

			slot						
9	4010090000	触动支架	Touch support						

40101V1X 向驱动系统-伺服电机驱动部分图
40101V1. X Drive system –Servo Motor Drive Diagram

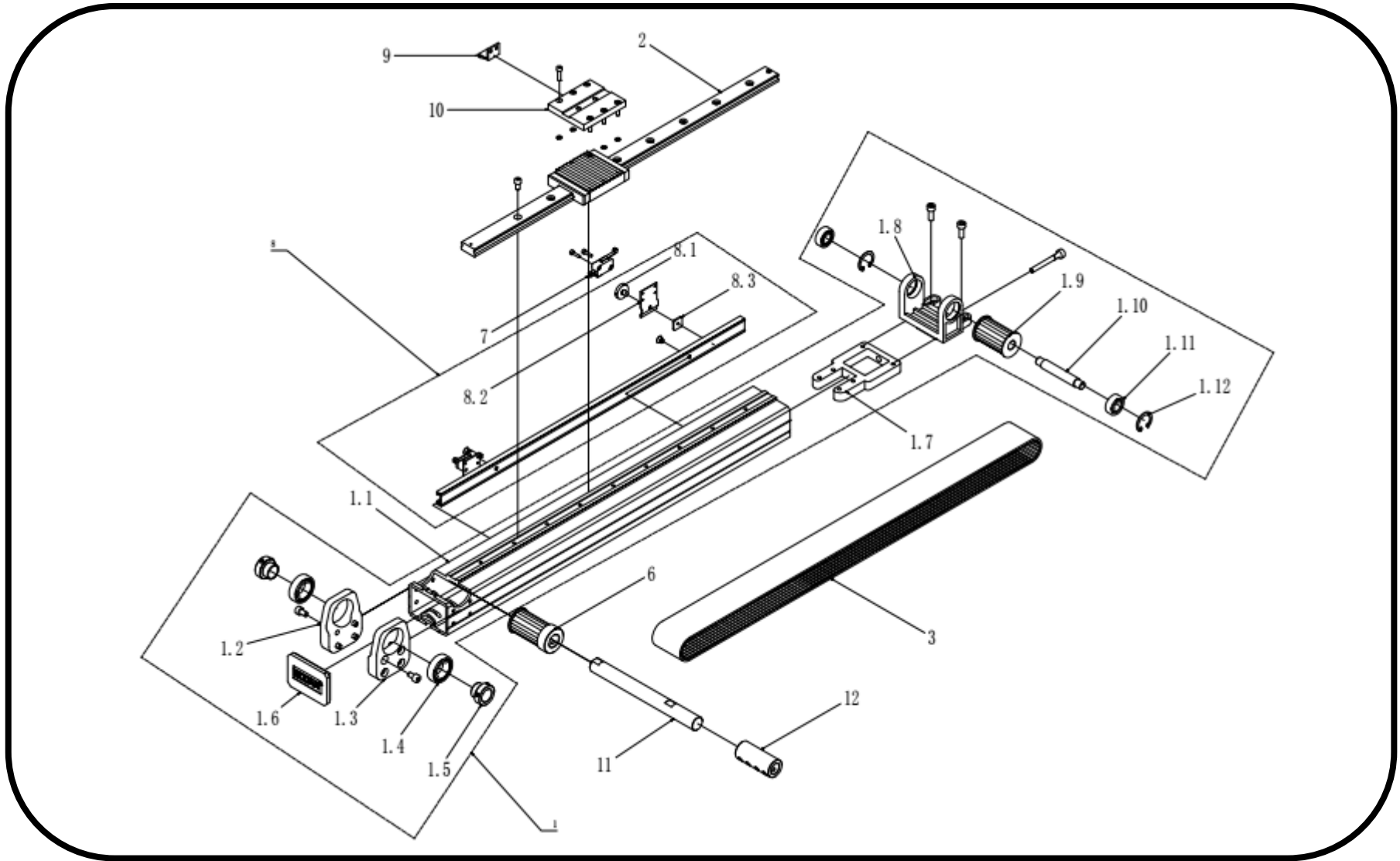

40101V1X 向驱动系统-伺服电机驱动部分表

40101V1. X Drive System –Servo Motor Drive Table

指引号 Ref. No.	物料编码 Part No.	名称 Part Name		备注 Remark	指引号 Ref. No.	物料编码 Part No.	名称 Part Name		备注 Remark
1	401001** **	驱动导轨座组件- X***	Drive guide rail base - X***		10	4010100000	皮带压板 X 向	Belt pressing plate - X direction	
1.1	401001** **01	X 驱动座	X drive base		11	80031851- 4000	光轴 18-4000	Optical axis 18- 4000	
1.2	40100100 0002	驱动轴承座左	X drive bearing left		12	80031811BA	连轴套 Φ18 抱紧 式	Coupling shaft bushing Φ18 tight	
1.3	40100100 0003	驱动轴承座右	X drive bearing right						
1.4	40100100 0004	6904 轴承	6904 bearing						
1.5	40100100 0005	轴承内套	Inner bushing of bearing						
1.6	40100100 0006	驱动座盖	Drive base cover						
1.7	40100100 0007	张紧轮底座	Tensioning wheel base						
1.8	40100100 0008	张紧轮支架	Tensioning wheel support						
1.9	40100100 0009	张紧轮	Tensioning wheel						
1.10	40100100 0010	张紧轮轴\	Tensioning wheel shaft						
1.11	80031022	6000 轴承	6000 bearing						
1.12	40100100	卡簧	Circlip						

40101V1X 向驱动系统-伺服电机驱动部分表

40101V1. X Drive System –Servo Motor Drive Table

	0012								
2	401002** **	直线导轨组件	Linear guide rail assembly						
3	80025185 BA	驱动皮带 HTD5M- 50	Drive belt HTD5M-50						
4	40100401 **	步进电机	Step motor						
5	01110802	步进电机座-X110	Step motor base -X110						
6	40100600 00	主动带轮-HTD5M- 20 齿-50 宽	Driving pulley- HTD5M – 20 gear – 50 width						
7	80351101	限位开关	Limit switch						
8	401008** **	限位开关安装板组 件	Limit switch mounting plate assembly						
8.1	40100801 00	固定螺钉	Fastening screw						
8.2	40100802 00	限位开关支架	Limit switch bracket						
8.3	40100803 00	固定块	Fixed block						
8.4	40100804 00	调节卡槽	Adjusting slot						

40101V1X 向驱动系统-伺服电机驱动部分表
40101V1. X Drive System –Servo Motor Drive Table

9	40100900	触动支架	Touch support						
---	----------	------	---------------	--	--	--	--	--	--

40102V1 驱动系统-伺服电机驱动箱部分图
40102V1. Drive system - Servo Motor Drive Box Diagram

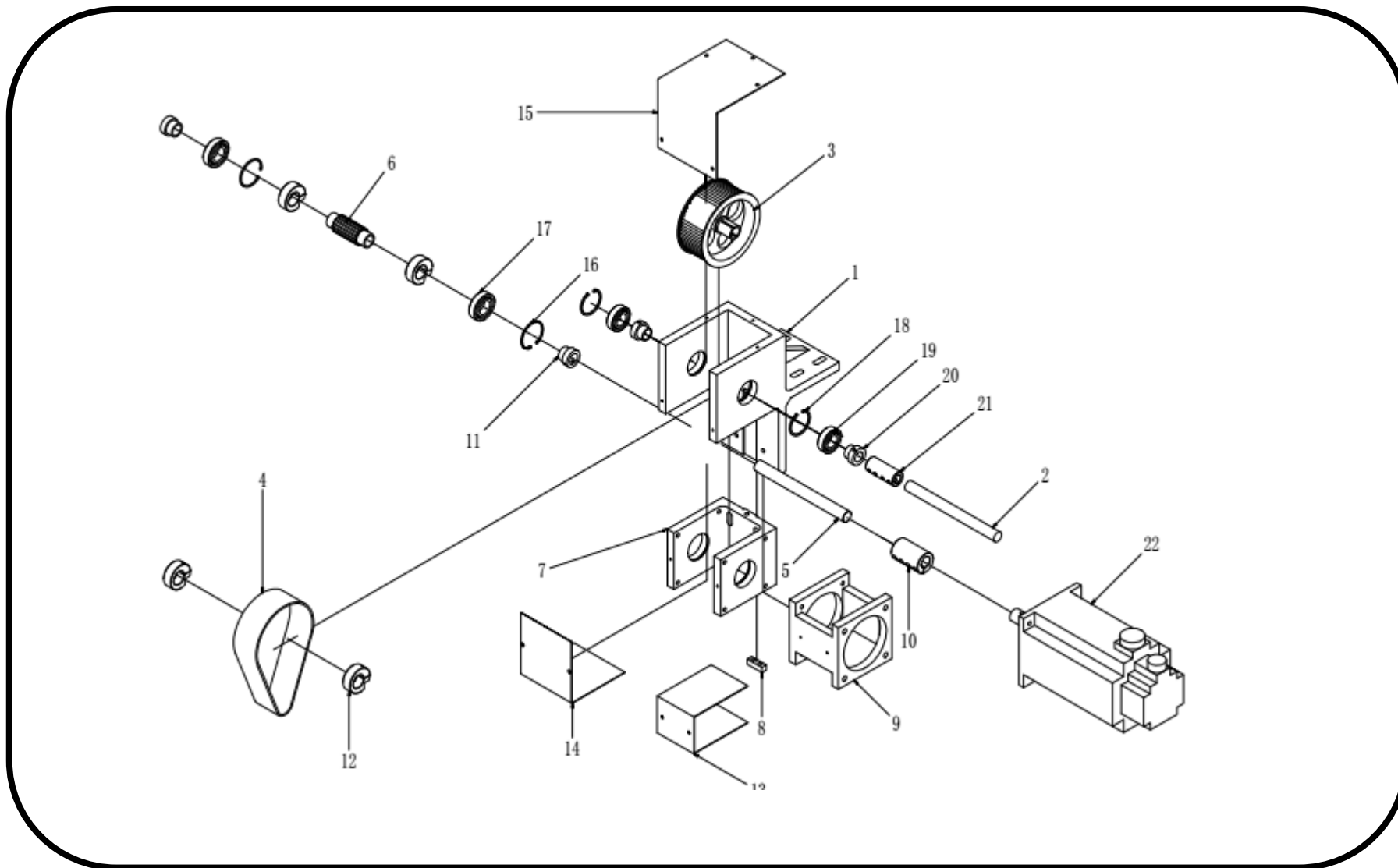

40102V1 驱动系统-伺服电机驱动箱部分表

40102V1. Drive system –Servo Motor Drive Box Table

指引号 Ref. No.	物料编码 Part No.	名称 Part Name		备注 Remark	指引号 Ref. No.	物料编码 Part No.	名称 Part Name	备注 Remark
1	4010050201	伺服驱动箱体	Servo drive box body					
2	1010050202	驱动大同步带轮轴 Φ18	Drive large synchronization pulley shaft Φ18					
3	4010050203	驱动大同步带轮	Drive large synchronization pulley shaft					
4	80025511	橡胶同步带 S5M-530-50	Rubber synchronization belt S5M-530-50					
5	4010050205	伺服电机带轮轴 XY	Servo motor pulley shaft XY					
6	4010050206	伺服电机带轮 XY	Servo motor pulley XY					
7	4010050207	电机带轮箱体-伺服驱动	Motor pulley body – servo drive					
8	4010050208	皮带张力调节块	Belt tension adjusting block					
9	4010050209	伺服电机座	Servo motor base					
10	4010050210	轴接套-19-抱轴式	Coupling bushing – 19 – bearing lock					
11	80031903	轴承套 Φ19-25	Bearing housingΦ19-25					
12	4010050212	同步带轮抱紧圈	Synchronization pulley tight ring					
13	4010050213	伺服电机座罩盖	Servo motor base cover					
14	4010050214	伺服带轮箱罩盖	Servo pulley cover					

40110V1Y 向驱动系统-步进电机驱动部分图

40110V1.Y Drive system - Step Motor Drive Diagram

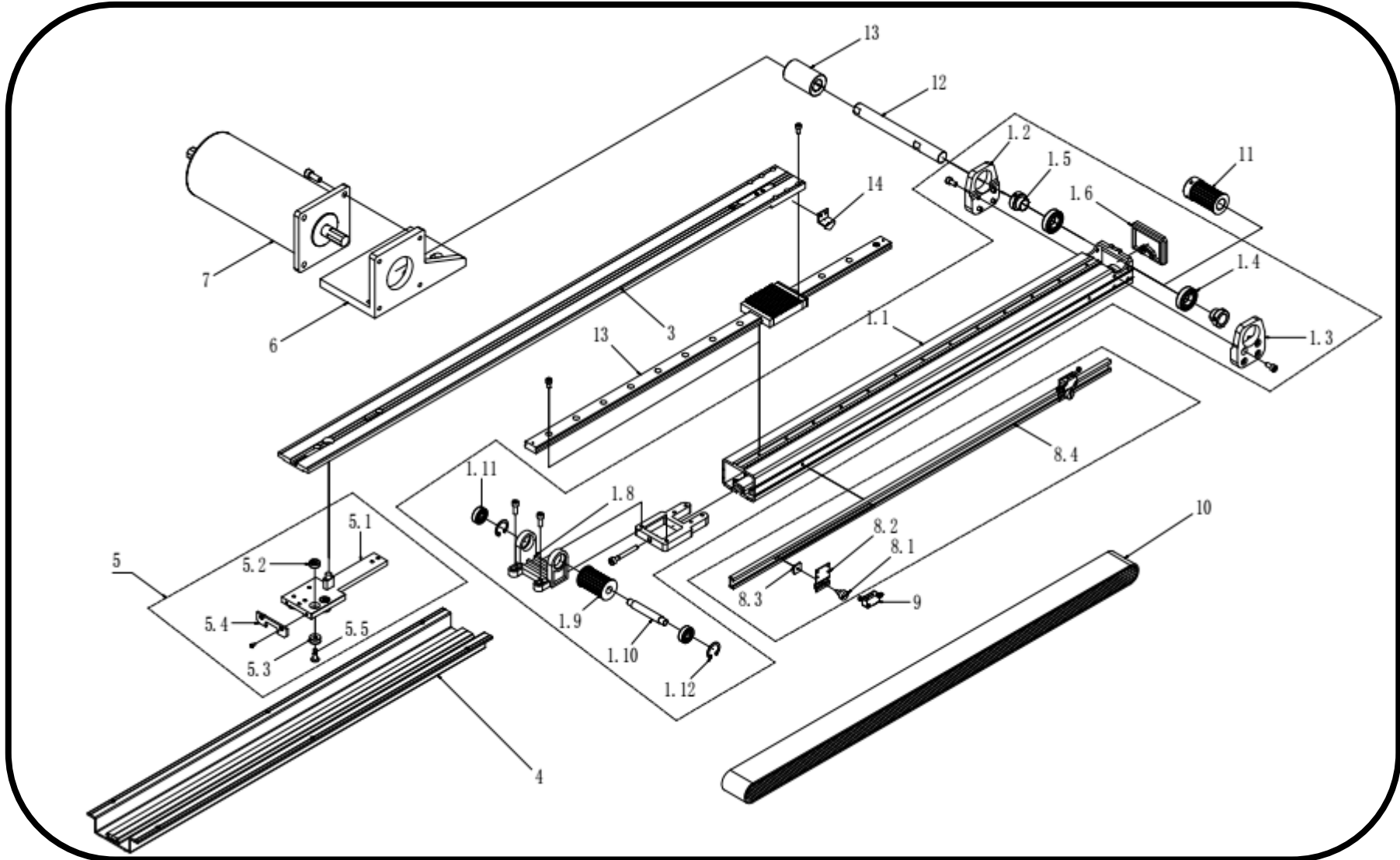

40110V1Y 向驱动系统-步进电机驱动部分表

40110V1.Y Drive System –Step Motor Drive Table

指引号 Ref. No.	物料编码 Part No.	名称 Part Name		备注 Remark	指引号 Ref. No.	物料编码 Part No.	名称 Part Name		备注 Remark
1	401101****	驱动座组件— Y***	Drive base assemb ly - Y***		8.2	4010080200	限位开关支架	Limit switch bracket	
1.1	401101****01	Y 驱动座	Y drive base		8.3	4010080300	固定块	Fixed block	
1.2	401001000002	驱动轴承座左	Drive bearing base left		8.4	4010080400	调节卡槽	Adjust slot	
1.3	401001000003	驱动轴承座右	Drive bearing base right		9	80351101	触动开关	Tact switch	
1.4	401001000004	6904 轴承	6904 Bearin g		10	80025185BA	同步带-PU 加绿 布-5M-50	Synchronizatio n belt – PU plus green cloth – 5M - 50	
1.5	401001000005	轴承内套	Inner bushin g of bearing		11	4010060000	主动带轮- HTD5M-20 齿-50 宽	Driving pulley -HTD5M-20 gear – 50 width	
1.6	401001000006	驱动座盖	Drive base cover		12	80031851	Φ18 轴	Φ18 shaft	
1.7	401001000007	张紧轮底座	Tensio ning wheel base		13	80031811	连轴套 Φ18	Coupling sleeve Φ18	

40110V1Y 向驱动系统-步进电机驱动部分表

40110V1.Y Drive System –Step Motor Drive Table

1.8	401001000008	张紧轮支架	Tensioning wheel support		14	4010090000	限位开关触动支架	Limit switch touch support	
1.9	401001000009	张紧轮	Tensioning wheel						
1.10	401001000010	张紧轮轴	Tensioning wheel bearing						
1.11	80031022	6000 轴承	6000 Bearing						
1.12	401001000012	卡簧	Circlip						
2	401002****	直线导轨组件	Linear guide rail assembly						
3	401103****	正副导轨连接板—Y****	Connecting plate of main guide rail and auxiliary guide rail - Y****						

40110V1Y 向驱动系统-步进电机驱动部分表

40110V1.Y Drive System –Step Motor Drive Table

4	401104****	副导轨—Y****	Auxiliary guide rail - Y****						
5	4011050000	副导轨小车组件	Auxiliary guide rail trolley assembly						
5.1	4011050100	小车板	Trolley plate						
5.2	4011050200	间隙调节圈	Gap adjusting ring						
5.3	4011050300	U形轴承	U-shape bearing						
5.4	4011050400	挡胶	Blocking glue						
5.5	4011050500	柱头	Chapiter						
6	01110801	Y 步进电机座	Y step motor base						
7	40100401**	步进电机	Step motor						
8	401008****	限位开关安装板组件	Limit switch mounting plate						

40110V1Y 向驱动系统-步进电机驱动部分表
40110V1.Y Drive System –Step Motor Drive Table

			assembly						
8.1	4010080100	固定螺钉	Fastening screw						

40111V1Y 向驱动系统-伺服电机驱动部分图

40111V1.Y Drive System –Servo Motor Drive Diagram

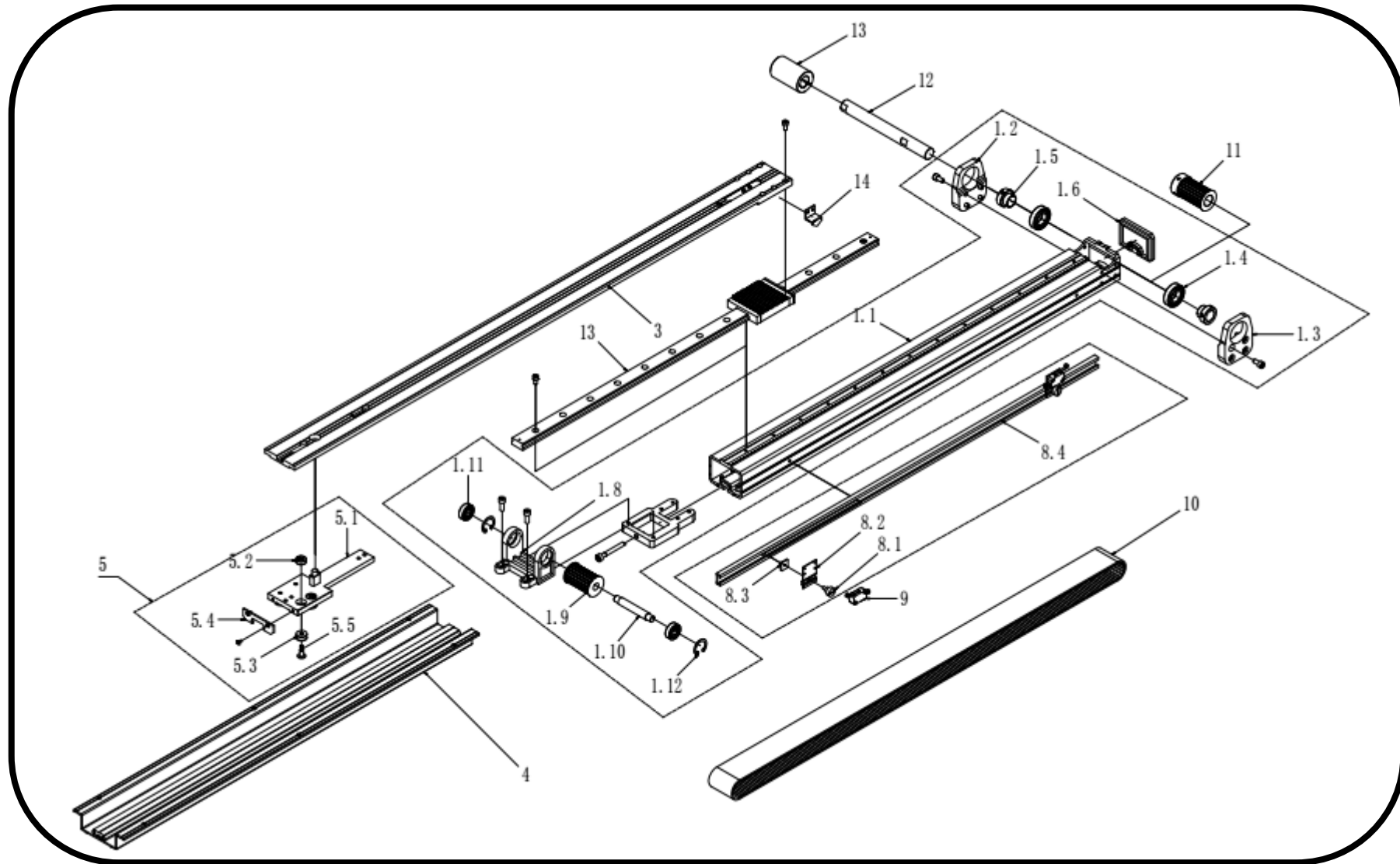

40111V1Y 向驱动系统-伺服电机驱动部分表
40111V1.Y Drive System –Servo Motor Drive Table

指引号 Ref. No.	物料编码 Part No.	名称 Part Name		备注 Remark	指引号 Ref. No.	物料编码 Part No.	名称 Part Name		备注 Remark
1	401101****	驱动座组件— Y***	Drive base assemb ly - Y***		8. 2	401008020 0	限位开关支架	Limit switch bracket	
1. 1	401101****01	Y 驱动座	Y drive base		8. 3	401008030 0	固定块	Fixed block	
1. 2	401001000002	驱动轴承座左	Drive bearing base left		8. 4	401008040 0	调节卡槽	Adjust slot	
1. 3	401001000003	驱动轴承座右	Drive bearing base right		9	80351101	触动开关	Tact switch	
1. 4	401001000004	6904 轴承	6904 Bearing		10	80025185B A	同步带-PU 加绿 布-5M-50	Synchro nization belt – PU plus green cloth – 5M - 50	
1. 5	401001000005	轴承内套	Inner bushing of bearing		11	401006000 0	主动带轮- HTD5M-20 齿- 50 宽	Driving pulley - HTD5M -20 gear – 50 width	
1. 6	401001000006	驱动座盖	Drive base		12	80031851	Φ18 轴	Φ18 shaft	

40111V1Y 向驱动系统-伺服电机驱动部分表
40111V1.Y Drive System –Servo Motor Drive Table

			cover						
1.7	401001000007	张紧轮底座	Tensioning wheel base		13	80031811	连轴套 Φ18	Coupling sleeve Φ18	
1.8	401001000008	张紧轮支架	Tensioning wheel support		14	4010090000	限位开关触动支架	Limit switch touch support	
1.9	401001000009	张紧轮	Tensioning wheel						
1.10	401001000010	张紧轮轴	Tensioning wheel bearing						
1.11	80031022	6000 轴承	6000 Bearing						
1.12	401001000012	卡簧	Circlip						
2	401002****	直线导轨组件	Linear guide rail assembly						
3	401103****	正副导轨连接板—Y****	Connecting plate of main guide rail and auxiliary						

40111V1Y 向驱动系统-伺服电机驱动部分表
40111V1.Y Drive System –Servo Motor Drive Table

			y guide rail - Y****						
4	401104****	副导轨—Y****	Auxiliary guide rail - Y****						
5	4011050000	副导轨小车组件	Auxiliary guide rail trolley assembly						
5.1	4011050100	小车板	Trolley plate						
5.2	4011050200	间隙调节圈	Gap adjusting ring						
5.3	4011050300	U形轴承	U-form bearing						
5.4	4011050400	挡胶	Blocking glue						
5.5	4011050500	柱头	Chapiter						
6	01110801	Y 步进电机座	Y step motor base						
7	40100401**	步进电机	Step motor						
8	401008****	限位开关安装	Limit						

40111V1Y 向驱动系统-伺服电机驱动部分表
40111V1.Y Drive System –Servo Motor Drive Table

		板组件	switch mounti ng plate assemb ly						
8.1	4010080100	固定螺钉	Fasteni ng screw						

40120V1 绣框部分图

40120V1.Frame Diagram

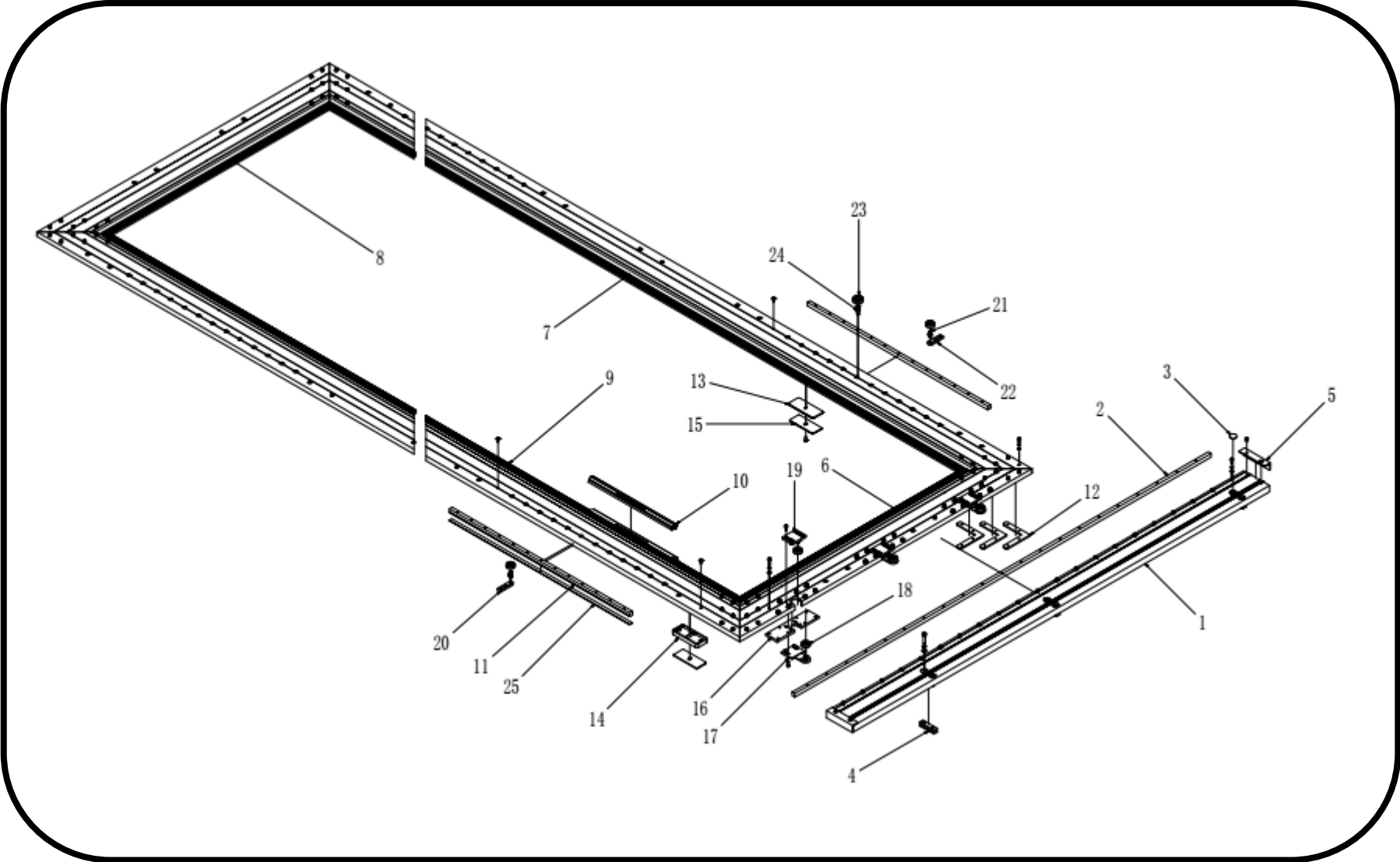

40120V1 绣框部分图
40120V1.Frame Diagram

指引号 Ref. No.	物料编码 Part No.	名称 Part Name		备注 Remark	指引号 Ref. No.	物料编码 Part No.	名称 Part Name	备注 Remark
1	401201****	绣框加强档—Y****	Tabouret reinforce barrier - Y***					
2	4012020***	加强档导轨—Y***	Reinforce barrier guide rail - Y***					
3	4012030000	孔塞 Φ19	Spout plug Φ19					
4	4012040000	工字型垫块	I-shaped pad					
5	4012050000	加强档挡片	Reinforce barrier					
6	401206****	绣框右挡	Tabouret right barrier					
7	401207****	绣框后档	Tabouret rear barrier					
8	401208****	绣框左档	Tabouret left barrier					
9	401209****	绣框前档	Tabouret front barrier					
10	401210****	步夹	Step clamp					
11	401211****	绣框前后导轨条— X***	Tabouret front & rear guide rail strip - X***					
12	02513010	直角架-CT 平绣	Right angle rack - CT plain embroidery					
13	01501012	羊毛毡座	Wool felt base					

40120V1 绣框部分图
40120V1.Frame Diagram

14	01501011	厚羊毛毡座	Thick wool felt base					
15	71125121	毛毡	Felt					
16	4012160000	轴承座底板-608	Bearing base plate -608					
17	4012170000	轴承座-608	Bearing base - 608					
18	80030823	深沟球轴承 22-8-7	Deep groove roller bearing 22-8-7					
19	4012190000	轴承活动板-608	Bearing movable plate - 608					
20	4012200000	前顶轮滑块组件	Front pulley slider assembly					
21	4012210000	后顶轮柱头	Rear pulley chapter					
22	4012220000	后顶轮滑块	Rear pulley slider					
23	80031022	深沟球轴承-6000	Deep groove roller bearing - 6000					
24	4012240000	轴承柱头-6000	Bearing chapter - 6000					
25	4012250000	前后导轨棉条	Front & rear guide rail cotton sliver					

40121V1 绣框选配部分图
40121V1.Frame Optional Parts Diagram

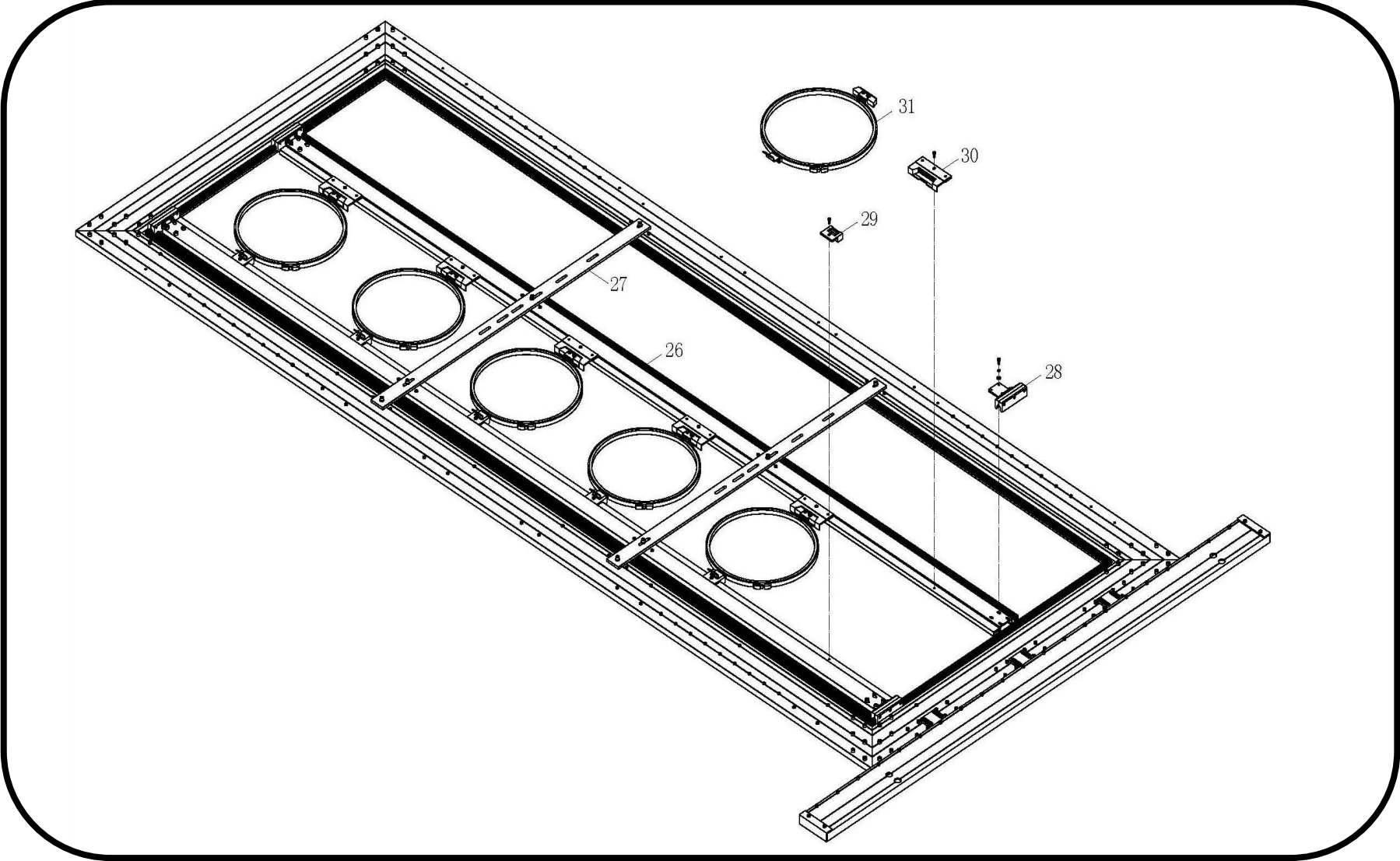

40130V1 线盘线架部分图
40130V1.Thread Coil and Stand Diagram

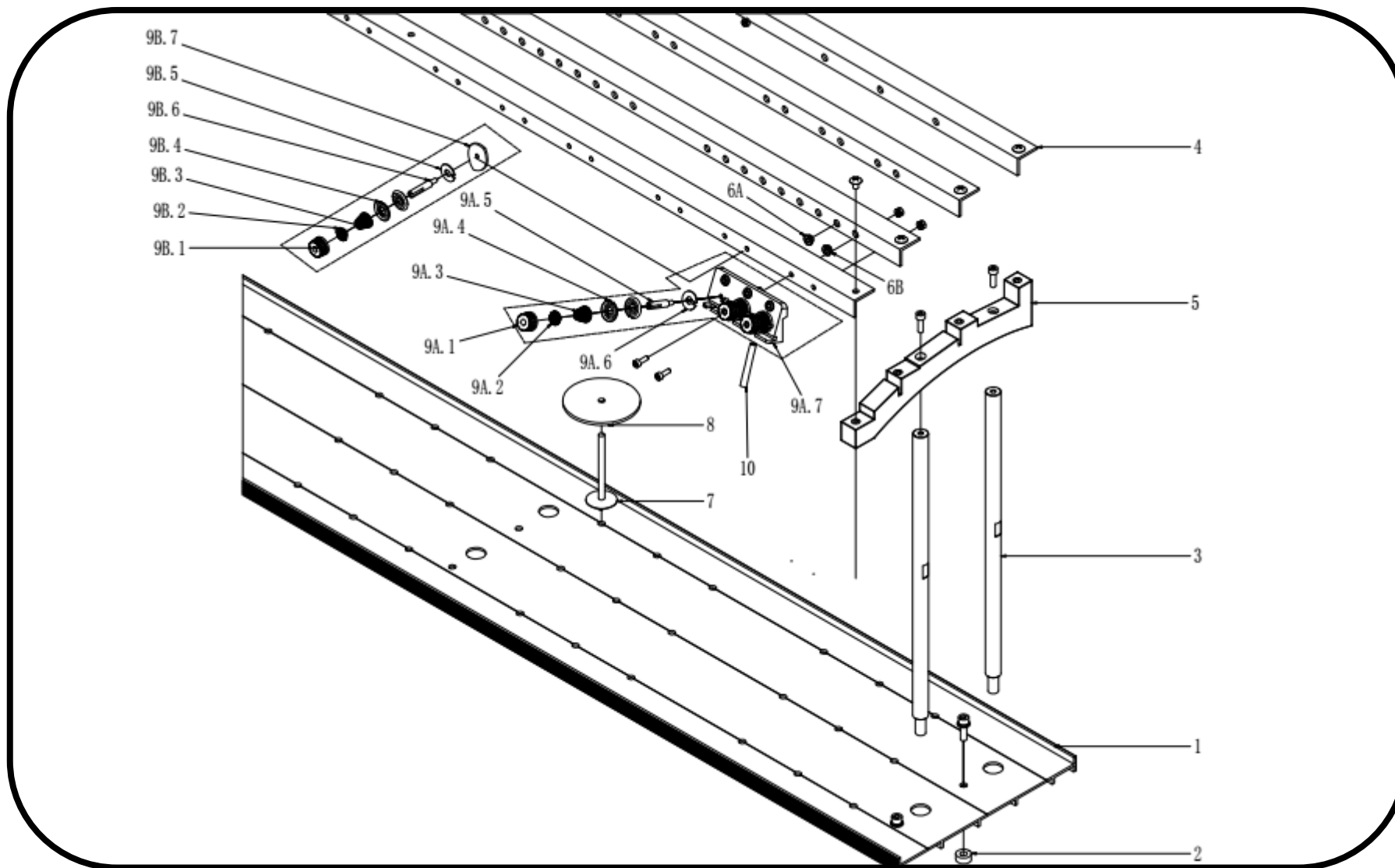

40130V1 线盘线架部分表
40130V1.Thread Coil and Stand Table

指引号 Ref. No.	物料编码 Part No.	名称 Part Name		备注 Remark	指引号 Ref. No.	物料编码 Part No.	名称 Part Name	备注 Remark
1	401301****	线盘	Thread coil					
2	4013020000	线盘垫圈	Thread coil gasket					
3	01903101	线架立柱	Thread stand pillar					
4	401304****	线架角铝	Thread stand aluminum angle					
5	4013050000	线架斜梁	Thread stand cant beam					
6A	80211005	过线瓷套（白）	Thread cross porcelain bushing (white)					
6B	80211006	过线瓷套（红）	Thread cross porcelain bushing (red)					
7	80211007	线柱	Thread pillar					
8	80211008	海绵垫	Sponge pad					
9A	80210520	普通旋钮组件	Common knob assembly					
9A. 1	4013090101	旋钮	Knob					
9A. 2	4013090102	防松胶圈	Lock rubber ring					
9A. 3	4013090103	压紧弹簧	Retainer spring					

40130V1 线盘线架部分表
40130V1.Thread Coil and Stand Table

9A. 4	4013090104	线夹片	Thread clip					
9A. 5	4013090105	防震棉垫	Shakeproof cotton pad					
9A. 6	4013090106	旋钮柱	Knob pillar					
9A. 7	4013090107	过线片	Thread cross sheet					
9B	72015161	三位一体式旋钮组件	Trinity knob assembly					
9B. 1	4013090101	旋钮	Knob					
9B. 2	4013090102	防松胶圈	Lock rubber ring					
9B. 3	4013090103	压紧弹簧	Retainer spring					
9B. 4	4013090104	线夹片	Thread clip					
9B. 5	4013090105	防震棉垫	Shakeproof cotton pad					
9B. 6	4013090106	旋钮柱	Knob pillar					
9B. 7	4013090107	三位旋钮座	Trinity knob base					
10	401310****	过线管	Thread cross pipe					

40140V1 电控系统-轮+簧夹线器断检部分图

40140V1.Electronic Control System –Wheel + Spring Thread tension base Fault Detection Diagram

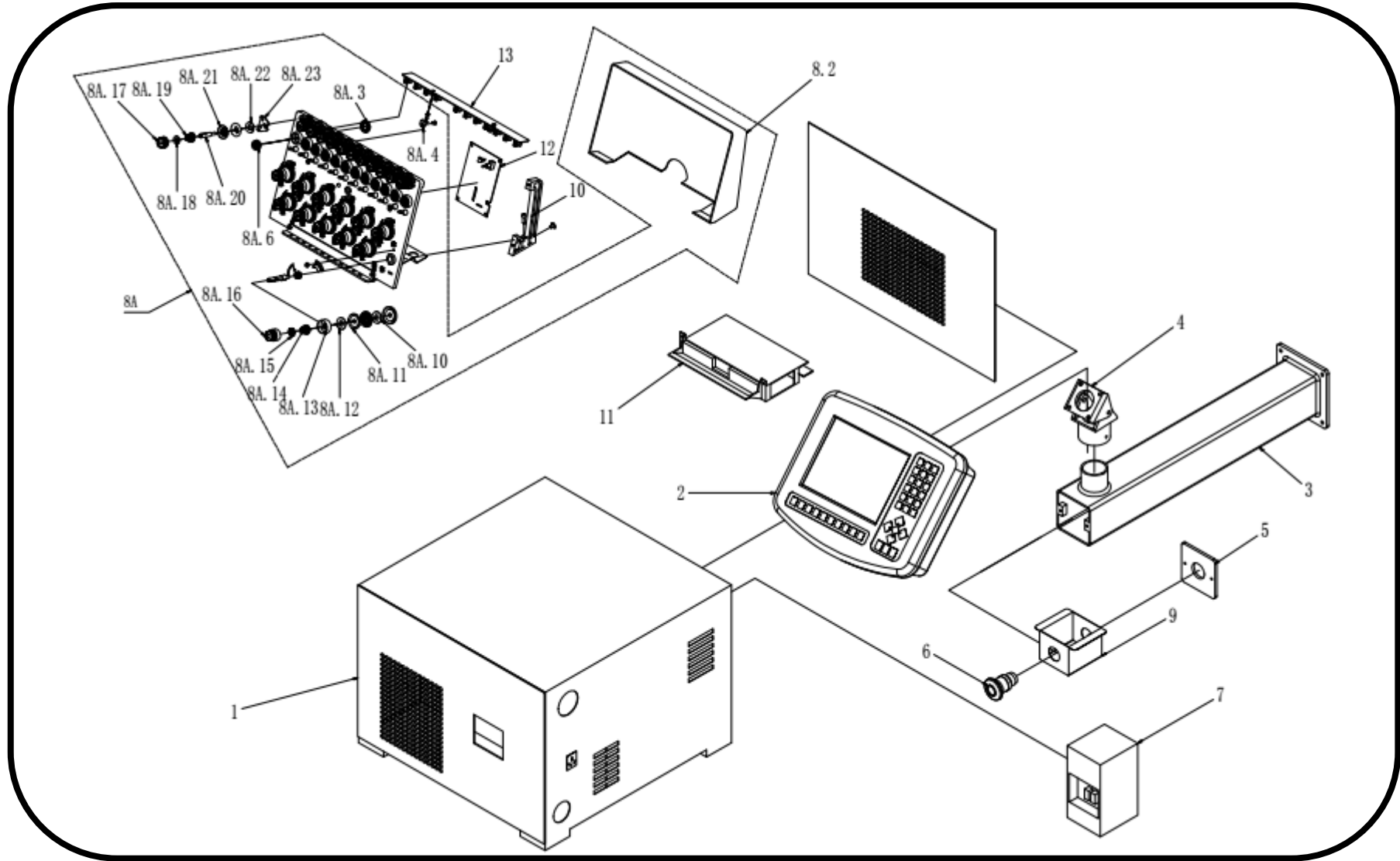

40140V1 电控系统总表一
40140V1. Electronic Control System General Table 1

指引号 Ref. No.	物料编码 Part No.	名称 Part Name		备注 Remark	指引号 Ref. No.	物料编码 Part No.	名称 Part Name		备注 Remark
1	401401****	一体式主控箱	Integrated master control		8A. 19	401408010019	压簧	Pressure spring	
2	401402****	电脑操作头	Computer operation head		8A. 20	401408010020	小旋钮柱	Small rotary pillar	
3	401403****	操作头支撑	Operation head support		8A. 21	401408010021	夹线片	Thread clamping sheet	
4	01750141	万向接头	Universal joint		8A. 22	401408010022	防震棉垫	Shakeproof cotton pad	
5	4014050000	急停开关安装板	Emergency switch mounting plate		8A. 23	401408010023	过线片	Thread cross sheet	
6	80233111	急停开关	Emergency switch		8B	401408B***	(纯轮) 夹线座组件	(Pure pulley) Thread clamping base assembly	
7	401407****	主电源空开	Main power air switch		8B. 1	40140802**01	夹线座板	Thread clamping base plate	
8A	401408A***	(轮+簧) 夹线座组件	(Wheel + spring) Thread clamping base assembly		8B. 2	401408020002	斩光理论	Chopping theory	

40140V1 电控系统总表一
40140V1. Electronic Control System General Table 1

8A. 1	40140801** 01	夹线座板	Thread clamping plate		8B. 3	401408020003	斩光绕线轮	Chopping winding pulley	
8A. 2	40140801** 02	夹线座后盖	Thread clamping rear cover		8B. 4	401408020004	旋钮立柱	Knob pillar	
8A. 3	4014080100 03	斩光轮	Chopping wheel		8B. 5	401408020005	防震棉垫	Shakeproof cotton pad	
8A. 4	4014080100 04	光耦板支架	Optocoupl er plate support		8B. 6	401408020006	夹线片	Thread clamping sheet	
8A. 5	4014080100 05	过线支架	Thread cross support		8B. 7	401408020007	压簧	Pressure spring	
8A. 6	4014080100 06	斩光绕线轮	Chopping winding pulley		8B. 8	401408020008	防松胶圈	Lock rubber ring	
8A. 7	4014080100 07	铜片	Copper sheet		8B. 9	401408020009	旋钮	Knob	
8A. 8	4014080100 08	挑线簧	Take-up spring		8B. 10	401408020010	夹线片螺钉	Thread clamping sheet screw	
8A. 9	4014080100 09	大旋钮柱	Large knob pillar		8B. 11	401408020011	压簧	Pressure spring	
8A. 10	4014080100 10	挡片	Barrier sheet		8B. 12	401408020012	方形夹线片	Square Thread clamping sheet	
8A. 11	4014080100 11	防震棉垫	Shakeproo f cotton pad		8B. 13	40140802**13	夹线条	Thread clamping stripe	

40140V1 电控系统总表一
40140V1. Electronic Control System General Table 1

8A. 12	4014080100 12	挑线绕线轮	Take-up & winding pulley		8B. 14	40140802**14	羊毛毡条	Wool felt stripe	
8A. 13	4014080100 13	压簧杯座	Pressure spring cup base		8B. 15	40140802**15	光耦板安装条 A	Optocoupler plate mounting stripe A	
8A. 14	4014080100 14	压簧	Pressure spring		8B. 16	40140802**16	光耦板安装条 B	Optocoupler plate mounting stripe B	
8A. 15	4014080100 15	防松胶圈	Lock rubber ring		8B. 17	40140802**17	夹线座后盖	Thread clamping base rear cover	
8A. 16	4014080100 16	大旋钮	Large knob		9	4014090000	急停开关盒	Emergency switch box	
8A. 17	4014080100 17	小旋钮	Small knob		10	401410****	夹线座支架	Thread clamping base support	
8A. 18	4014080100 18	防松胶圈	Lock rubber ring		11	401411****	线槽盒	Trunking box	

440141V1 电控系统-纯轮夹线器断检部分图

40141V1. Electronic control system – wheel thread tension base fault detection diagram

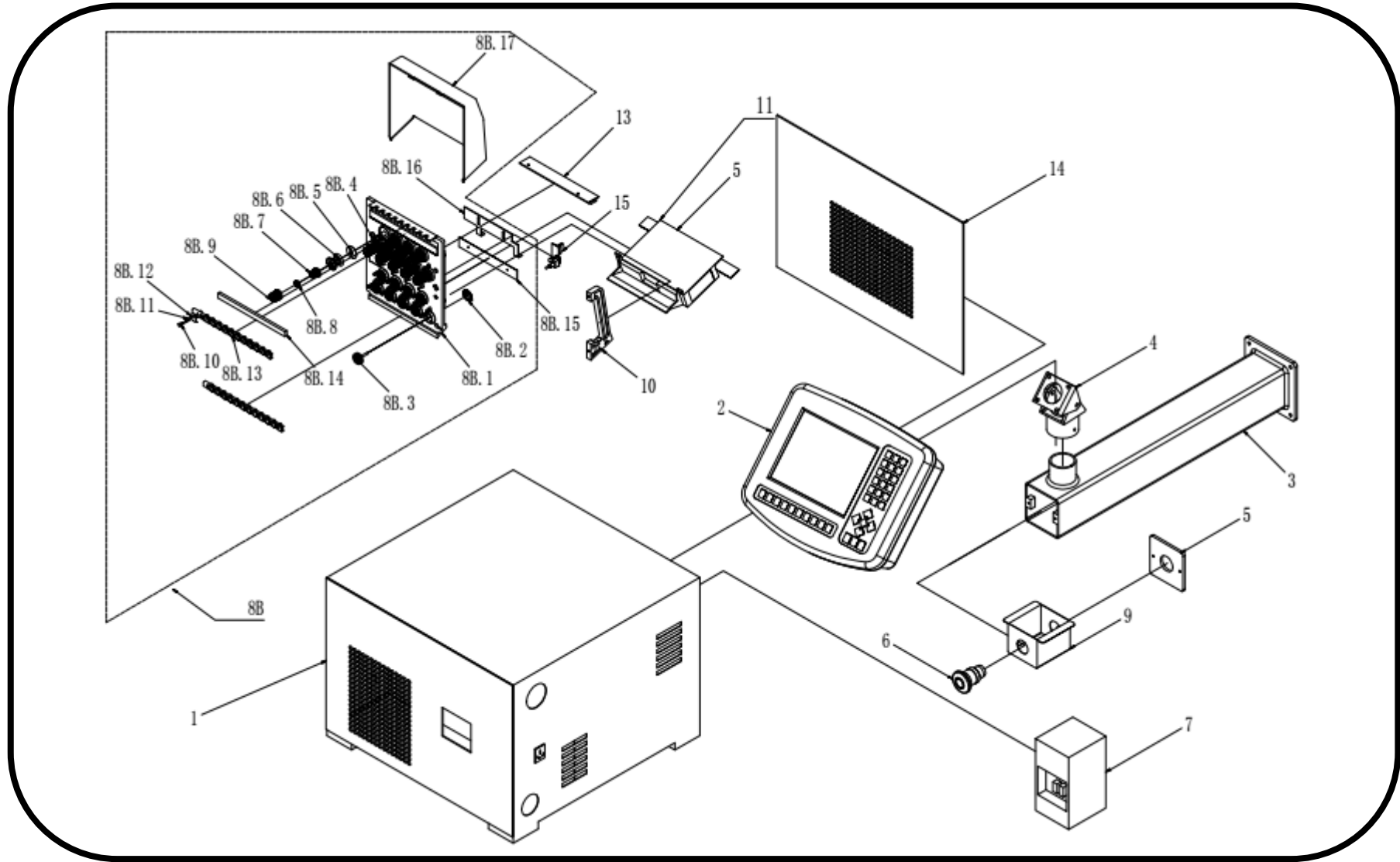

40141V1 电控系统总表一
40141V1. Electronic Control System General Table 1

指引号 Ref. No.	物料编 码 Part No.	名称 Part Name		备注 Remark	指引号 Ref. No.	物料编码 Part No.	名称 Part Name		备注 Remark
1	401401 ****	一体式主控箱	Integrated master control		8A. 19	401408010019	压簧	Pressure spring	
2	401402 ****	电脑操作头	Computer operation head		8A. 20	401408010020	小旋钮柱	Small rotary pillar	
3	401403 ****	操作头支撑	Operation head support		8A. 21	401408010021	夹线片	Thread clamping sheet	
4	017501 41	万向接头	Universal joint		8A. 22	401408010022	防震棉垫	Shakeproof cotton pad	
5	401405 0000	急停开关安装板	Emergency switch mounting plate		8A. 23	401408010023	过线片	Thread cross sheet	
6	802331 11	急停开关	Emergency switch		8B	401408B***	(纯轮) 夹线座组 件	(Pure pulley) Thread clamping base assembly	
7	401407 ****	主电源空开	Main power air switch		8B. 1	40140802**01	夹线座板	Thread clamping base plate	
8A	401408 A***	(轮+簧) 夹线座 组件	(wheel + spring) Thread clamping base assembly		8B. 2	401408020002	斩光理论	Chopping theory	

40141V1 电控系统总表一
40141V1. Electronic Control System General Table 1

8A. 1	401408 01**01	夹线座板	Thread clamping plate		8B. 3	401408020003	斩光绕线轮	Chopping winding pulley	
8A. 2	401408 01**02	夹线座后盖	Thread clamping rear cover		8B. 4	401408020004	旋钮立柱	Rotary knob pillar	
8A. 3	401408 010003	斩光轮	Chopping wheel		8B. 5	401408020005	防震棉垫	Shakeproof cotton pad	
8A. 4	401408 010004	光耦板支架	Optocoupler plate support		8B. 6	401408020006	夹线片	Thread clamping sheet	
8A. 5	401408 010005	过线支架	Thread cross support		8B. 7	401408020007	压簧	Pressure spring	
8A. 6	401408 010006	斩光绕线轮	Chopping winding pulley		8B. 8	401408020008	防松胶圈	Lock rubber ring	
8A. 7	401408 010007	铜片	Copper sheet		8B. 9	401408020009	旋钮	Knob	
8A. 8	401408 010008	挑线簧	Take-up spring		8B. 10	401408020010	夹线片螺钉	Thread clamping sheet screw	
8A. 9	401408 010009	大旋钮柱	Large knob pillar		8B. 11	401408020011	压簧	Pressure spring	
8A. 10	401408 010010	挡片	Barrier sheet		8B. 12	401408020012	方形夹线片	Square Thread clamping sheet	
8A. 11	401408 010011	防震棉垫	Shakeproof cotton pad		8B. 13	40140802**13	夹线条	Thread clamping stripe	

40141V1 电控系统总表一
40141V1. Electronic Control System General Table 1

8A. 12	401408 010012	挑线绕线轮	Take-up & winding pulley		8B. 14	40140802**14	羊毛毡条	Wool felt stripe	
8A. 13	401408 010013	压簧杯座	Pressure spring cup base		8B. 15	40140802**15	光耦板安装条 A	Optocoupler plate mounting stripe A	
8A. 14	401408 010014	压簧	Pressure spring		8B. 16	40140802**16	光耦板安装条 B	Optocoupler plate mounting stripe B	
8A. 15	401408 010015	防松胶圈	Lock rubber ring		8B. 17	40140802**17	夹线座后盖	Thread clamping base rear cover	
8A. 16	401408 010016	大旋钮	Large knob		9	4014090000	急停开关盒	Emergency switch box	
8A. 17	401408 010017	小旋钮	Small knob		10	401410****	夹线座支架	Thread clamping base support	
8A. 18	401408 010018	防松胶圈	Lock rubber ring		11	401411****	线槽盒	Trunking box	

40150V1 面线夹持装置图
40150V1. Face Thread Holding Device Diagram

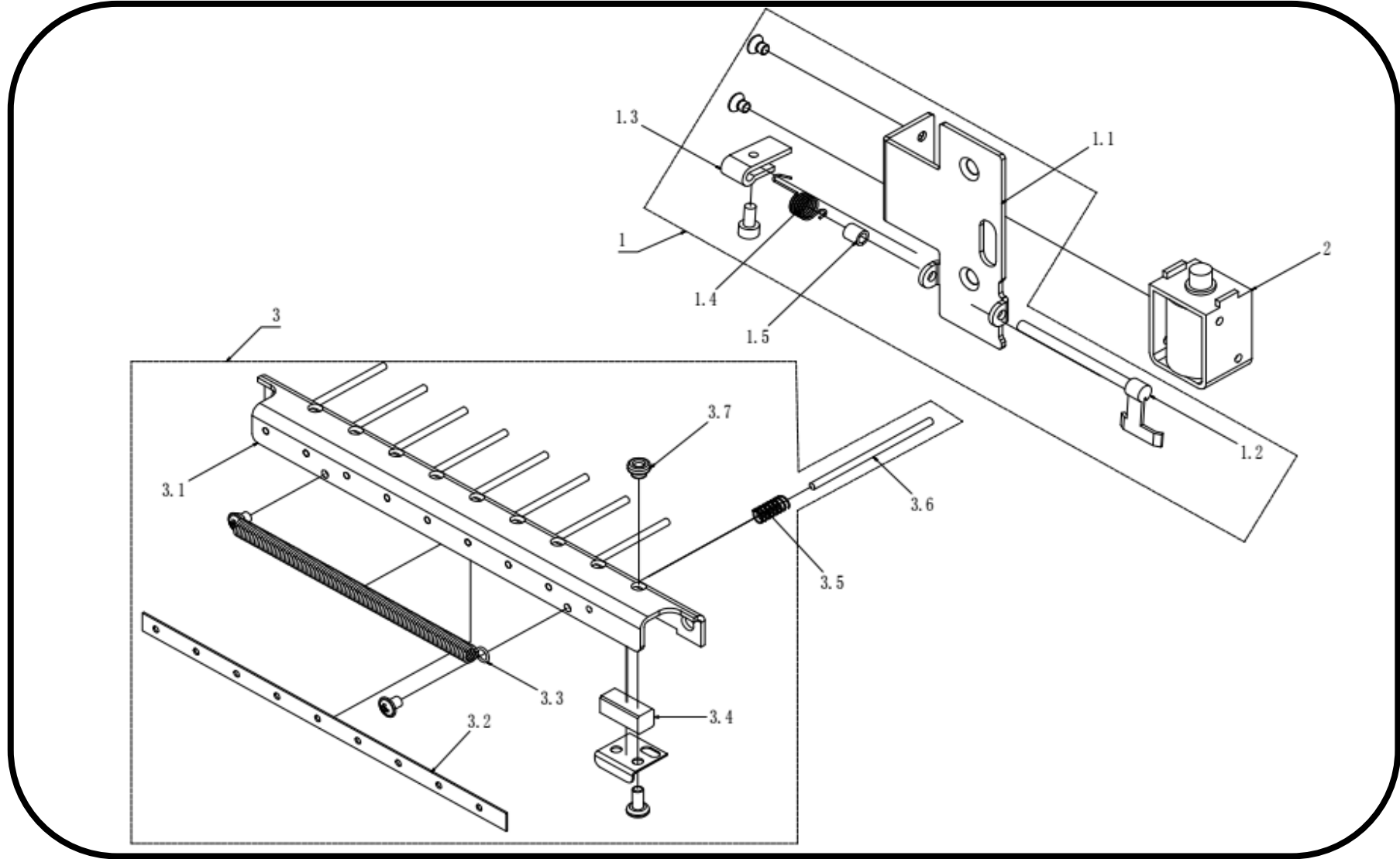

40150V1 面线夹持装置表
40150V1. Face Thread Holding Device Table

指引号 Ref. No.	物料编码 Part No.	名称 Part Name		备注 Remark	指引号 Ref. No.	物料编码 Part No.	名称 Part Name	备注 Remark
1	4015010000	电磁铁支架组件	Electroma gnetic support assembly					
1.1	4015010100	电磁铁安装支架	Electroma gnetic mounting support					
1.2	4015010200	拨动连杆	Toggle connectin g rod					
1.3	4015010300	触动夹片	Touch clamp					
1.4	4015010400	扭簧	Torsional spring					
1.5	4015010500	扭簧胶套	Torsional spring rubber sleeve					
2	4015020000	双向保持电磁铁	Bidirectio nal holding electroma gnet					
3	4015030000	夹线式下过线组 件	Clamping lower cross thread assembly					
3.1	4015030100	夹线支架	Thread					

