



MT-2T Series
PARTS
BOOK

Version:20171129

THINK BEYOND

INDEX

01.Lower Stand-MT-2T

1

02.Rotary Hook Arm-MT-2T

3

03.HeadColor Change-MT-2T

5

04.Needle Bar Case-MT-2T

7

05.Trim and Driving-MT-2T

9

06.Y-Axis Driving-MT-2T

11

07.X-Axis Driving-MT-2T

13

08.Thread Support & Stand-MT-2T

15

09.Thread Tension Base-MT-2T

17

10.Electrical Part-MT-2T

19

11.Frame-MT-2T

21

12.Cap Driver-MT-2T

23

13.Table-MT-2T

25

01.Lower Stand-MT-2T

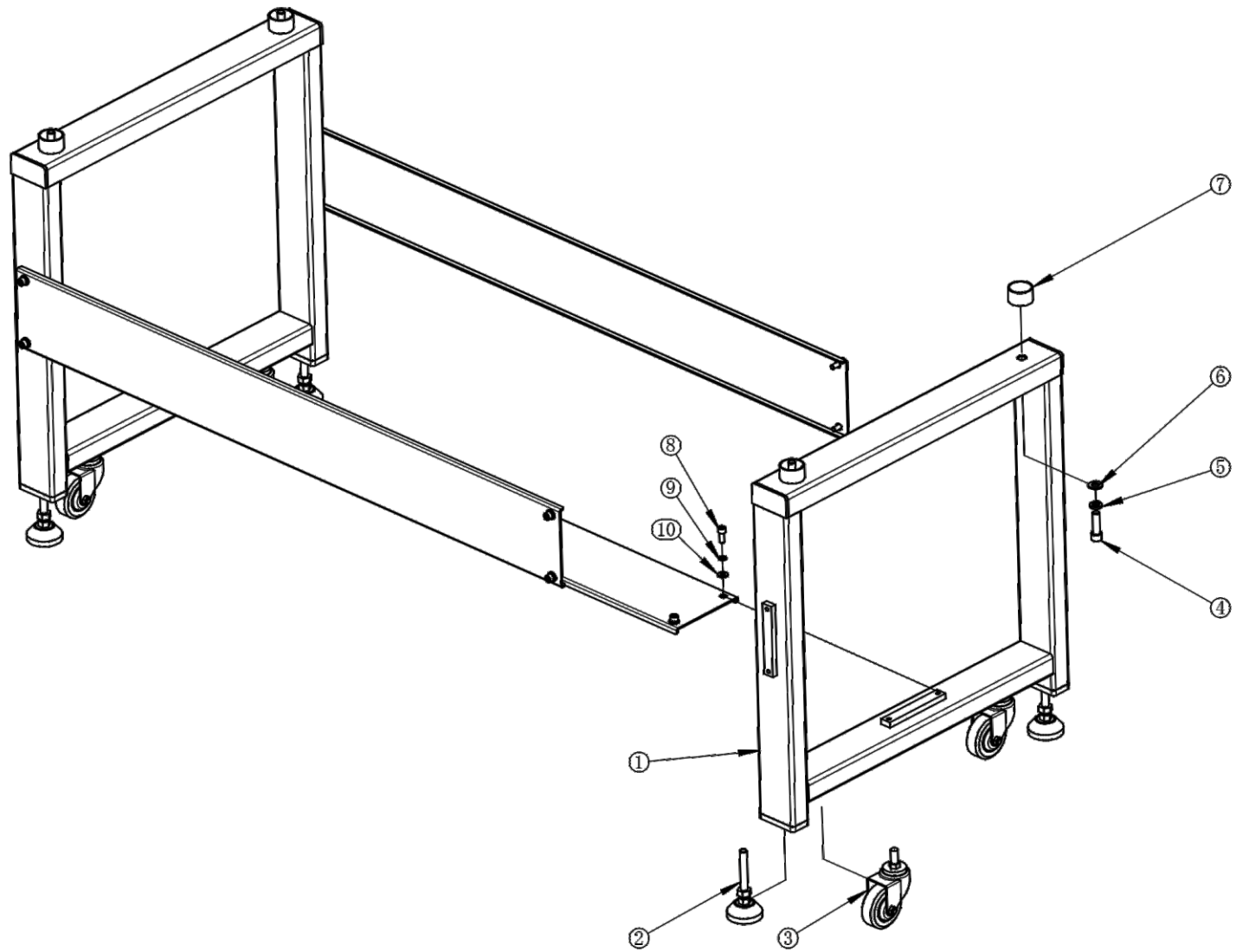

01.Lower Stand-MT-2T

No.	Serial No.	Part name	Remark
1	3011100222	Side rack-Lower rack-MT-2T	
2	80270831	Support Feet-Nylon-Φ50-M12*50	
3	80270501	Screw lever truckle-65M12	
4	80811240	M12x40 Hexagon socket head	
5	80901213	M12 spring cushion-black	

No.	Serial No.	Part name	Remark
6	80901202	M12 thick flat cushion- nickel-plated	
7	3011100121	Rubber podotheca-40	
8	80813820	M8x20 hexagon socket head	
9	80900818	M8 spring cushion-stainless steel	
10	80900801	M8 plain washer-nickel-plated(17*2)	

02.Rotary Hook Arm-MT-2T

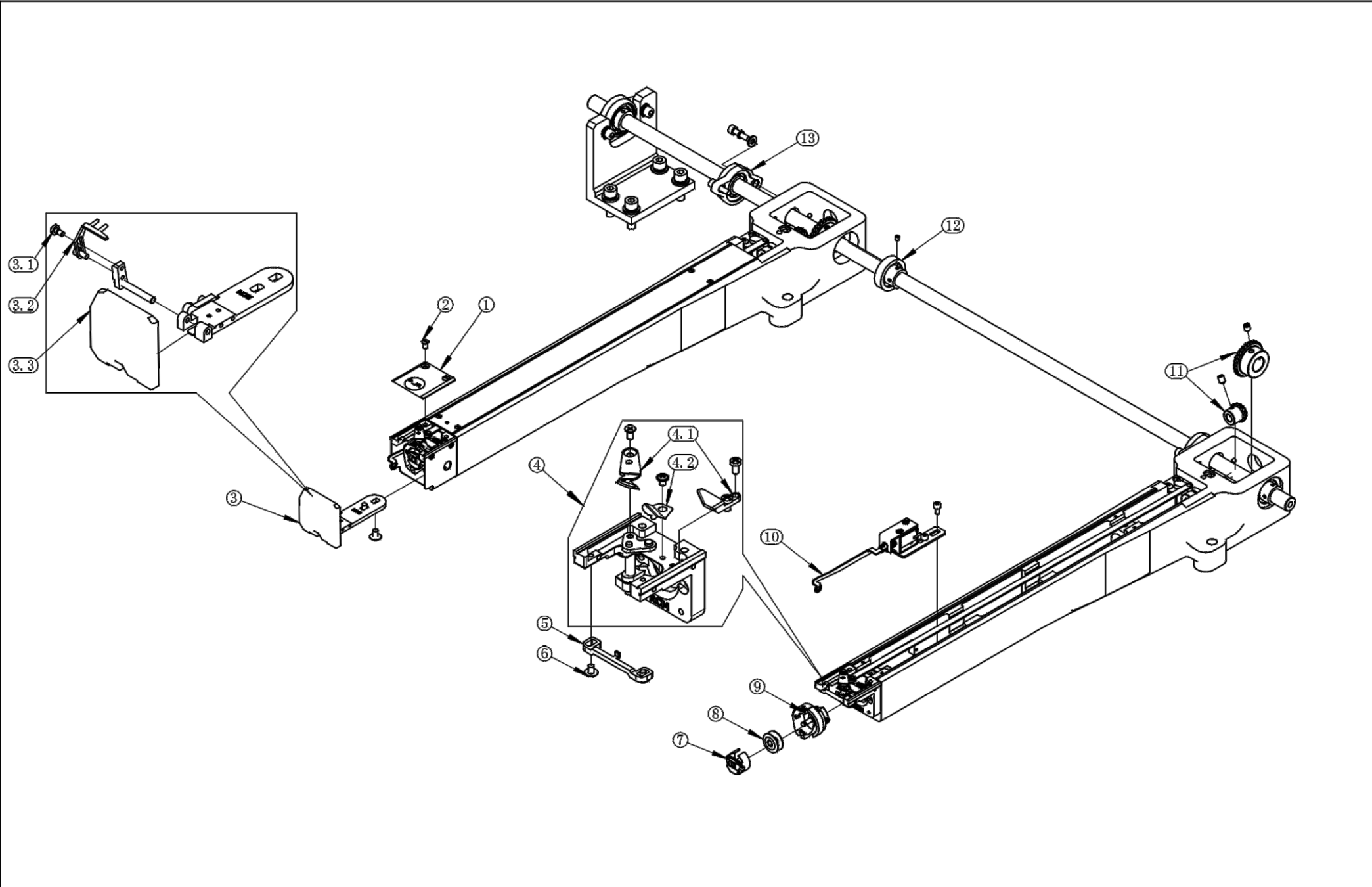

02.Rotary Hook Arm-MT-2T

No.	Serial No.	Part name	Remark
1	02101611VA	Needle Plate-SR-C-H	
2	80924131	Counter bore slotted screw 11/64 x 6	
3	02101661	Picker assembly-SR-C	
3.1	02010625	Picker rod screw-SY	
3.2	02010624	Picker-SY	
3.3	02101622	Fore cover -SR-C	
4	02101660	Needle plate base assembly-SR-C	
4.1	02101282	Trimming set	
4.2	02101233	fixed knife shrapnel	

No.	Serial No.	Part name	Remark
5	03021322	locating hook-rotary hook-RCM-short	
6	80746304	Screw-M3x4	
7	80620301	bobbin case	
8	80746304	bobbin	
9	80620291	koban rotary hook-KHS12-RVP	
10	02010665VA	Picker electromagnet assembly-small needle plate	
11	01030133	bevel gear set	
12	80031522	bearing-60/15-15x35x19	
13	80039011	bearing UFL002-D15	

03.HeadColor Change-MT-2T

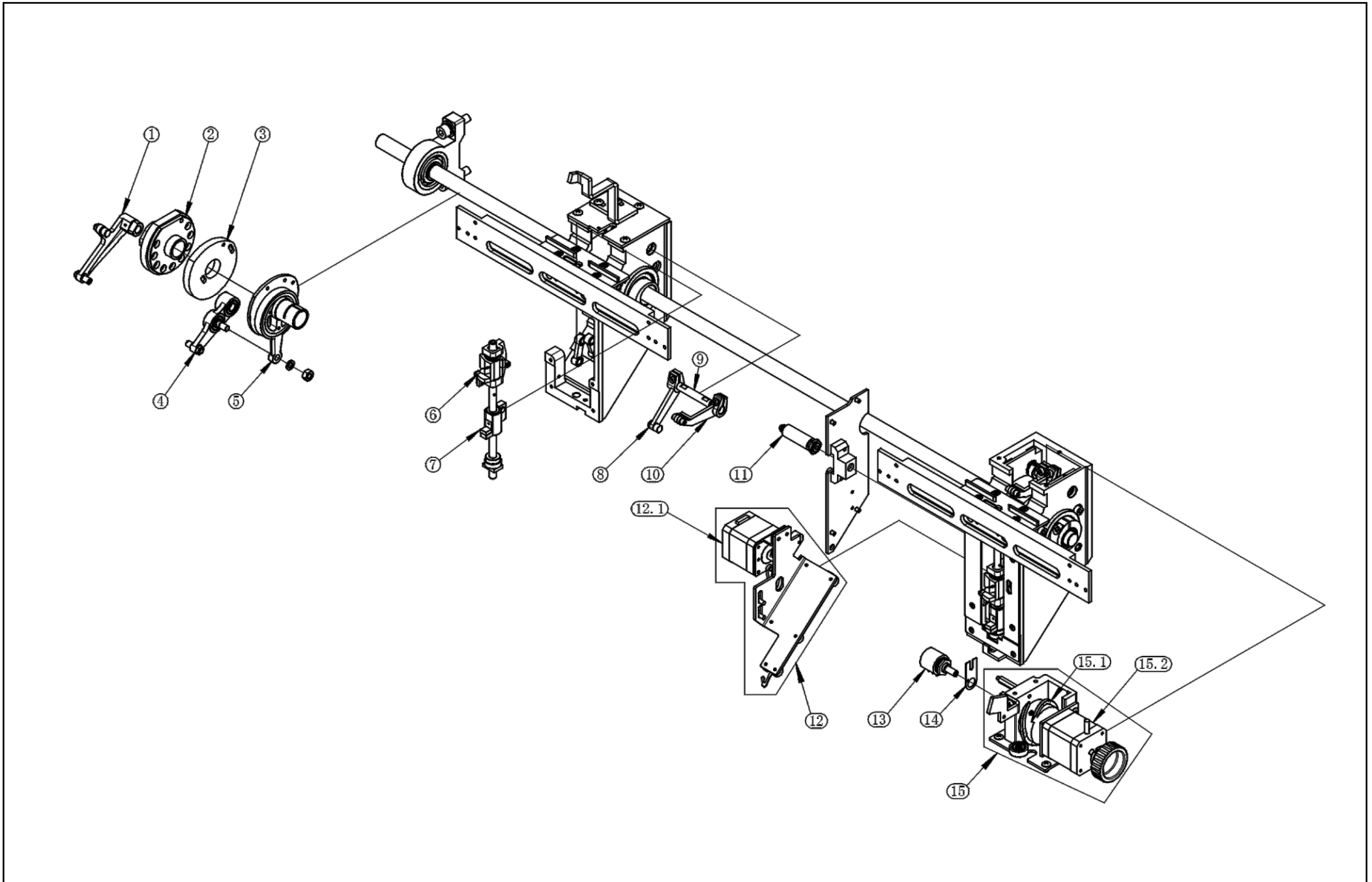

03.HeadColor Change-MT-2T

No.	Serial No.	Part name	Remark
1	01212262	Press Foot Rod - Double Cam	
2	01212271	Press Foot Cam + AL Ring + Al Base-15 shaft	
3	01212404DY	Thread-taking-up Nylon Cam-Single Cam Double Drive-15 shaft	
4	01212161	Three-eye connecting rod assembly – high speed	
5	01212464	Large connecting rod assembly-single cam double drive-15 shafts	
6	01212073	Reciprocator-High speed-Solenoid-Double Cam	
7	01212260DX	Press Foot Driver Set-DX	
8	01212163DX	Thread take-up connecting rod assembly A	
9	01212307DX	Take up lever Pin	

No.	Serial No.	Part name	Remark
10	01212165DX	Thread take-up connecting rod assembly B	
11	80320201	Solenoid	
12	01431281	Thread hooking device-step-wide machine head	
12.1	42BYGH4408-12	Catching motor	
13	03150833	Multi-turn potentiometer-DT	
14	03040510	potentiometer support plate	
15	01293862VA	Stepper42-color changing assembly-high speed	
15.1	01293813	changing color cam-double rail-steel	
15.2	17H2059-12-6B	color change motor	

04.Needle Bar Case-MT-2T

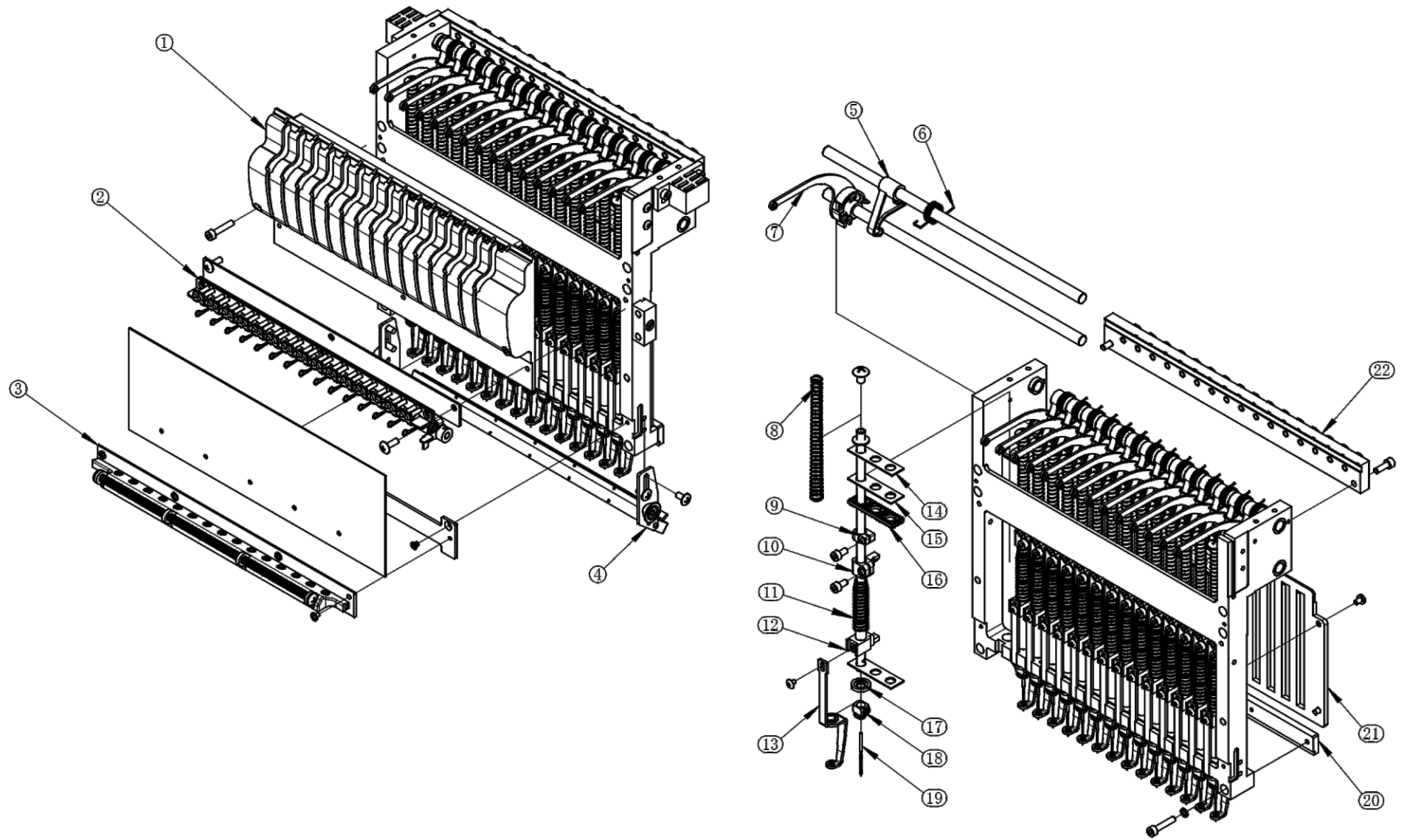

04.Needle Bar Case-MT-2T

No.	Serial No.	Part name	Remark
1	72011215-RH	15 needles upper plate-customized dark grey	15
1	72011212-RH	15 needles upper plate-customized dark grey	12
2	03082592	Middle thread guide module-15	15
2	03082591	Middle thread guide module-12	12
3	03096015	Lower thread guide module-LED-15	15
3	03096012	Lower thread guide module-LED-15	12
4	03086193	Front thread clamp module-15	15
4	03086192	Front thread clamp module-12	12
5	01213312	Positioning block of take-up lever	
6	03081503	Fixed block torsional spring	
7	01213371	Take-up lever assembly	
8	03080102	Needle bar spring-P	
9	01222105	Upper end stopper clamp	
10	01222106	Needle bar connecting pin	
11	03080108	Presser foot spring-P	

No.	Serial No.	Part name	Remark
12	03080104AB	Sleeve-coffee color-with screw	
13	4006260200	Press foot and cushion-high speed	
14	01221602	3 pore cushion-1	
15	01221606	3 pore felt cushion	
16	01221605	3 pore rubber cushion	
17	01222110	Cushion	
18	01222194	Normal clamp with screw	
19	80621111	Needle-DBXK5-11	
20	01213116	Lower guide rail -high speed-15	15
20	01213115	Lower guide rail -high speed-12	12
21	03081311	Needle bar guide plate-15	15
21	03081301	Needle bar guide plate-12	12
22	03081215	15 needle change color plate module	15
22	03081282	12 needle change color plate module	12

05.Trim and Driving-MT-2T

No.	Serial No.	Part name	Remark
1	RCM-ZPS1V12	Sensor-Zero Position-MT	
2	02311181	bearing base	
3	80025152	Synchronous belt 5M-20-1690	
4	3011200160	Eccentric wheel Module-MT-up and down movement	
5	3011200192VA	Timing Pulley-Up and down shaft-MT-M	

No.	Serial No.	Part name	Remark
6	01400660	Trimming box bearing assembly-SY	
7	3011200193VA	Timing Pulley-Main shaft-MT-M	
8	70SF3A90-330-1000Z-02	Main motor	
9	80333602	Cylinder-shaped proximity switch NPN	
10	57BYGH80D10-15	Trimming motor	

06.Y-Axis Driving-MT-2T

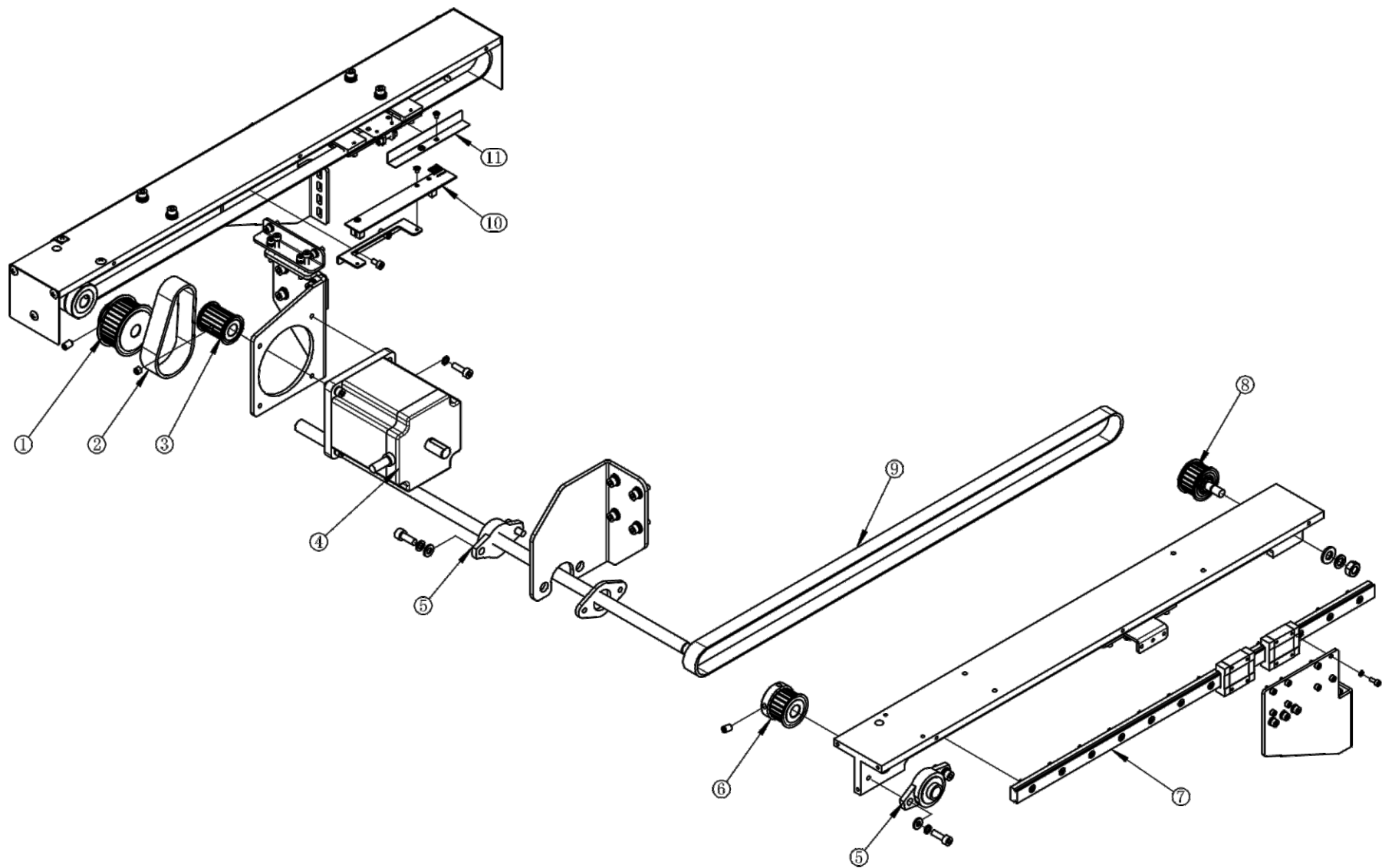

06.Y-Axis Driving-MT-2T

No.	Serial No.	Part name	Remark
1	3011212095	Synchronous pulley-transition-MT-Y	
2	80025151	Synchronous belt 5M-20-235	
3	3011200193VA	Timing Pulley-Main shaft-MT-M	
4	86BYG350	Y-Axis motor	
5	80039010	Insert bearing UFL001-D12	

No.	Serial No.	Part name	Remark
6	3011212092	Synchronous pulley-driving-MT-Y	
7	8001510480	Linear guide rail-BRH15-480	
8	3011212080	Driven wheel module-MT-Y	
9	RCM-SW2V13	Sensor-Limit-XY	
10	3011212097	Synchronous belt-MT-Y	

07.X-Axis Driving-MT-2T

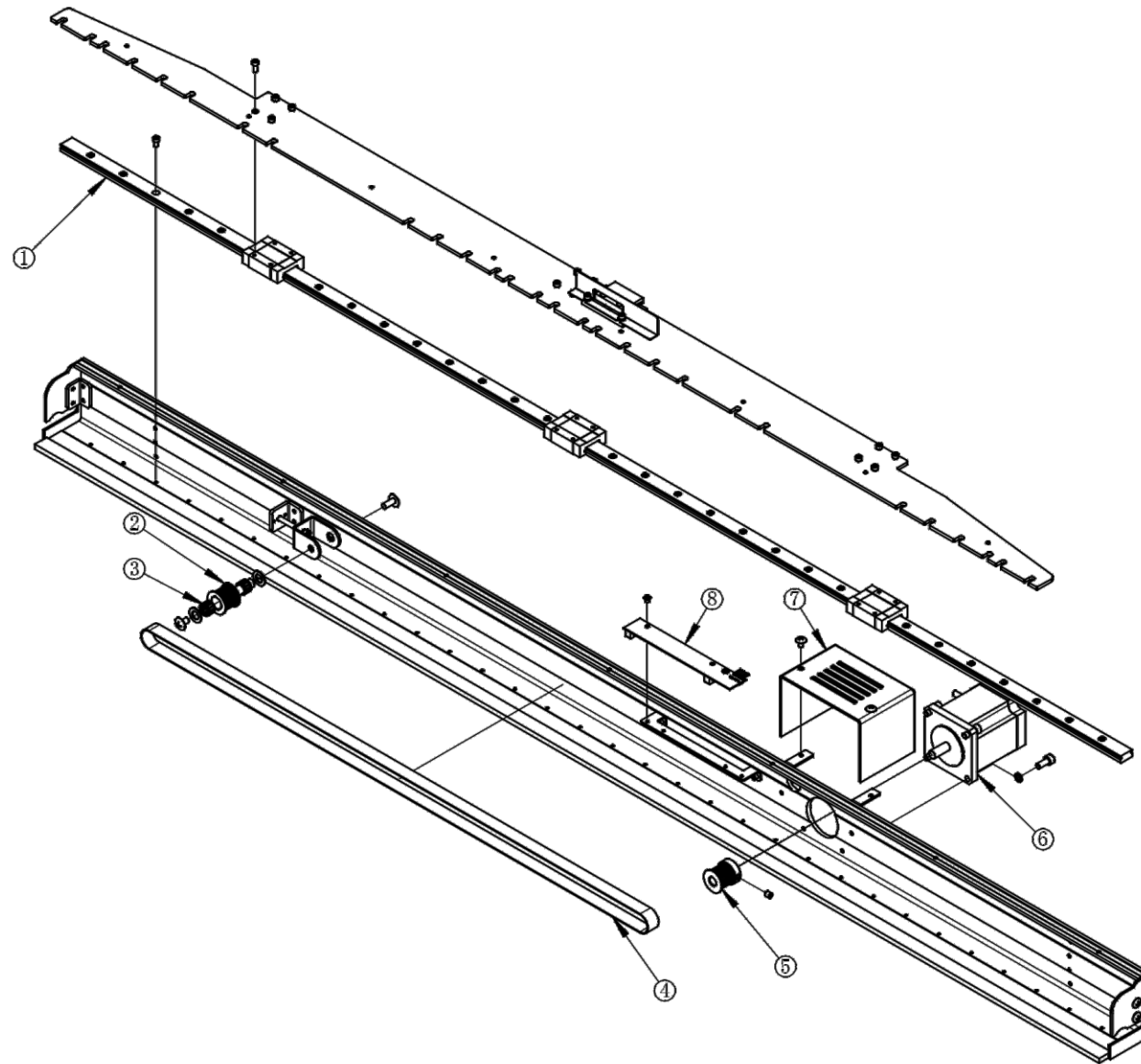

07.X-Axis Driving-MT-2T

No.	Serial No.	Part name	Remark
1	8001511300	Guide rail BRH15-1300	
2	80023602	Pulley 20-3M-15-12	
3	80030831	Needle Roller Bearing 8-12-8	
4	3011211297	Synchronous belt-X-MT-2T	

No.	Serial No.	Part name	Remark
5	80023601	Pulley 20-3M-16-8	
6	60BYG350	X-axis motor	
7	03100121AB	X direction motor cover	
8	RCM-SW2V13	Sensor-Limit XY	

08.Thread Support & Stand-MT-2T

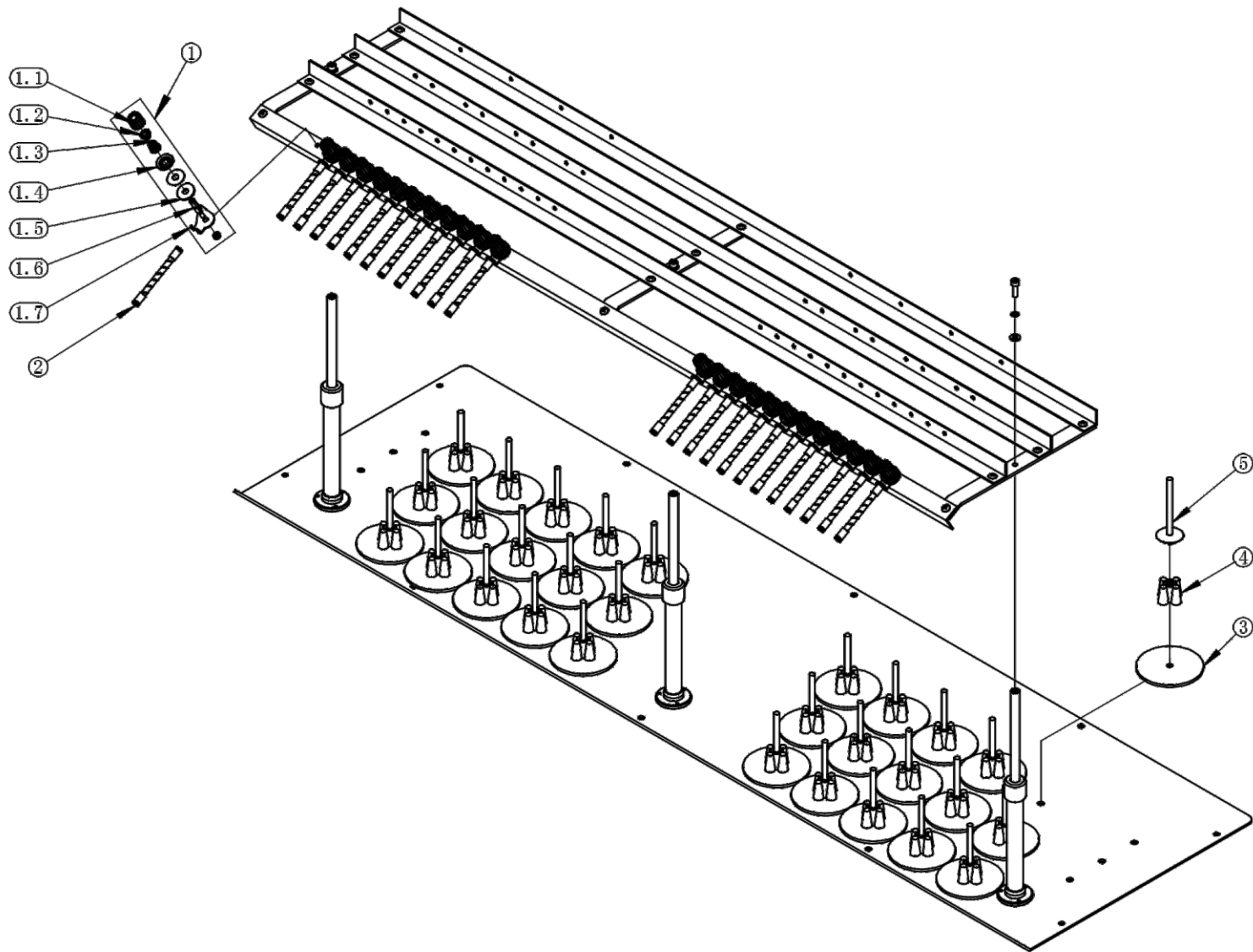

08.Thread Support & Stand-MT-2T

No.	Serial No.	Part name	Remark
1	03144260	Adjusting knob assembly-RCM-gray	
1.1	03144207	Wire clamping knob - wheel	
1.2	03044155	Locking washer	
1.3	03144209	spring-wheel	
1.4	03144202	press plate-wheel	
1.5	80211104	Felt gasket	

No.	Serial No.	Part name	Remark
1.6	03144208	Wiring nail - wheel	
1.7	03141001	Threading base-wheel	
2	03044360	Threading pipe-spiral	
3	80211009	foam rubber cushion	
4	80211008	Thread cone cushion	
5	80211007	Thread cone pole	

09.Thread Tension Base-MT-2T

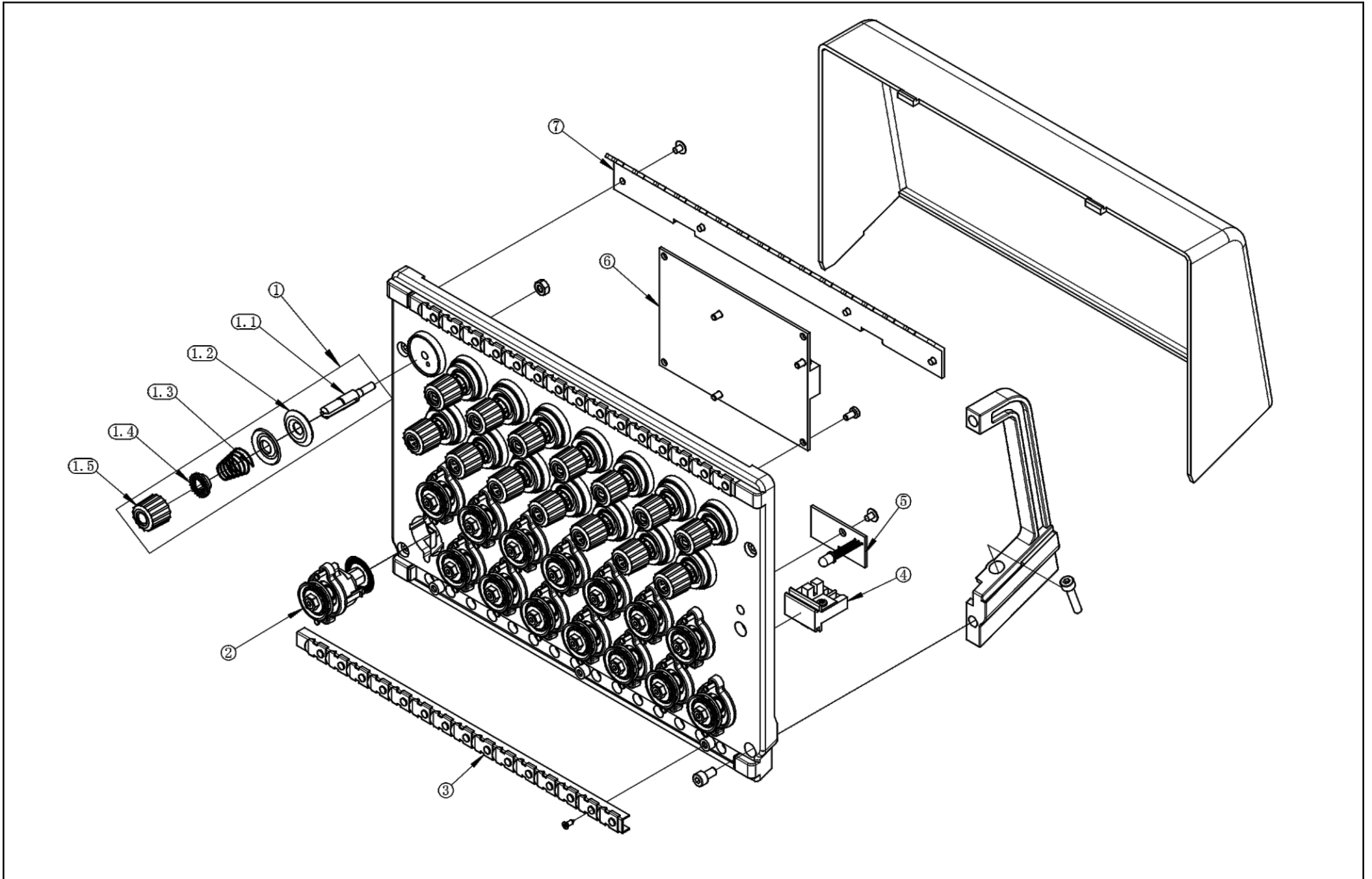

09.Thread Tension Base-MT-2T

No.	Serial No.	Part name	Remark
1	03144254	Adjusting knob assembly – yarn trapper	
1.1	03144208	Thread clamping nail - wheel	
1.2	03144202	press plate- wheel	
1.3	03144224	spring	
1.4	03144226	Lock washer - wheel	
1.5	03144207	Thread clamping knob - wheel	

No.	Serial No.	Part name	Remark
2	03144252	thread course wheel module-bearing	
3	03144353	Thread course board-15	
4	RCM-DJ1V12A	Sensor board - thread breaking detection	
5	03150802MT	head indicator board	
6	HEAD2V22B	Head board - wheel - solenoid	
7	03144310	Thread guide support plate – 15 needles	

10. Electrical Part-MT-2T

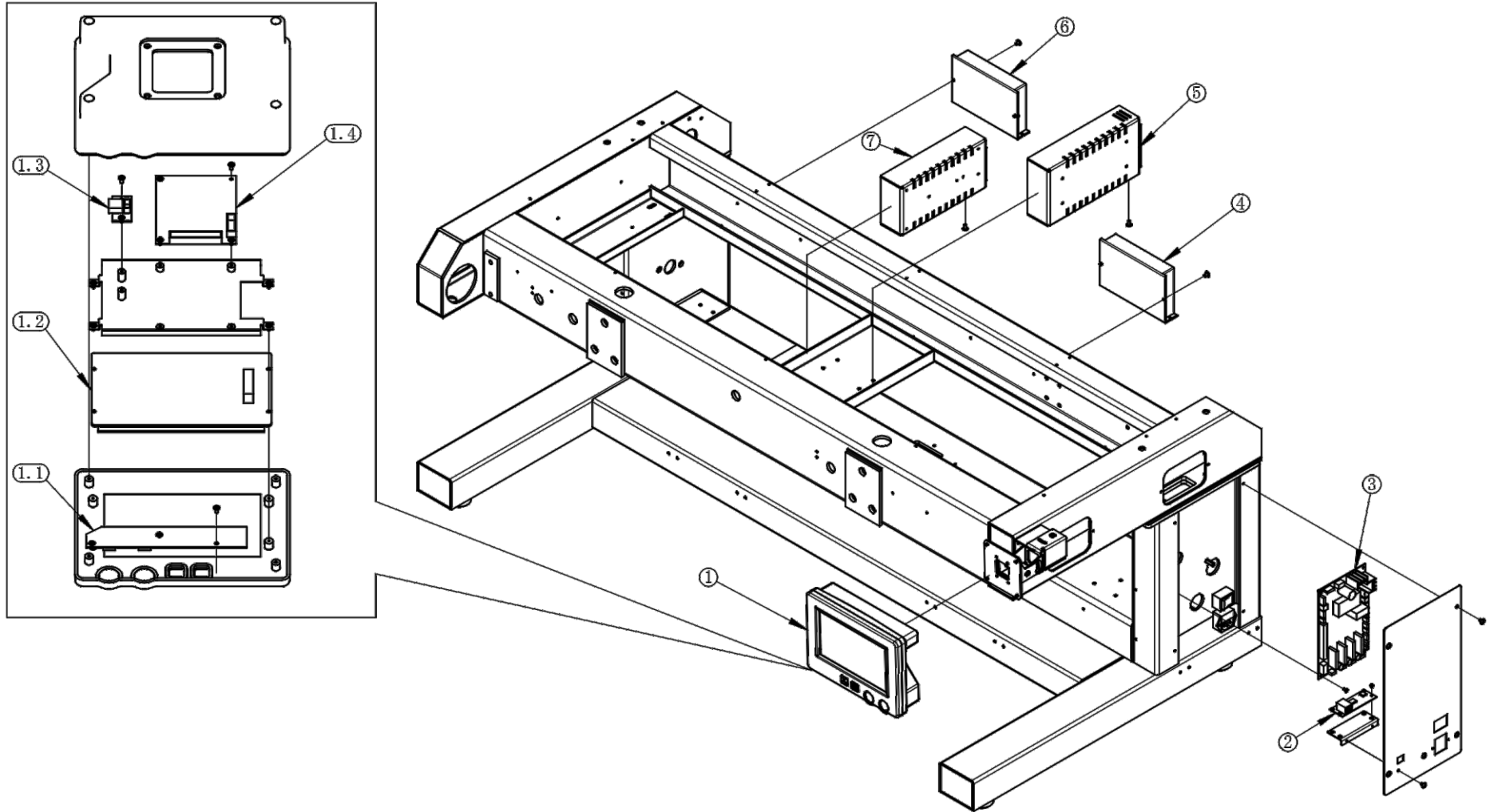

10. Electrical Part-MT-2T

No.	Serial No.	Part name	Remark
1	03151561MT	control panel module-MT	
1.1	RCM-KEY4V21	Key board panel	
1.2	B7084TZ	Touch screen panel	
1.3	USB1V12	USB port board	
1.4	RMBD2V13001	Main board	
2	RCM-ENET1V12	Internet port board	

No.	Serial No.	Part name	Remark
3	RCM-SMR2V33-C	Multi-function board	
4	RCM-3PS-48	Driver (XY motor)	
5	PDF-600-36	Power switch (main motor)	
6	RCM-MT-PMSM2V12	Driver (main motor)	
7	GKF-200-48	Power switch (X, Y motor)	

11.Frame-MT-2T

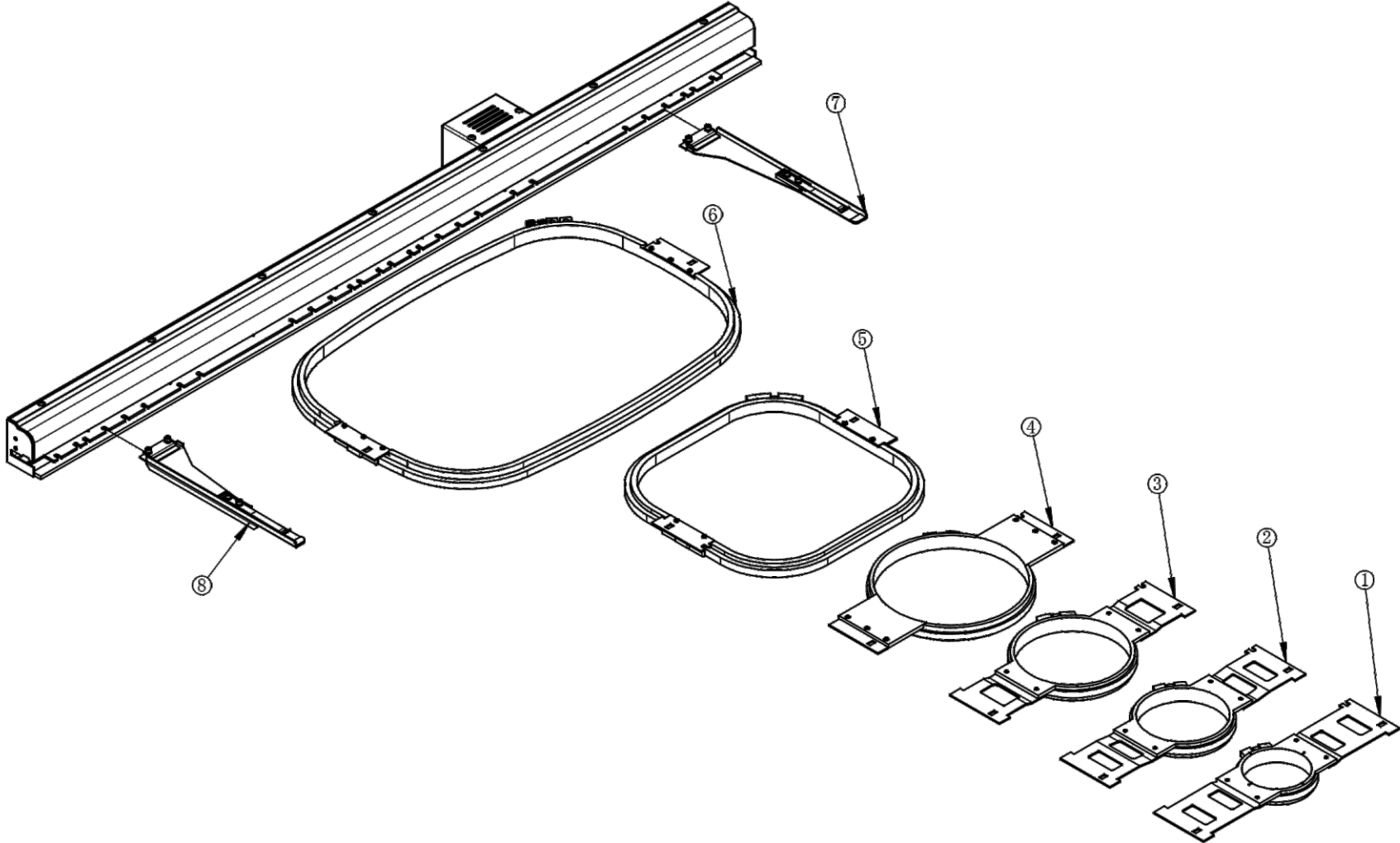

11.Frame-MT-2T

No.	Serial No.	Part name	Remark
1	03171181	Round frame-90	
2	03171681	Round frame-120	
3	03172181	Round frame-150	
4	03172681	Round frame-200	

No.	Serial No.	Part name	Remark
5	03173181	Square frame-290x290	
6	03173661	Square frame-540x360	
7	03100291	frame bracket module-R	
8	03100292	frame support module-L	

12.Cap Driver-MT-2T

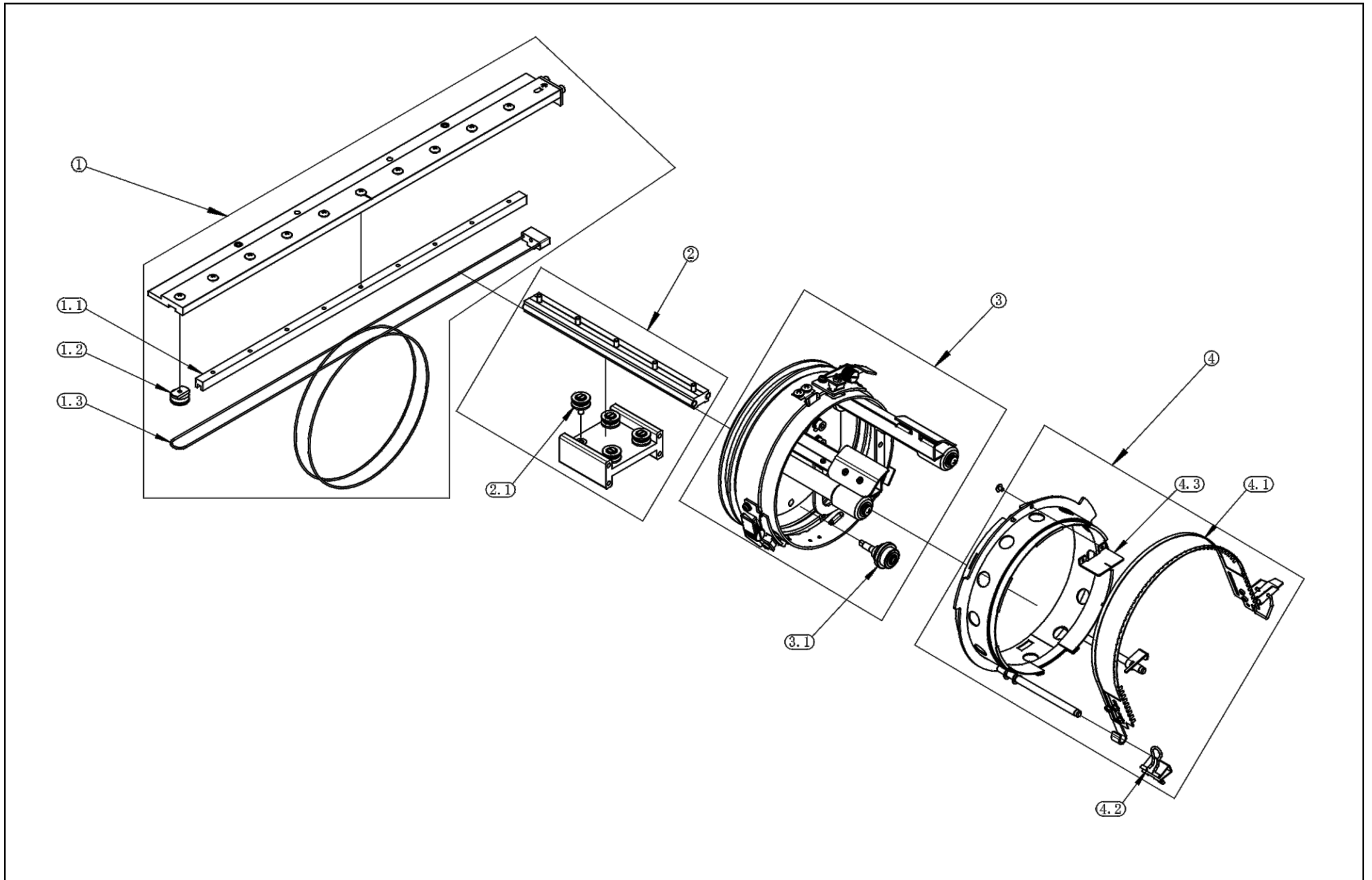

12.Cap Driver-MT-2T

No.	Serial No.	Part name	Remark
1	02815042	Cap drive junction plate kit-P-MT	
1.1	02815002	cap drive strip	
1.2	02815008	steel wire wheel	
1.3	02815052	Cap steel wire assembly-P-MT	
2	02815039	Linear guide rail module RCM-220	
2.1	02815032	Guide rail roller-G15	

No.	Serial No.	Part name	Remark
3	02815082	Cap rack–big shuttle box	
3.1	02810161	eccentric wheel assembly	
4	02811080	Cap ring assembly-360	
4.1	02811082	cap strapping rod assembly	
4.2	02811055	clamp - cap ring	
4.3	02811006	positioning block	

13. Table-MT-2T

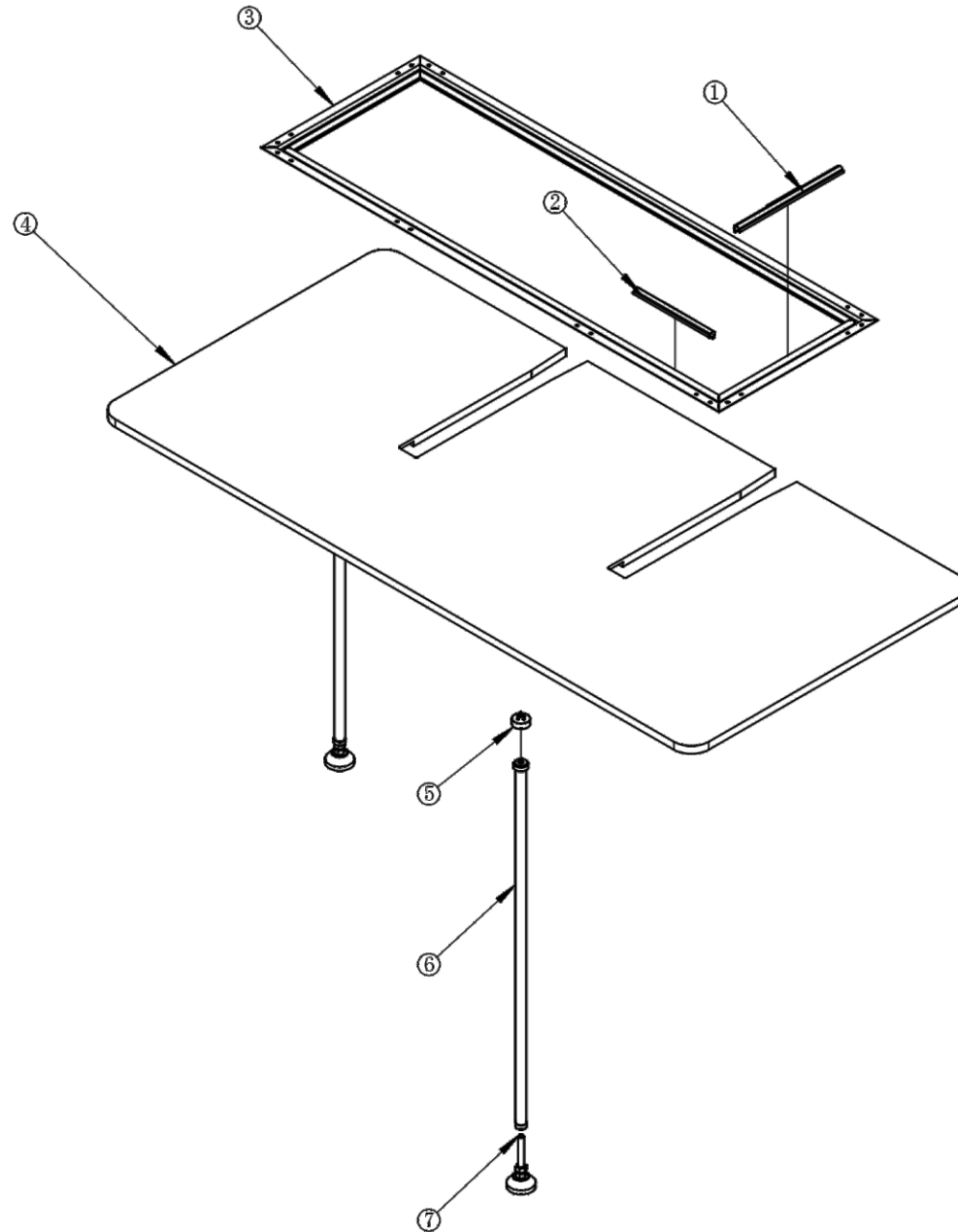

13. Table-MT-2T

No.	Serial No.	Part name	Remark
1	01505101	Feed collet-300	
2	01505102	Feed collet-220	
3	3011311060	Flat sash frame-MT-2T-4814	
4	3011311002	Flat table-MT-2T	

No.	Serial No.	Part name	Remark
5	03010313	table suport magnet base	
6	03010365	table support set-P-MT	
7	80270831	Support Feet-Nylon-Φ50-M12*50	



Copyright © RiCOMA (Shenzhen) Co., Ltd. All rights reserved.